

GRADE INFORMATION

CERAMIC

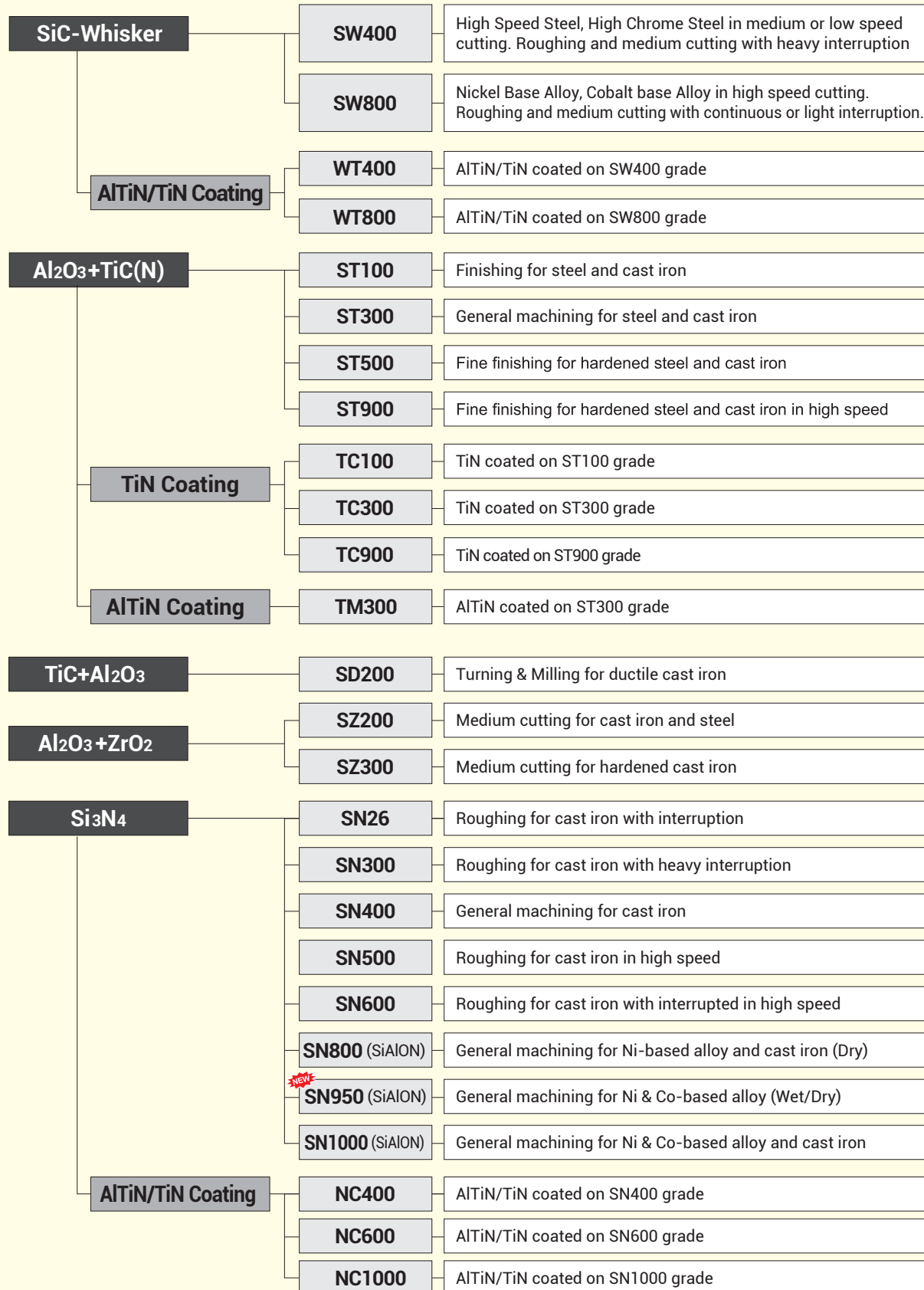

CERMET

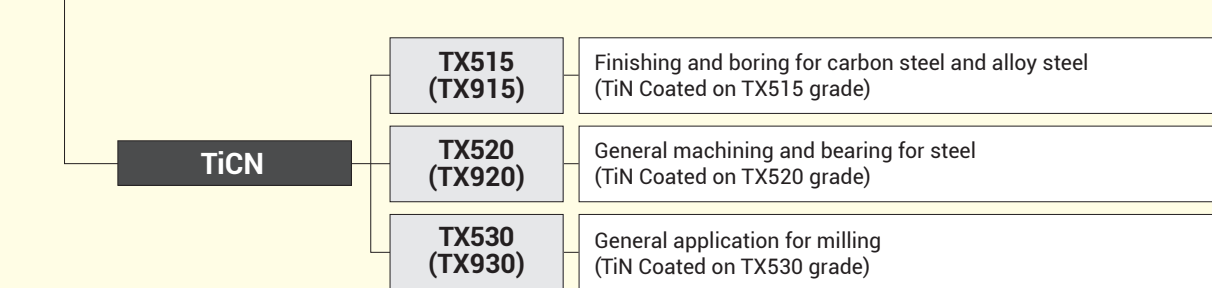

CARBIDE

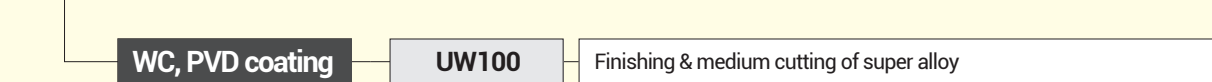

PCBN/PCD

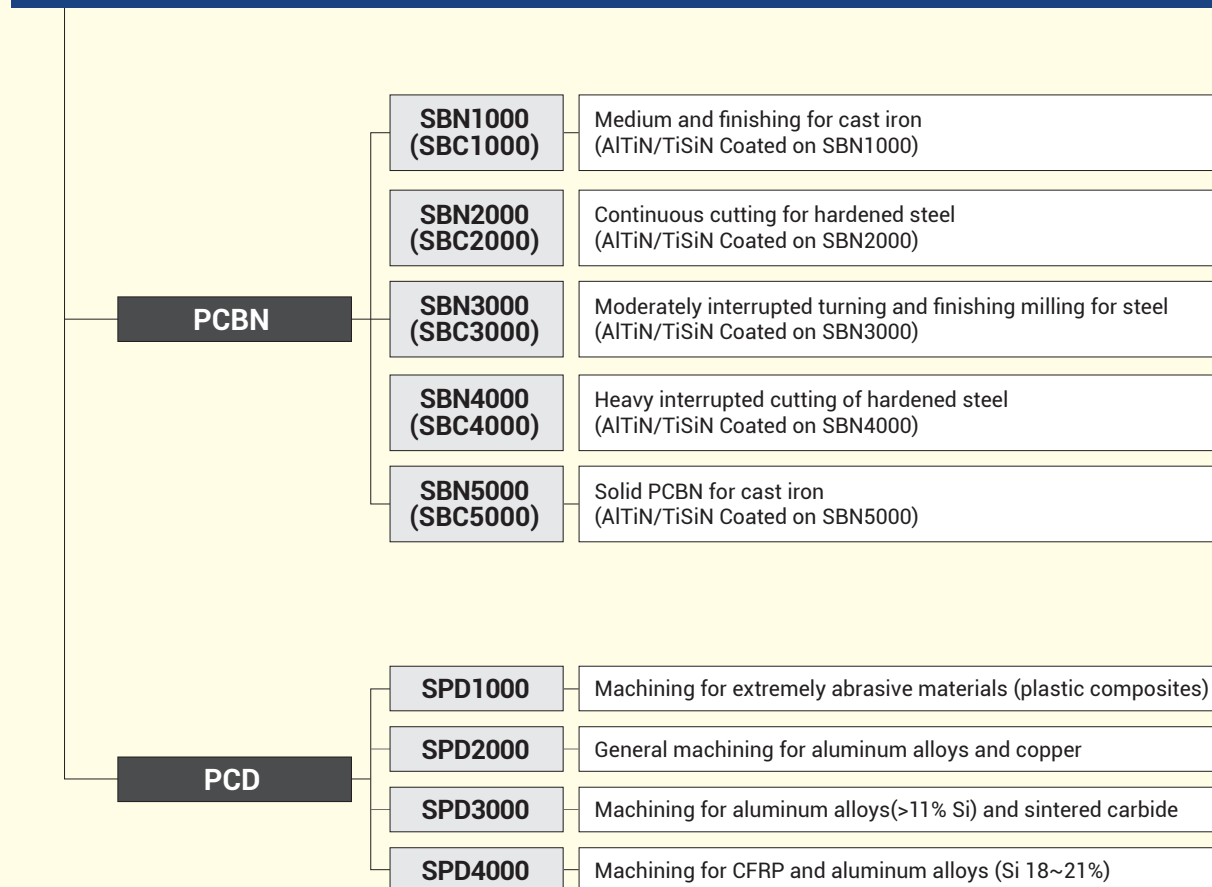

GRADE INFORMATION

Application Range

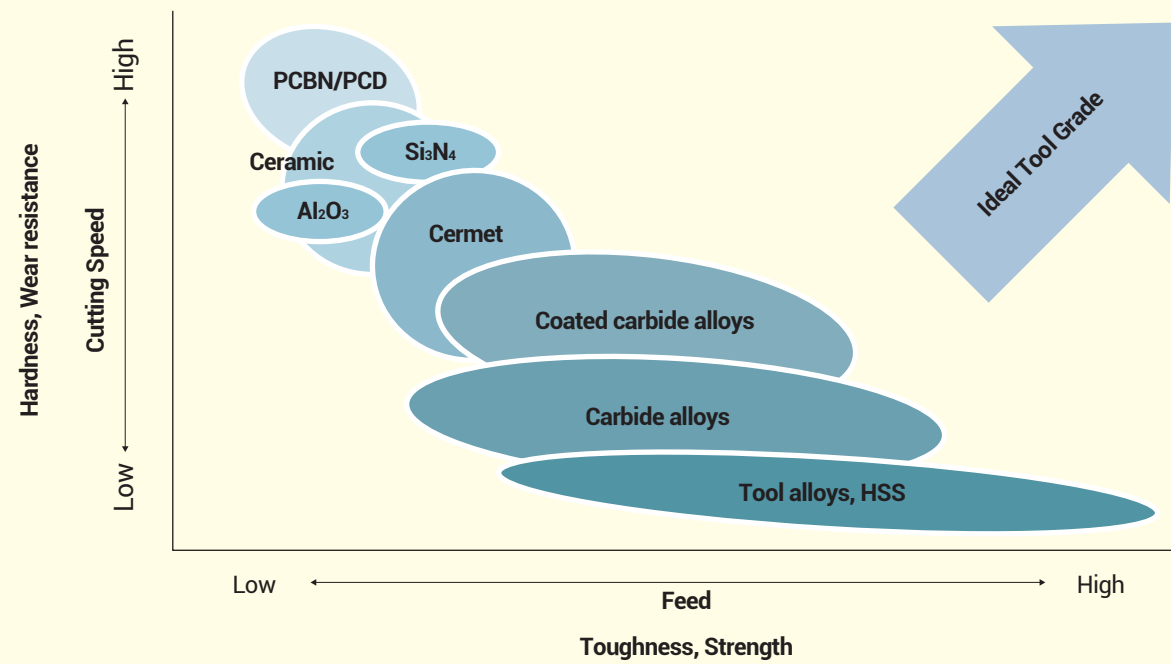

Mechanical Properties

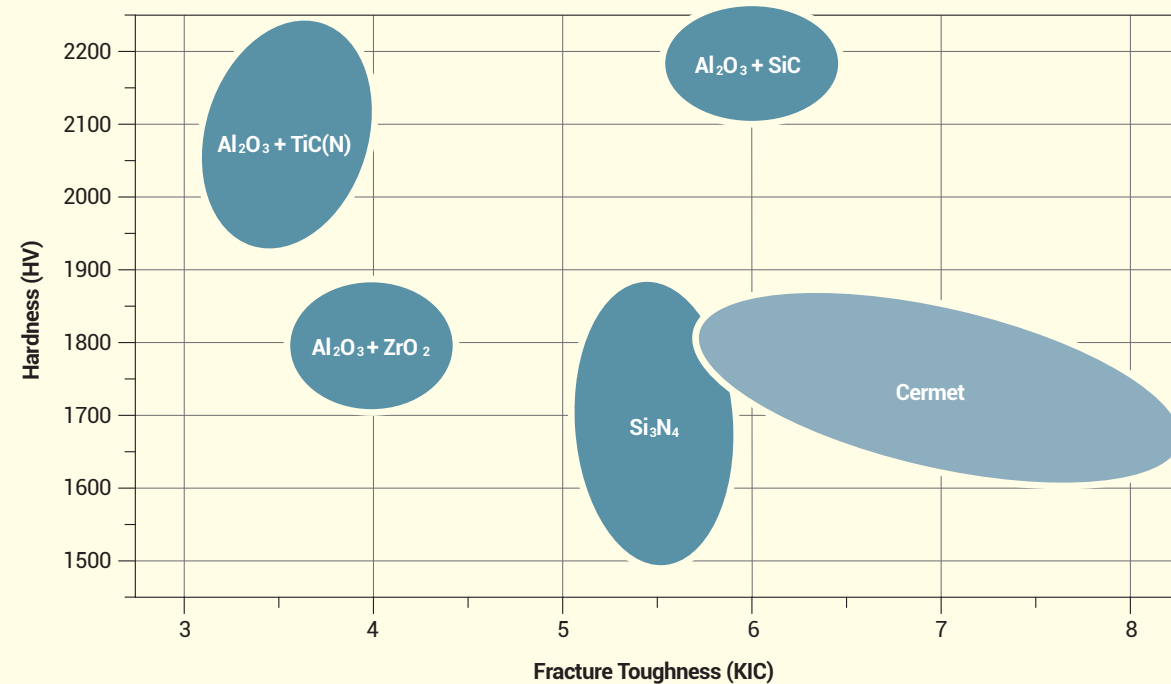

CERAMIC

Union Ceramics take pride in its outstanding wear resistance and thermal shock resistance with high speed cutting. Pure raw materials give stability and fine microstructure to the products. Through proper or optimum process, shaped bodies are completely condensed so that finished goods are strong and resistant against fracture and wear.

- Improved work efficiency by increasing cutting speed on extremely higher than carbide inserts.
- Longer tool life through excellent wear resistance
- Precise cutting and superior surface roughness

Whisker	SW400	Excellent flank & Notch wear in high speed cutting Al ₂ O ₃ +SiC	High Speed Steel, High Chrome Steel in medium or low speed cutting Roughing and medium cutting with heavy interruption	Tougher
	SW800	Excellent flank & Notch wear in high speed cutting Al ₂ O ₃ +SiC	Nickel Base Alloy, Cobalt Base Alloy in high speed cutting Roughing and finishing with continuous or light interruption	Harder
	WT400	Improved notch wear resistance & tool life AlTiN+TiN multi coating on SW400	High Speed Steel & High Chrome Steel Roughing and medium cutting with heavy interruption	
Al ₂ O ₃ Series	WT800	Improved notch wear resistance & tool life AlTiN+TiN multi coating on SW800	Nickel Base Alloy & Cobalt Base Alloys Roughing and finishing with light interruption	Harder
	ST100	Tougher than ST300 High thermal shock resistance Al ₂ O ₃ +TiC	Universal grade for machining cast iron and steel	Tougher
	ST300	Excellent wear resistance Al ₂ O ₃ +TiCN	A basic choice for machining steel and cast iron	Harder
	ST500	Alternative to PCBN, Fine microstructure Al ₂ O ₃ +TiCN	Fine finishing for hardened steel and cast iron	
	ST900	Excellent wear and thermal shock resistance Al ₂ O ₃ +TiCN	Fine finishing for hardened steel and cast iron in high speed	
	TC100	Good wear resistance TiN coating on ST100	Finishing for steel and cast iron	
	TC300	Excellent wear resistance TiN coating on ST300	Finishing for steel and cast iron	
	TC900	Excellent wear resistance TiN coating on ST900	Finishing for hardened steel and cast iron	
	TM300	Excellent wear resistance & thermal shock resistance AlTiN coating on ST300	Finishing for steel and cast iron	Harder
	SD200	High thermal shock resistance, Usable with coolant TiC+Al ₂ O ₃	Machining ductile cast iron Finishing for ductile cast iron and hard materials	Finishing for ductile cast iron
ZrO ₂ Series	SZ200	Toughened by zirconia, High chemical stability Al ₂ O ₃ +ZrO ₂	Finishing, semi-finishing of cast iron and steel	Tougher
	SZ300	Harder alternative to SZ200 Al ₂ O ₃ +ZrO ₂	Finishing, semi-finishing of cast iron and steel	Harder
Si ₃ N ₄ Series	SN26	Good toughness and thermal shock resistance Well balanced wear resistance and toughness Si ₃ N ₄	First choice for roughing with interrupted cuts Roll turning and milling of cast iron and steel	Roughing in lower speed
	SN300	Tougher alternative to SN400 Good toughness and thermal shock resistance Si ₃ N ₄	Roughing and high speed cutting with interruption	Tougher
	SN400	Excellent wear resistance in high speed cutting Si ₃ N ₄	Frist choice for roughing of cast iron High speed machining with interrupted cuts	Harder
	SN500	Harder alternative to SN400 Improved wear resistance at hugh speed cutting Si ₃ N ₄	High speed roughing for cast iron	
	SN600	Excellent wear resistance in interrupted cutting Si ₃ N ₄	Roughing for cast iron with interruption and high speed	Harder
	NC400	Excellent wear resistance & thermal shock resistance AlTiN+TiN multi coating on SN400	Cast iron in roughing and semi-finishing cutting	Tougher
SiAlON Series	NC600	Excellent wear resistance & thermal shock resistance AlTiN+TiN multi coating on SN600	Cast iron in roughing and semi-finishing cutting	Harder
	SN800	Excellent wear resistance SiAlON	In Dry cutting condition, great performance against notch wear Machining for steel and HRSA materials in high speed	Tougher
	SN950	Excellent strength and wear resistance SiAlON	Great performance for roughing & finishing A basic choice for machining HRSA materials	Harder
	SN1000	Excellent thermal shock resistance and wear resistance SiAlON	Medium or low speed cutting of HRSA materials and cast iron Roughing and medium cutting with heavy interruption	
	NC1000	Excellent thermal shock resistance and wear resistance AlTiN+TiN multi coating on SN1000	Medium or low speed cutting of HRSA materials and cast iron Roughing and medium cutting with heavy interruption	Harder

GRADE INFORMATION

Physical Properties

Grade	Coated	Composition	Color	Density (g/cm ³)	Hardness (H _v)	Toughness (MPa·m ^{1/2})
SW400		Al ₂ O ₃ + SiC	Green	3.8	2,100	6.0
	WT400	(AlTiN+TiN)	Gold			
SW800		Al ₂ O ₃ + SiC	Green	3.7	2,100	6.5
	WT800	(AlTiN+TiN)	Gold			
ST100		Al ₂ O ₃ + TiC	Black	4.2	2,100	4.5
	TC100	(TiN)	Gold			
ST300		Al ₂ O ₃ + TiCN	Black	4.4	2,150	4.0
	TC300	(TiN)	Gold			
	TM300	(AlTiN)	Black			
ST500		Al ₂ O ₃ + TiCN	Black	4.3	2,200	4.0
ST900		Al ₂ O ₃ + TiCN	Black	4.3	2,200	4.5
	TC900	(TiN)	Gold			
SD200		TiC + Al ₂ O ₃	Black	4.6	2,250	5.0
SZ200		Al ₂ O ₃ + ZrO ₂	White	4.1	1,800	4.5
SZ300		Al ₂ O ₃ + ZrO ₂	Pink	4.1	1,850	4.0
SN26		Si ₃ N ₄	Black	3.3	1,600	6.0
SN300		Si ₃ N ₄	Gray	3.2	1,600	6.5
SN400		Si ₃ N ₄	Gray	3.2	1,650	6.5
	NC400	(AlTiN+TiN)	Gold			
SN500		Si ₃ N ₄	Gray	3.2	1,650	6.5
SN600		Si ₃ N ₄	Black	3.2	1,700	7.0
	NC600	(AlTiN+TiN)	Gold			
SN800		Si ₃ N ₄ + Al ₂ O ₃	Black	3.2	1,900	6.5
SN950		Si ₃ N ₄ + Al ₂ O ₃	Black	3.3	1,750	7.5
SN1000		Si ₃ N ₄ + Al ₂ O ₃	Black	3.3	1,800	7.0
	NC1000	(AlTiN+TiN)	Gold			

Choice of Ceramic Grade for Workpiece

Workpiece		ST100/ST300 TC100/TC300 TM300	ST500 ST900 TC900	SD200	SZ200 SZ300	SN26 SN300/SN400 SN500/SN600 NC400/NC600	SN800	SN950 SN1000 NC1000	SW400 WT400	SW800 WT800
Cast Iron	Gray cast iron	◎	○	○	◎	◎	◎	○		
	Chilled cast iron	○	○		○	○	◎	○		
	Ductile cast iron	○		◎		○	○	○		
Steel	Mild steel	○			○					
	Carbon steel	○			○					
	Alloy steel	◎	○		○		○	○	○	○
	Forged steel	○	◎							
	Heat treated steel	○	◎							
	High speed steel	○	◎						◎	○
	High manganese steel	○	○			○	○	○	◎	○
	Stainless steel									
	Heat resistant super alloy						○	◎	○	◎

◎ : Excellent ○ : Good

Choice of Ceramic Grade for Workpiece

Application	Grade	Workpiece	Machining Type	Speed (V) (m/min)	Feed (f) (mm/rev)	Depth (DOC) (mm)
Turning	ST100 ST300 ST500 ST900 TC100 TC300 TC900 TM300	Gray Cast Iron	Gray Cast Iron (FC)	Rough	150 ~ 800	0.2 ~ 0.5
			Malleable (FCMB)	Finish	200 ~ 1,200	0.3 ~ 0.5
		Chilled Cast Iron	Rough	30 ~ 100	0.1 ~ 0.2	0.5 ~ 1.5
	Steel	Carbon Steel Alloy Steel Bearing Steel	Rough	150 ~ 400	0.2 ~ 0.5	2 ~ 5
			Finish	200 ~ 800	0.05 ~ 0.2	0.1 ~ 0.5
		Hard Steel (HRC 45≥)	Rough	20 ~ 100	0.1 ~ 0.2	0.5 ~ 1.5
	Finish	40 ~ 200	0.05 ~ 0.5	0.1 ~ 0.5		
	SD200	Ductile Cast Iron Nodular Cast Iron	Rough	100 ~ 400	0.1 ~ 0.2	1 ~ 2
	Finish	200 ~ 800	0.05 ~ 0.25	0.1 ~ 0.5		
	SZ200 SZ300	Gray Cast Iron (FC) Steel (HRC 45±)	Rough	200 ~ 700	0.2 ~ 0.4	2 ~ 5
	Finish	300 ~ 1,200	0.05 ~ 0.3	0.1 ~ 0.5		
	Milling	SN26 SN300 SN400 SN500 SN600 NC400 NC600	Gray Cast Iron	Gray Cast Iron (FC)	Rough	150 ~ 1,100
Malleable (FCMB)				Finish	250 ~ 1,200	0.15 ~ 0.4
Chilled Cast Iron			Rough	20 ~ 100	1.0 ~ 2.0	< 5
			Finish	60 ~ 200	0.5 ~ 1.0	< 1
			SN800 SN950 SN1000	Ni-Based Alloy Non-Ferrous Metal Inconel	Rough	150 ~ 250
Finish		150 ~ 450	0.1 ~ 0.2	< 1		
SW400 SW800 WT400 WT800		High temperature alloys Inconel Stellite	Rough	180 ~ 360	0.1 ~ 0.25	1 ~ 3
			Finish	180 ~ 450	0.1 ~ 0.30	0.5 ~ 2.0
		Gray Cast Iron (FC)	Rough	100 ~ 1,200	0.3 ~ 0.5	< 5
			Finish	150 ~ 1,500	0.3 ~ 0.7	< 3
	Ductile Cast Iron Alloy Steel		Rough	90 ~ 500	0.1 ~ 0.3	< 5
Finish		100 ~ 700	0.1 ~ 0.4	< 3		
SN800 SN1000	High temperature alloys Inconel Stellite	Finish	700 ~ 1,000	0.05 ~ 0.15 / tooth	0.5 ~ 2.5	
SW400 SW800 WT400 WT800	High temperature alloys Inconel	Rough	150 ~ 400	0.05 ~ 0.1 / tooth	1 ~ 3	

GRADE INFORMATION

CERMET

A matrix of TiCN with carbide as a metal binder, Union Cermet's are tougher than ceramics and harder than tungsten carbides. It shows greater wear resistance than carbide and its cutting speed is also much higher than carbide. Cermet inserts give excellent surface finish and high-speed machining.

- Four different grades for different workpiece and cutting condition.
- Ideal for high-speed finishing and milling of mild steel, carbon steel and alloy steel.
- Excellent performance in turning, grooving, boring, bearing and milling.

	TX515	Wear resistance and high mechanical strength TiCN	Finishing and boring for carbon steel and alloy steel	Harder ↑ ↓ Tougher
	TX915	TiN coating		
	TX520	Excellent thermal conductivity and wear resistance TiCN	The first choice for machining steel Turning, grooving, boring and bearing for steel	
	TX920	TiN coating		
	TX530	The toughest cermet grade TiCN	Wide range of milling for steel materials	
	TX930	TiN coating		

Physical Properties

Grade	Composition	Color	Density (g/cm ³)	Hardness (HRA)	Toughness (MPa·m ^{1/2})	Thermal Conductivity (cal/cm. sec. °C)
TX515	TiCN	Silver	6.48	93.00	7.50	0.08
TX520	TiCN	Silver	6.53	92.50	8.00	0.09
TX530	TiCN	Silver	6.35	91.00	8.40	0.09
TX915	TX515+TiN PVD	Gold	6.48	98.00	7.50	-
TX920	TX520+TiN PVD	Gold	6.53	97.50	8.00	-
TX930	TX530+TiN PVD	Gold	6.35	96.00	8.40	-

Choice of Ceramic Grade for Workpiece

	TX515/TX915	TX520/TX920	TX530/TX930
MILD STEEL	◎	◎	○
CARBON STEEL	◎	◎	◎
ALLOY STEEL	○	○	○
FORGED STEEL			
HEAT TREATED STEEL			
HEAT RESISTANT STEEL	◎	◎	◎

◎ : Excellent ○ : Good

Choice of Ceramic Grade for Workpiece

Application	Grade	Workpiece	Machining Type	Speed (V) (m/min)	Feed (f) (mm/rev)	Depth (DOC) (mm)
Turning	TX515/TX915	Mild Steel, Carbon Steel, Alloy Steel	Finishing Medium	100 ~ 500	0.03 ~ 0.3	0.1 ~ 2.0
	TX520/TX920	Bearing Steel, General Steel	Finishing Medium	100 ~ 400	0.03 ~ 0.3	0.1 ~ 2.0
Milling	TX530/TX930	Mild Steel, Carbon Steel, Alloy Steel	Medium Roughing	100 ~ 400 100 ~ 500	0.1 ~ 0.3 0.1 ~ 0.5	< 5 < 3

Choice of Chipbreaker

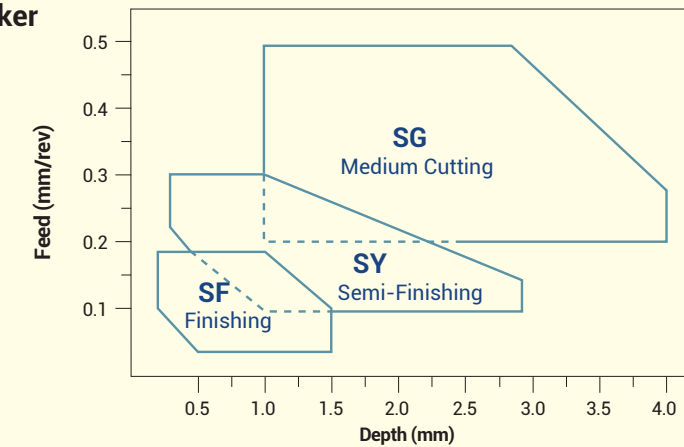

Chipbreaker Type	Shape	Machining Type	Characteristics
SF		Finishing	Sharp and narrow C/B Optimum for D=0.10~1.50, f=0.05~0.20 Specialized for shaft machining
SY		Semi-finishing	General performing C/B Optimum for D=0.30~2.50, f=0.10~0.30 Low carbon steel, pipe (STKM) machining
SG		Medium cutting	Wider C/B design Optimum for D=1.00~5.00, f=0.20~0.50 Low carbon steel

CARBIDE

Grade Information

Grade	Microstructure	Application Range		
UW100		Finishing & Medium cutting of super alloys(HRSA, Ti-Alloy etc) High temperature oxidation resistance and predictable wear tendency		
Composition	Color	Density(g/cm ³)	Hardness(HRA)	Toughness(MPa·m ^{1/2})
WC, PVD coating	Black	15.0	92.50	9.00

Recommended Cutting Condition

Work Material	Machining	Vc	Feed(mm/rev)	DOC(mm)	Coolant
HRSA(Inconel 718)	Finishing	100-300	0.05~0.2	~1.0	○
Ti - Alloy(TiAl ₄ V)	Finishing	50-150	0.05~0.2	~1.0	○

GRADE INFORMATION

PCBN / PCD

Union PCBN is an ultra hard cutting tool consisting of polycrystalline cubic boron nitride with metallic or ceramic binder. It is available both tip brazed and solid CBN.

Union PCD is an ultra hard cutting tool consisting of polycrystalline diamond which is tip brazed to a carbide insert according to the various applications.

- PCBN is for hardened ferrous material
- PCD is for non-ferrous material, wood and aluminum and copperalloys at extremely high speed
- Extremely hard and wear-resistant
- Dry or wet machining depending on the cutting condition

Grade	Properties	Applications	Toughness		
				Harder	Tougher
PCBN	SBN1000 SBC1000	Ultra high hardness Its hardness is up to 3,900 Hv Content of PCBN : 95%	Ultra cutting speed for cast iron from roughing to finishing Machining chilled cast irons and high chrome alloy steel	Harder ↑ ↓ Tougher ↑ Harder	
	SBN2000 SBC2000	Machining for continuous cut of hardened steel Its hardness is up to 2,700 Hv Content of PCBN : 50%	Precision finishing of hardened steel Recommended to use for hard materials Bearing steel, forged steel and high speed steel		
	SBN3000 SBC3000	Best combination of wear resistance and toughness Its hardness is up to 2,700 Hv Content of PCBN : 60%	Light interrupted cut of hardened steel General purpose of turning and milling for hardened steel		
	SBN4000 SBC4000	Good resistance to crater and flank wear Its hardness is up to 2,900 Hv Content of PCBN : 65%	Heavy interrupted cut of hardened steel		
	SBN5000 SBC5000	Extreme wear resistance Solid CBN Content of PCBN : 93%	Rough machining of cast iron powder metal alloy		
	PCD	SPD1000	Machining with fine surface finish Particle size : 4~5µm		Machining of aluminum and wood Gives fine surface finish in turning operation
		SPD2000	Ultra high hardness Great wear resistance Particle size : 8~9µm		The first choice of PCD grades Turning operation of aluminum and copper alloy Machining aluminum alloy with lower percentage of Si
		SPD3000	Machining with interruption Particle size : 15~22µm		Milling operation of aluminum alloy Machining ultra fine alloy and powder sintered metal cutting of composites
		SPD4000	Specialized in machining for CFRP Particle size : 2 & 30µm		Milling operation for CFRP stacks with aluminum Machining lightweight and fibrous materials.

Recommended Cutting Conditions

Application	Grade	Workpiece	Speed (V) (m/min)	Feed (f) (mm/rev)	Depth (DOC) (mm)		
Turning	PCBN	SBN1000 SBC1000	Cast iron High hardened cast iron Nodular cast iron roll Carbide roll	400 ~ 1,000 75 ~ 150 45 ~ 60 10 ~ 15	0.15 ~ 0.45 0.15 ~ 0.30 0.60 ~ 0.80 0.15 ~ 0.25	0.10 ~ 2.00 0.10 ~ 1.80 2.00 ~ 3.50 0.50 ~ 2.50	
		SBN2000 SBC2000	High hardened steel (roughing) High hardened steel (finishing, >H _R C 45) Hardened alloy steel (>H _R C 35)	60 ~ 140 100 ~ 140 100 ~ 240	0.15 ~ 0.40 0.10 ~ 0.20 0.05 ~ 0.30	0.70 ~ 2.30 0.10 ~ 0.75 0.10 ~ 2.50	
		SBN3000 SBC3000	Hardened steel Heat resistance sintered steel	80 ~ 160 50 ~ 100	0.02 ~ 0.20 0.05 ~ 0.20	<0.5 <0.5	
		SBN4000 SBC4000	Hardened steel Powder metal & Sintered irons superalloys	120 ~ 250 200 ~ 400 200 ~ 400	0.025 ~ 0.50 0.025 ~ 0.20 0.10 ~ 0.30	0.05 ~ 0.30 0.05 ~ 0.20 0.20 ~ 2.00	
		SBN5000 SBC5000	Cast iron Ductile cast iron Hard cast iron (H _R C 59)	500 ~ 2,000 200 ~ 600 50 ~ 150	0.10 ~ 0.50 0.10 ~ 0.40 0.10 ~ 1.00	<0.5 <0.5 <0.5	
	PCD	SPD1000	Plastic alloy Wood	300 ~ 1,000 1,000 ~ 2,500	0.05 ~ 0.25 0.10 ~ 0.50	0.05 ~ 3.00 0.20 ~ 4.50	
		SPD2000	Aluminum / Zinc / Copper	600 ~ 1,000	0.05 ~ 0.25	0.05 ~ 0.30	
		SPD2000 SPD3000 SPD3000	Aluminum alloy (Si 4~8%) (Si 9~14%) (Si 16~18%)	800 ~ 2,500 500 ~ 1,290 300 ~ 600	0.10 ~ 0.30 0.10 ~ 0.30 0.10 ~ 0.30	0.05 ~ 3.00 0.05 ~ 3.00 0.05 ~ 3.00	
		SPD3000	Powdered Carbide Piece Sintered Carbide	50 ~ 250 20 ~ 40	0.10 ~ 0.40 0.05 ~ 0.20	0.10 ~ 4.00 0.02 ~ 0.45	
		SPD4000	CFRP Aluminum alloy (Si 18~21%)	200 ~ 500 200 ~ 500	0.1 ~ 0.5 0.1 ~ 0.5	0.1 ~ 0.4 0.1 ~ 0.4	
	Milling	PCBN	SBN1000	Cast iron (H _B 180~230) Hardened cast iron (>H _B 400)	400 ~ 1,000 120 ~ 240	0.12 ~ 0.30 0.12 ~ 0.30	0.20 ~ 2.00 0.20 ~ 2.00
			SBN2000	Hardened steel (>H _R C 45) Hardened alloy steel (>H _R C 35)	120 ~ 240 120 ~ 240	0.10 ~ 0.25 0.10 ~ 0.35	0.12 ~ 1.00 0.10 ~ 1.00
			SBN3000 SBN4000	Hardened steel (>H _R C 45) Hardened steel	100 ~ 200 150 ~ 250	0.10 ~ 0.15 0.025 ~ 0.30	<0.5 0.05 ~ 0.20
		PCD	SPD3000	Aluminum alloy (<Si 14%) (>Si 15%)	300 ~ 3,000 100 ~ 240	0.10 ~ 0.25 0.10 ~ 0.35	0.12 ~ 1.00 0.10 ~ 1.00
SPD4000			CFRP Aluminum alloy (Si 18~21%)	300 ~ 1,000 300 ~ 1,000	0.1 ~ 0.3 0.1 ~ 0.3	0.1 ~ 0.3 0.1 ~ 0.3	

Physical Properties

Grade	Contents of pCBN (%)	Particle size (µm)	Hardness (HV)
SBN1000 SBC1000	95	3	3,900
SBN2000 SBC2000	50	1	2,700
SBN3000 SBC3000	60	2	2,700
SBN4000 SBC4000	65	5	2,900
SBN5000 SBC5000	93	10	3,900

Grade	Particle size (µm)	Hardness (HV)
SPD1000	4 ~ 5	6,000 ~ 8,000
SPD2000	8 ~ 9	7,000 ~ 9,000
SPD3000	15 ~ 22	8,000 ~ 10,000
SPD4000	2 & 30	5,000 ~ 8,000











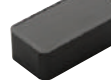







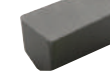











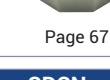

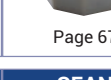



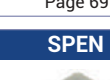



















APPLICATION INDEX

CERAMIC

TURNING

CNGA  Page 24	CNMA  Page 25	CNGN  Page 26	CNMN  Page 27	CNGX  Page 28	CNVX  Page 28	CNMX  Page 29
CNMX .. RD  Page 29	CCGX  Page 29	CCGW  Page 30	CPGN  Page 31	DNGA  Page 32	DNMA  Page 32	DNGN  Page 33
DNGX  Page 34	DNMX  Page 34	DCGX  Page 34	ENGN  Page 35	RNGA  Page 36	RNGN  Page 36	RPGA  Page 37
RPGN  Page 37	RPGN .. DP  Page 38	RNGX .. DP  Page 38	RBGN  Page 39	RCGN  Page 39	SCGA  Page 40	SNMA  Page 40
SNGN  Page 41	SNGX  Page 42	SNMX  Page 42	SNMX .. RD  Page 42	SCGN  Page 43	SCGX  Page 43	SCGW  Page 43
SPGN  Page 44	SPGN ... CR  Page 44	SNHN ... CR  Page 44	TNGA  Page 45	TNGN  Page 46	TCUN  Page 47	TPGN  Page 48
TPUN  Page 48	VNGA  Page 49	VNGN  Page 49	VNGX  Page 50	WNGA  Page 51	WNGX  Page 51	CDH  Page 52
F-Series  Page 53	F-Series  Page 53	F-Series  Page 53	F-Series  Page 53	F-Series  Page 54	F-Series  Page 54	F-Series  Page 54

TURNING

LNJ  Page 55	SNGN3812R  Page 55	RBGX  Page 56	RCGX  Page 56	RPGX  Page 57	RXGX  Page 57	SYBF  Page 58
SYBF .. K  Page 58	SYBR  Page 58	SGF  Page 59	SGR  Page 59	SSF  Page 60	SSR  Page 60	WFC  Page 61
WRC  Page 62	WFP  Page 63	WRP  Page 64	SRG  Page 65	SRGA  Page 65		
HNEN  Page 66	LNE  Page 66	OEGB  Page 67	OEGB ... CR  Page 67	OPEN  Page 67	SNCN  Page 68	SNCN .. ENTN  Page 68
SNGN .. ING  Page 68	SDCN  Page 69	SDCN .. T  Page 69	SDCW  Page 69	SEAN  Page 70	SEAN .. NW  Page 70	SEAN .. T  Page 70
SPCN .. T  Page 71	SPCW  Page 71	SPEN  Page 71	SPHX  Page 72	SPKN  Page 72	SPKN .. SP  Page 72	TNCN  Page 73
TEKN  Page 73	TPKN  Page 73	CNGN .. AZ  Page 74	SNCN .. ZZT  Page 75	SNCN .. GZ  Page 75	SNCN .. KZ  Page 75	SCGN .. WZ  Page 76
SCGN .. XZ  Page 76	SCGN .. ZZ  Page 76	SCGN .. MZ  Page 77	SCGN .. ZM  Page 77			
SVW  Page 78	GVCN  Page 78	SZT 5810  Page 79	SNMX  Page 79	SNGF  Page 80	INGN  Page 80	ENDMILL  Page 81

MILLING











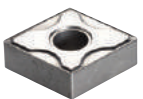

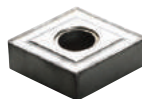

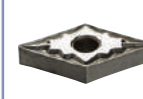
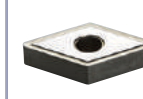

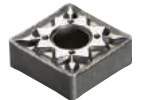
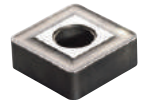

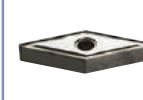



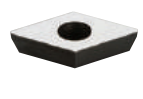

SPECIAL

APPLICATION INDEX

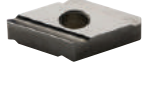









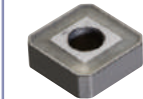

CERMET

TURNING
&
MILLING

TURNING

CNMG .. SF  Page 86	CNMG .. SY  Page 86	CNMG .. SG  Page 86	DNMG .. SF  Page 87	DNMG .. SY  Page 87	DNMG .. SG  Page 87	SNMG .. SF  Page 88
SNMG .. SY  Page 88	SNMG .. SG  Page 88	TNMG .. SY  Page 89	TNMG .. SG  Page 89	VNMG .. SG  Page 89	WNMG .. SY  Page 90	WNMG .. SG  Page 90
CCMT  Page 91	DCGW  Page 91	CPGT  Page 91	SPGT  Page 92	TPGT  Page 92	TPGT .. KC  Page 92	TPGR  Page 93
SPMW  Page 93	DNGG  Page 94	SNGG  Page 94	SNGL  Page 94	TNGG  Page 95	TNGG .. FS  Page 95	TNGG .. F  Page 95
TNMG .. 2G						
 Page 96						

MILLING

SDCN  Page 97	SDKN  Page 97	SDEN  Page 97	SDEW  Page 98	SNK  Page 98	SEHW  Page 98	SEKN  Page 99
SEKN .. R  Page 99	SPKN  Page 99	TEKN  Page 98	TPKN  Page 100	YCE  Page 101	XCET  Page 101	

SPECIAL























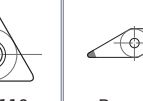









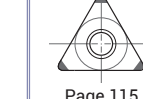

BSN  Page 102	BTN  Page 102	GBF  Page 103	INGN  Page 103	RBAR  Page 104	SBAR  Page 106
---	---	---	--	---	--

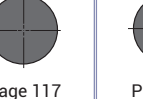
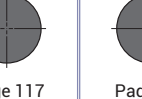
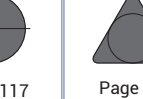
APPLICATION INDEX

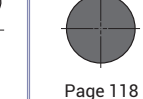



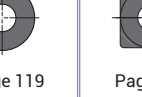

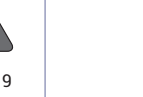









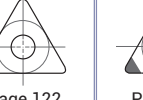

PCBN·PCD

TURNING
&
MILLING







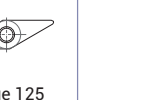





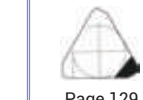

PCBN

CNGA  Page 110	CCGW  Page 110	DNGA  Page 110	DNGA ... CB  Page 110	DCGW  Page 110	SNGA  Page 111	SNGN  Page 111	SCGW  Page 111
TNGA  Page 111	TCGW  Page 112	TPGN  Page 112	TPGB  Page 112	TPGW  Page 112	VNGA  Page 113	VBGW  Page 113	VCGW  Page 113
CNGA  Page 114	CCGW  Page 114	DCGW  Page 114	SNGA  Page 114	SCGW  Page 115	DNGA  Page 115	TNGA  Page 115	TPGW  Page 115
VNGA  Page 116	VBGW  Page 116	RCGX  Page 117	RNGN  Page 117	RPGN  Page 117	TBGN  Page 117	CNGN  Page 118	RNGN  Page 118
SNGN  Page 118	TNGN  Page 118	CNGA  Page 119	RNGA  Page 119	SNGA  Page 119	TNGA  Page 119		

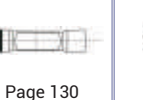
PCD

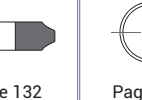
CNGA  Page 120	CCGW  Page 120	CPGW  Page 120	DNGA  Page 120	DCGW  Page 121	SNGA  Page 121	SNGN  Page 121	SCGW  Page 121
SPGN  Page 122	SPGW  Page 122	TNGA  Page 122	TBGW  Page 122	TCGW  Page 123	TPGN  Page 123	TPGB  Page 123	TPGW  Page 124
TPGT  Page 124	VNGA  Page 124	VBGW  Page 124	VCGW  Page 125				

SPECIAL

TCGW/TPGW .. FS  Page 126	CCGW .. FS  Page 126	SCGW .. FS  Page 127	SPGW .. FS  Page 127	SPCN  Page 128	SPKN  Page 128	SFCN  Page 129	TPCN  Page 129
UGMR  Page 130	UGMT  Page 130	UTGR/L  Page 131	NOTCH BITE  Page 132	SFE .. 1C  Page 133	SFE .. 2C  Page 133	SBE .. 1C  Page 134	SBN .. 2C  Page 134

IDENTIFICATION SYSTEM

ISO **TURNING**
ASA
MILLING

S N G N
S N G N
S P K N
1 2 3 4

12 04 08 E040
4 3 2
4 3
5 6 7 8 9 10 11 12

1 Shape

C D E H L
R S T V W

2 Clearance Angle

B C D E
N P O

Other Clearance Angles Requiring Descriptions

3 Tolerance

*See tables below

Symbol	d(mm)	m(mm)	s(mm)
A	±0.025	±0.005	±0.025
C	±0.025	±0.013	±0.025
E	±0.025	±0.025	±0.025
F	±0.013	±0.005	±0.025
G	±0.025	±0.025	±0.130
H	±0.013	±0.013	±0.025
J	*	±0.005	±0.025
K	*	±0.013	±0.025
L	*	±0.025	±0.025
M	*	*	±0.127
U	*	*	±0.127
N	*	*	±0.025

IC (mm)	D		C, E, H, O, S, T, R, W			
	d(mm)	m(mm)	d(mm)		m(mm)	
	M, N	M, N	J, K, L, M, N	U	M, N	U
5.56	±0.05	±0.11	±0.05	±0.08	±0.08	±0.13
6.35	±0.05	±0.11	±0.05	±0.08	±0.08	±0.13
7.94	±0.05	±0.11	±0.05	±0.08	±0.08	±0.13
9.52	±0.05	±0.11	±0.05	±0.08	±0.08	±0.13
12.70	±0.08	±0.15	±0.08	±0.13	±0.13	±0.20
15.87	±0.10	±0.18	±0.10	±0.18	±0.15	±0.27
19.05	±0.10	±0.18	±0.10	±0.18	±0.15	±0.27
25.40	-	-	±0.13	±0.25	±0.18	±0.38

4 Type

A B C F G H J M
N Q R T U W X

Special design

5 Cutting Edge Length

Diameter of inscribed circle	ASA		ISO						
	over 6.35 (IC)	over 5.56 (IC)	R	W	V	D	C	S	T
3.969	-	5	03	02	-	04	03	03	06
4.762	-	6	04	03	-	05	04	04	08
5.556	-	7	05	03	09	06	05	05	09
6.350	2	(8)	06	04	11	07	06	06	11
7.938	-	0	07	05	13	09	08	07	13
9.525	3	-	09	06	16	11	09	09	16
12.700	4	-	12	08	22	15	12	12	22
15.875	5	-	15	10	27	19	16	15	27
19.050	6	-	19	13	33	23	19	19	33
22.225	7	-	22	-	38	27	22	22	38
25.400	8	-	25	-	44	31	25	25	44
31.750	0	-	31	-	54	38	32	31	55

6 Thickness

Thickness(mm)	ISO	ASA	
		Over 6.35(IC)	Over 5.56(IC)
1.59	01	-	2
2.38	02	-	3
3.18	03	2	4
3.97	T3	-	5
4.76	04	3	6
5.56	05	-	-
6.35	06	4	-
7.94	07	5	-
9.52	09	6	-
12.70	12	8	-

7 Nose-Radius

(mm)	ISO	ASA
Sharp	00	0
0.2	02	Y
0.4	04	1
0.8	08	2
1.2	12	3
1.6	16	4
2.0	20	5
2.4	24	6
2.8	28	7
3.2	32	8

8 Shape and Corner

Detailed edge preparations refer to the next page.

9 Land Angle

A	45°
D	60°
E	75°
F	85°
P	90°

10 Relief Angle for Land

A	3°
B	5°
C	7°
D	15°
E	20°
F	25°
N	0°
P	11°

11 Edge

F	Sharp
E	Honed
T	Chamfered
S	Chamfered + Honed

12 Cutting Direction

R L N

IDENTIFICATION SYSTEM

8 Chamfer Specification

1 Mono chamfer

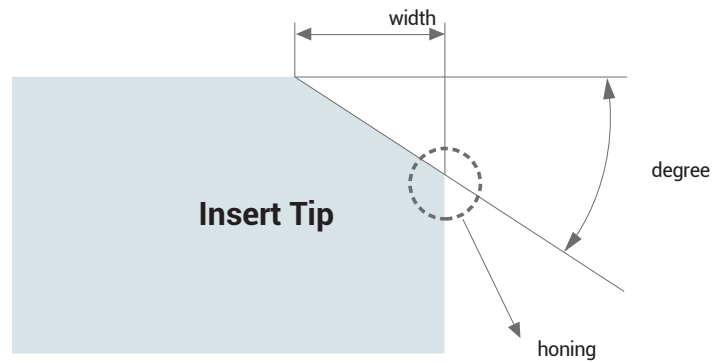

ISO

SNGN 120408 E 0 4 0

Chamfer Degree (°)	Chamfer Width (mm)		Honing (µm)
E : 20	01 : 0.05	10 : 0.50	0 : No Honing
F : 25	02 : 0.10	20 : 1.00	1 : 10
G : 30	03 : 0.15	40 : 2.00	2 : 20
	04 : 0.20		3 : 30

2 Double chamfer

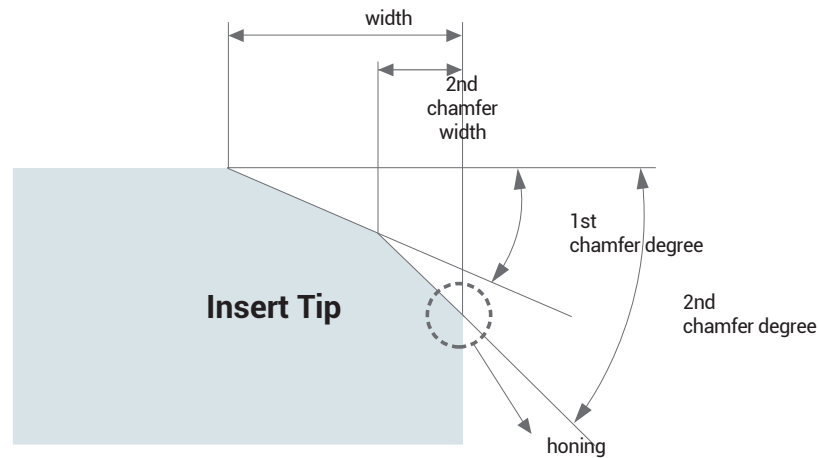

ISO

SNGN 190716 X 5 4 2

1st Chamfer Degree (°)	1st Chamfer Width (mm)		2nd Chamfer Width(mm)×Degree		Honing (µm)
W : 10	3 : 1.00	A : 0.75	3 : 0.20×25	A : 0.15×30	0 : No Honing
X : 15	4 : 1.20	B : 1.25	4 : 0.10×30	B : 0.45×25	1 : 10
	5 : 1.50	D : 2.30	5 : 0.20×30		2 : 20
	6 : 2.00				3 : 30
					5 : 50

SiAlON (SN950)

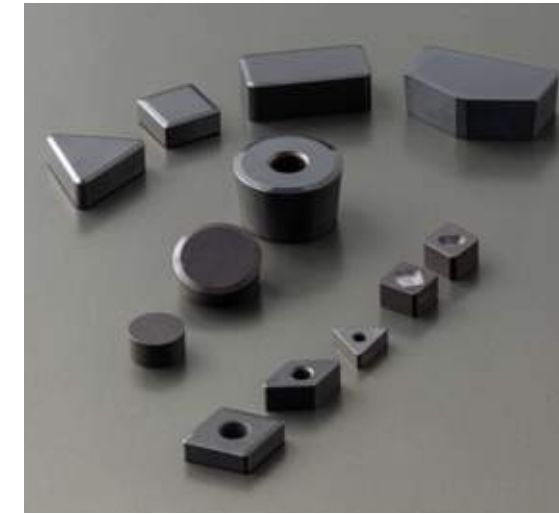

Grade	Application Range & Characteristics
SN950	- Roughing & Semi-finishing for HRSA (Heat Resistant Super Alloys) - Reinforced toughness and β'-SiAlON phase
SN800	- High Speed roughing of high temperature alloy and Inconel
SN1000	- Ni-based alloys, Co-based alloys in medium or low speed cutting

SN950 Application

- Workpiece : Inconel 718
- Insert Shape : RNGN 120700 E020 (RNG 45 T01020)
- Test conditions : Vc 230 m/min, Feed 0.2 mm/rev DOC 1.0 mm, WET
- Cutting Distance : 1.5 km

Union SN950

	0.267mm		
0.1	0.2	0.3	0.4
			0.429mm
0.1	0.2	0.3	0.4

Competitor

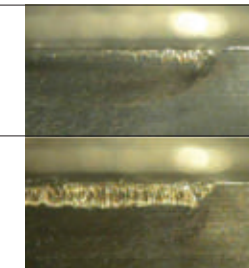

Flank Wear
(Vbmax. mm)

Whisker Grade (SW400/SW800)



Grade	Application Range & Characteristics
SW400	- High Speed Steel, High Chrome Steel in medium or low speed cutting - Roughing & Medium cutting with heavy interruption
SW800	- Ni-based alloys, Co-based alloys in high speed cutting - Roughing & Finishing with continuous or light interruption

- Best Performance for HRSA (Inconel, Waspaloy, Stellite)
- For High-Speed machining of HRSA with Optimized Heat and Fracture resistance

CERAMIC

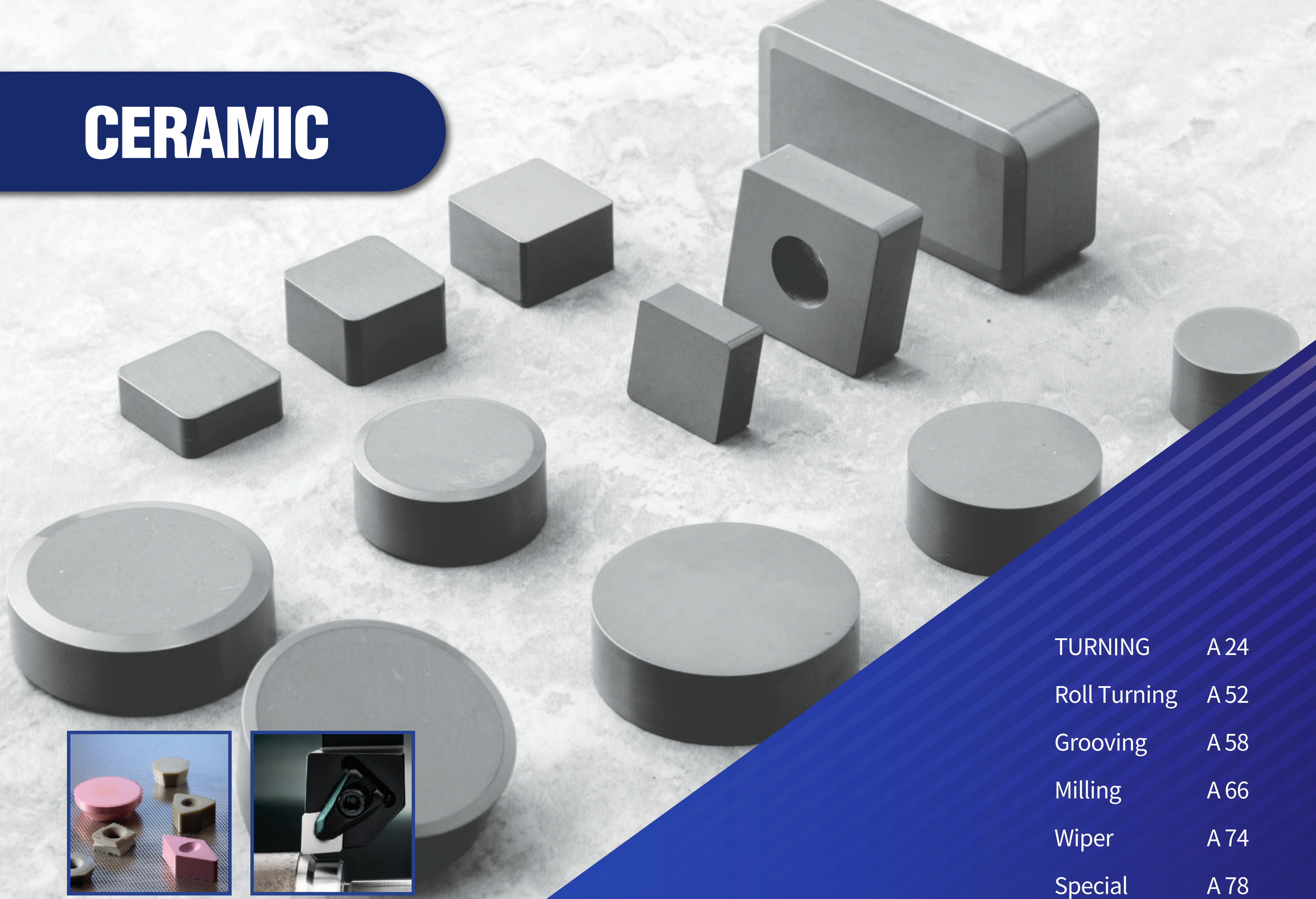

TURNING	A 24
Roll Turning	A 52
Grooving	A 58
Milling	A 66
Wiper	A 74
Special	A 78

TURNING INSERT

CNGA

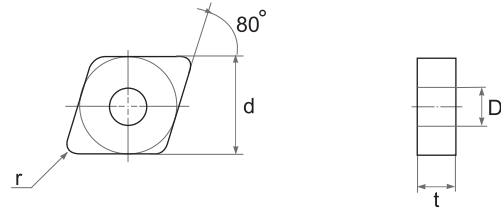
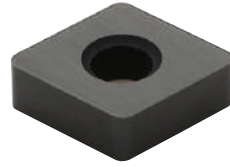

Type		Dimensions (mm)				ST100	ST300	ST500	ST900	SD200	SZ200	SZ300	SN26	SN300	SN400	SN500	SN600	SN800	SN950	SN1000	SW400	SW800	Coated ST	Coated SN	Coated SW
ISO	ASA	d	t	r	D																				
CNGA 120404	CNGA 431	12.70	4.76	0.4	5.16	●	●	●	●	●		●						●		●					
CNGA 120408	CNGA 432	12.70	4.76	0.8	5.16	●	●	●	●	●	●	●	●	●	●	●	●	●		●	●	●			
CNGA 120412	CNGA 433	12.70	4.76	1.2	5.16	●	●			●	●	●	●	●	●	●	●	●		●	●	●			
CNGA 120416	CNGA 434	12.70	4.76	1.6	5.16	●	●			●		●	●	●			●			●	●	●			
CNGA 120704	CNGA 451	12.70	7.94	0.4	5.16																				
CNGA 120708	CNGA 452	12.70	7.94	0.8	5.16	●	●			●		●	●												
CNGA 120712	CNGA 453	12.70	7.94	1.2	5.16	●	●	●		●		●	●					●		●	●	●			
CNGA 120716	CNGA 454	12.70	7.94	1.6	5.16	●				●		●	●					●		●					
CNGA 160608	CNGA 542	15.87	6.35	0.8	6.35							●													
CNGA 160612	CNGA 543	15.87	6.35	1.2	6.35							●	●	●							●	●			
CNGA 160616	CNGA 544	15.87	6.35	1.6	6.35	●								●											
CNGA 160708	CNGA 552	15.87	7.94	0.8	6.35	●	●																		
CNGA 160712	CNGA 553	15.87	7.94	1.2	6.35	●	●						●												
CNGA 160716	CNGA 554	15.87	7.94	1.6	6.35								●												
CNGA 190608	CNGA 642	19.05	6.35	0.8	7.93	●						●	●					●		●					
CNGA 190612	CNGA 643	19.05	6.35	1.2	7.93							●									●	●			
CNGA 190616	CNGA 644	19.05	6.35	1.6	7.93	●	●																		
CNGA 190712	CNGA 653	19.05	7.94	1.2	7.93																				
CNGA 190716	CNGA 654	19.05	7.94	1.6	7.93	●																			

TURNING INSERT

CNMA

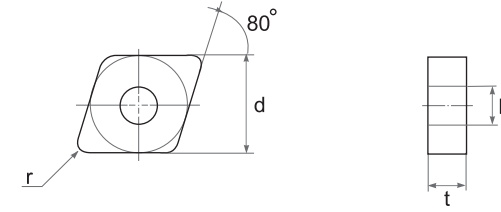
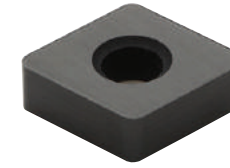

Type		Dimensions (mm)				ST100	ST300	ST500	ST900	SD200	SZ200	SZ300	SN26	SN300	SN400	SN500	SN600	SN800	SN950	SN1000	SW400	SW800	Coated ST	Coated SN	Coated SW
ISO	ASA	d	t	r	D																				
CNMA 120408	CNMA 432	12.70	4.76	0.8	5.16									●	●										
CNMA 120412	CNMA 433	12.70	4.76	1.2	5.16									●	●	●	●	●		●					
CNMA 120416	CNMA 434	12.70	4.76	1.6	5.16									●	●	●	●	●		●					
CNMA 160612	CNMA 543	15.87	6.35	1.2	6.35									●		●									
CNMA 160616	CNMA 544	15.87	6.35	1.6	6.35									●		●									

TURNING INSERT

CNGN

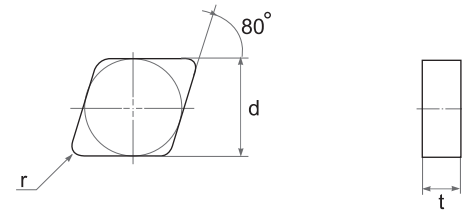
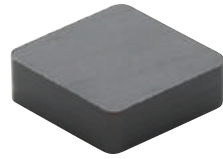

Type		Dimensions (mm)			ST100	ST300	ST500	ST900	SD200	SZ200	SZ300	SN26	SN300	SN400	SN500	SN600	SN800	SN950	SN1000	SW400	SW800	Coated ST	Coated SN	Coated SW
ISO	ASA	d	t	r																				
CNGN 090304	CNGN 321	9.52	3.18	0.4	●																			
CNGN 090308	CNGN 322	9.52	3.18	0.8		●										●	●			●				
CNGN 090312	CNGN 323	9.52	3.18	1.2												●	●			●				
CNGN 120304	CNGN 421	12.70	3.18	0.4	●																			
CNGN 120308	CNGN 422	12.70	3.18	0.8	●																			
CNGN 120312	CNGN 423	12.70	3.18	1.2	●																			
CNGN 120404	CNGN 431	12.70	4.76	0.4	●	●			●	●														
CNGN 120408	CNGN 432	12.70	4.76	0.8	●	●	●	●	●	●	●			●	●				●	●	●			
CNGN 120412	CNGN 433	12.70	4.76	1.2	●	●	●	●	●	●				●	●	●			●	●	●			
CNGN 120416	CNGN 434	12.70	4.76	1.6	●	●	●		●					●	●	●			●	●	●			
CNGN 120704	CNGN 451	12.70	7.94	0.4																	●	●		
CNGN 120708	CNGN 452	12.70	7.94	0.8								●	●					●		●				
CNGN 120712	CNGN 453	12.70	7.94	1.2	●	●			●	●				●	●				●	●	●			
CNGN 120716	CNGN 454	12.70	7.94	1.6	●	●			●	●				●	●				●	●	●			
CNGN 160608	CNGN 542	15.87	6.35	0.8																				
CNGN 160612	CNGN 543	15.87	6.35	1.2	●										●						●	●		
CNGN 160616	CNGN 544	15.87	6.35	1.6	●																			
CNGN 160708	CNGN 552	15.87	7.94	0.8	●					●														
CNGN 160712	CNGN 553	15.87	7.94	1.2	●	●	●							●	●									
CNGN 160716	CNGN 554	15.87	7.94	1.6	●	●	●			●				●	●									
CNGN 160720	CNGN 555	15.87	7.94	2.0	●									●	●									
CNGN 190612	CNGN 643	19.05	6.35	1.2	●	●																		
CNGN 190616	CNGN 644	19.05	6.35	1.6	●	●																		
CNGN 190712	CNGN 653	19.05	7.94	1.2	●	●																		
CNGN 190716	CNGN 654	19.05	7.94	1.6	●	●																		
CNGN 190720	CNGN 655	19.05	7.94	2.0	●																			
CNGN 250724	CNGN 856	25.40	7.94	2.4	●																			
CNGN 250924	CNGN 866	25.40	9.52	2.4	●	●	●					●												

CERAMIC

CERMET

PCBN / PCD

TOOL HOLDER

MILLING CUTTER

TURNING INSERT

CNMN

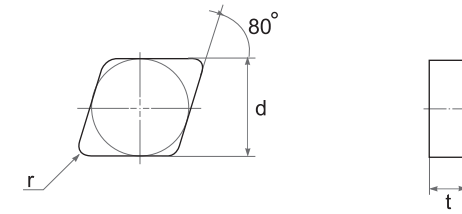
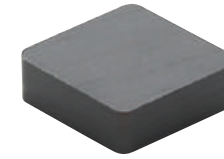

Type		Dimensions (mm)			ST100	ST300	ST500	ST900	SD200	SZ200	SZ300	SN26	SN300	SN400	SN500	SN600	SN800	SN950	SN1000	SW400	SW800	Coated ST	Coated SN	Coated SW
ISO	ASA	d	t	r																				
CNMN 120412	CNMN 433	12.70	4.76	1.2										●			●		●					
CNMN 120416	CNMN 434	12.70	4.76	1.6										●			●		●					

CERAMIC

CERMET

PCBN / PCD

TOOL HOLDER

MILLING CUTTER

TURNING INSERT

CNGX

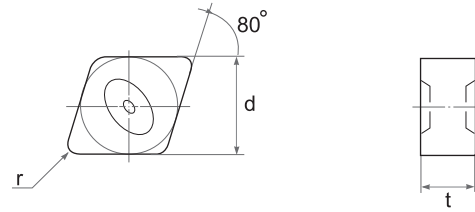
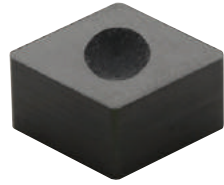

Type		Dimensions (mm)			ST100	ST300	ST500	ST900	SD200	SZ200	SZ300	SN26	SN300	SN400	SN500	SN600	SN800	SN950	SN1000	SW400	SW800	Coated ST	Coated SN	Coated SW	
ISO	ASA	d	t	r																					
CNGX 120412	CNGX 433	12.70	4.76	1.2									●	●											
CNGX 120416	CNGX 434	12.70	4.76	1.6										●											
CNGX 120708	CNGX 452	12.70	7.94	0.8	●	●							●												
CNGX 120712	CNGX 453	12.70	7.94	1.2	●	●							●	●	●										
CNGX 120716	CNGX 454	12.70	7.94	1.6	●	●							●	●	●	●									
CNGX 160708	CNGX 552	15.87	7.94	0.8									●												
CNGX 160712	CNGX 553	15.87	7.94	1.2									●	●	●										
CNGX 160716	CNGX 554	15.87	7.94	1.6									●	●											

CNVX

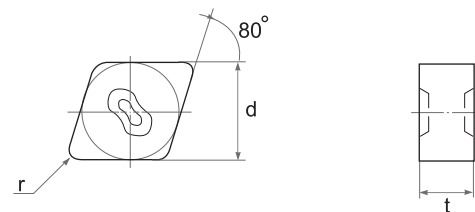
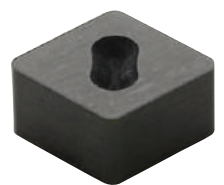

Type		Dimensions (mm)			ST100	ST300	ST500	ST900	SD200	SZ200	SZ300	SN26	SN300	SN400	SN500	SN600	SN800	SN950	SN1000	SW400	SW800	Coated ST	Coated SN	Coated SW	
ISO	ASA	d	t	r																					
CNVX 120412	CNVX 433	12.70	4.76	1.2										●											
CNVX 120416	CNVX 434	12.70	4.76	1.6										●											
CNVX 120708	CNVX 452	12.70	7.94	0.8	●					●			●												
CNVX 120712	CNVX 453	12.70	7.94	1.2	●	●				●			●	●	●	●	●		●						
CNVX 120716	CNVX 454	12.70	7.94	1.6		●		●		●			●	●	●	●	●		●						

TURNING INSERT

CNMX

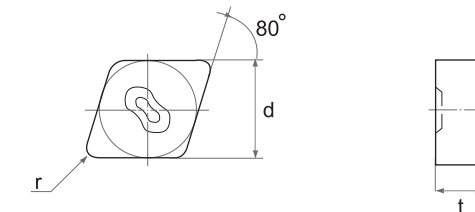

Type		Dimensions (mm)			ST100	ST300	ST500	ST900	SD200	SZ200	SZ300	SN26	SN300	SN400	SN500	SN600	SN800	SN950	SN1000	SW400	SW800	Coated ST	Coated SN	Coated SW	
ISO	ASA	d	t	r																					
CNMX 120712	CNMX 453	12.70	7.94	1.2									●	●	●										
CNMX 120716	CNMX 454	12.70	7.94	1.6									●	●	●	●		●							

CNMX .. RD

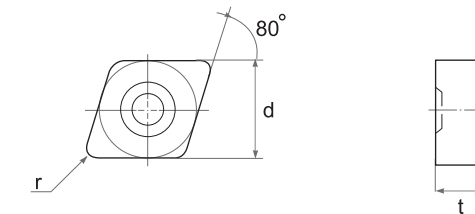

Type		Dimensions (mm)			ST100	ST300	ST500	ST900	SD200	SZ200	SZ300	SN26	SN300	SN400	SN500	SN600	SN800	SN950	SN1000	SW400	SW800	Coated ST	Coated SN	Coated SW	
ISO	ASA	d	t	r																					
CNMX 120716 RD	CNMX 454 RD	12.7	7.94	1.6									●	●											

CCGX

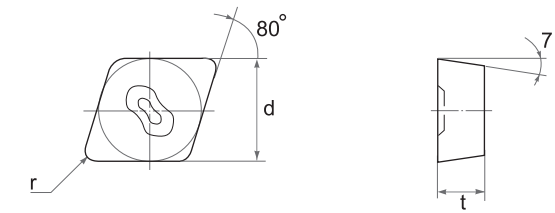

Type		Dimensions (mm)			ST100	ST300	ST500	ST900	SD200	SZ200	SZ300	SN26	SN300	SN400	SN500	SN600	SN800	SN950	SN1000	SW400	SW800	Coated ST	Coated SN	Coated SW	
ISO	ASA	d	t	r																					
CCGX 120608	CCGX 442	12.70	6.35	0.8										●											
CCGX 120612	CCGX 443	12.70	6.35	1.2										●	●	●	●		●						
CCGX 120616	CCGX 444	12.70	6.35	1.6										●											

TURNING INSERT

CCGW

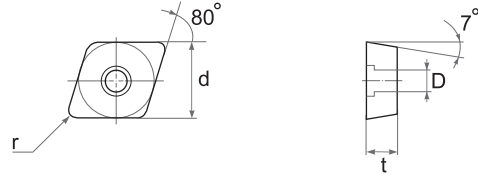

Type	Dimensions (mm)				ST100	ST300	ST500	ST900	SD200	SZ200	SZ300	SN26	SN300	SN400	SN500	SN600	SN800	SN950	SN1000	SW400	SW800	Coated ST	Coated SN	Coated SW	
	ISO	d	t	r																					D
CCGW 09T304	9.52	3.97	0.4	4.40					●				●	●											
CCGW 09T308	9.52	3.97	0.8	4.40					●				●	●		●									
CCGW 09T312	9.52	3.97	1.2	4.40									●	●		●									
CCGW 120408	12.70	4.76	0.8	5.50										●											
CCGW 120412	12.70	4.76	1.2	5.50										●											

TURNING INSERT

CPGN

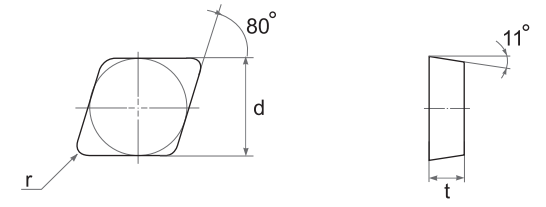
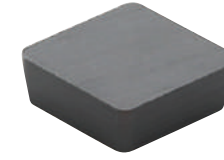

Type		Dimensions (mm)			ST100	ST300	ST500	ST900	SD200	SZ200	SZ300	SN26	SN300	SN400	SN500	SN600	SN800	SN950	SN1000	SW400	SW800	Coated ST	Coated SN	Coated SW								
ISO	ASA	d	t	r																												
CPGN 090304	CPGN 321	9.52	3.18	0.4																					●	●						
CPGN 090308	CPGN 322	9.52	3.18	0.8																											●	●
CPGN 120408	CPGN 432	12.70	4.76	0.8	●																										●	●
CPGN 120412	CPGN 433	12.70	4.76	1.2																												
CPGN 120416	CPGN 434	12.70	4.76	1.6																												

TURNING INSERT

DNGA

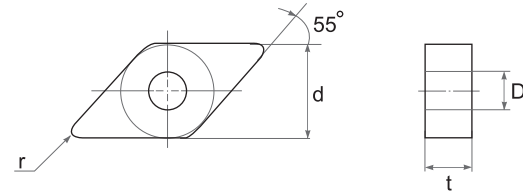
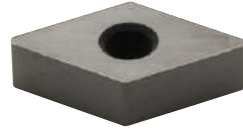

Type		Dimensions (mm)				ST100	ST300	ST500	ST900	SD200	SZ200	SZ300	SN26	SN300	SN400	SN500	SN600	SN800	SN950	SNT1000	SW400	SW800	Coated ST	Coated SN	Coated SW
ISO	ASA	d	t	r	D																				
DNGA 150404	DNGA 431	12.70	4.76	0.4	5.16	●	●	●													●	●			
DNGA 150408	DNGA 432	12.70	4.76	0.8	5.16	●	●	●				●	●	●							●	●			
DNGA 150412	DNGA 433	12.70	4.76	1.2	5.16	●	●	●						●	●	●		●			●	●			
DNGA 150416	DNGA 434	12.70	4.76	1.6	5.16	●						●									●	●			
DNGA 150604	DNGA 441	12.70	6.35	0.4	5.16	●	●	●	●	●		●													
DNGA 150608	DNGA 442	12.70	6.35	0.8	5.16	●	●	●	●	●		●		●											
DNGA 150612	DNGA 443	12.70	6.35	1.2	5.16	●	●	●	●			●		●	●			●			●				
DNGA 150616	DNGA 444	12.70	6.35	1.6	5.16	●	●	●																	
DNGA 150704	DNGA 451	12.70	7.94	0.4	5.16	●	●																		
DNGA 150708	DNGA 452	12.70	7.94	0.8	5.16	●	●				●	●	●	●											
DNGA 150712	DNGA 453	12.70	7.94	1.2	5.16	●	●				●	●	●	●			●				●				
DNGA 150716	DNGA 454	12.70	7.94	1.6	5.16	●																			
DNGA 190608	DNGA 542	15.87	6.35	0.8	6.35	●	●																		
DNGA 190612	DNGA 543	15.87	6.35	1.2	6.35	●	●				●	●		●			●								
DNGA 190616	DNGA 544	15.87	6.35	1.6	6.35	●																			

DNMA

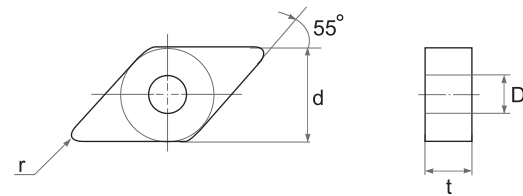
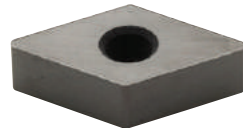

Type		Dimensions (mm)				ST100	ST300	ST500	ST900	SD200	SZ200	SZ300	SN26	SN300	SN400	SN500	SN600	SN800	SN950	SNT1000	SW400	SW800	Coated ST	Coated SN	Coated SW
ISO	ASA	d	t	r	D																				
DNMA 150612	DNMA 443	12.70	6.35	1.2	5.16									●	●										
DNMA 150616	DNMA 444	12.70	6.35	1.6	5.16										●										

TURNING INSERT

DNGN

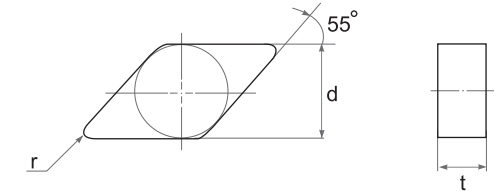
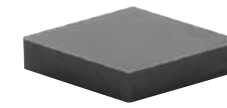

Type		Dimensions (mm)				ST100	ST300	ST500	ST900	SD200	SZ200	SZ300	SN26	SN300	SN400	SN500	SN600	SN800	SN950	SNT1000	SW400	SW800	Coated ST	Coated SN	Coated SW
ISO	ASA	d	t	r	D																				
DNGN 150404	DNGN 431	12.70	4.76	0.4																					
DNGN 150408	DNGN 432	12.70	4.76	0.8		●								●											
DNGN 150412	DNGN 433	12.70	4.76	1.2											●	●									
DNGN 150416	DNGN 434	12.70	4.76	1.6											●	●									
DNGN 150604	DNGN 441	12.70	6.35	0.4																					
DNGN 150608	DNGN 442	12.70	6.35	0.8		●		●						●			●		●						
DNGN 150612	DNGN 443	12.70	6.35	1.2		●	●	●						●			●		●						
DNGN 150616	DNGN 444	12.70	6.35	1.6																					
DNGN 150704	DNGN 451	12.70	7.94	0.4		●	●																		
DNGN 150708	DNGN 452	12.70	7.94	0.8		●	●	●	●		●	●	●	●				●		●					
DNGN 150712	DNGN 453	12.70	7.94	1.2		●	●	●	●		●	●	●	●			●		●						
DNGN 150716	DNGN 454	12.70	7.94	1.6		●	●				●	●	●	●			●		●						

TURNING INSERT

DNGX

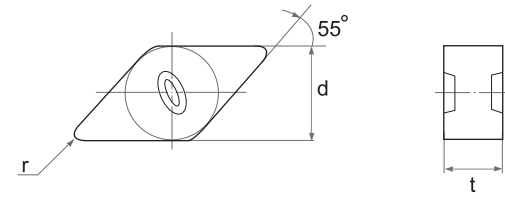
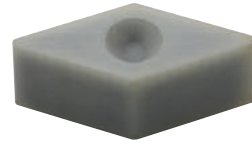

Type		Dimensions (mm)			ST100	ST300	ST500	ST900	SD200	SZ200	SZ300	SN26	SN300	SN400	SN500	SN600	SN800	SN950	SN1000	SW400	SW800	Coated ST	Coated SN	Coated SW	
ISO	ASA	d	t	r																					
DNGX 120708	DNGX 352	10.00	7.94	0.8						●				●											
DNGX 120712	DNGX 353	10.00	7.94	1.2						●			●	●	●	●			●						
DNGX 120716	DNGX 354	10.00	7.94	1.6						●			●	●	●										
DNGX 150708	DNGX 452	12.70	7.94	0.8																					
DNGX 150712	DNGX 453	12.70	7.94	1.2						●			●	●					●						
DNGX 150716	DNGX 454	12.70	7.94	1.6									●	●	●	●			●						

DNMX

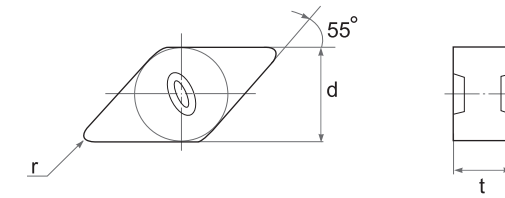
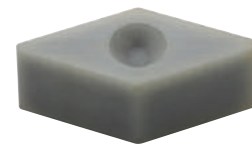

Type		Dimensions (mm)			ST100	ST300	ST500	ST900	SD200	SZ200	SZ300	SN26	SN300	SN400	SN500	SN600	SN800	SN950	SN1000	SW400	SW800	Coated ST	Coated SN	Coated SW	
ISO	ASA	d	t	r																					
DNMX 120708	DNMX 352	10.00	7.94	0.8											●										
DNMX 120712	DNMX 353	10.00	7.94	1.2										●	●										
DNMX 120716	DNMX 354	10.00	7.94	1.6										●	●	●									

DCGX

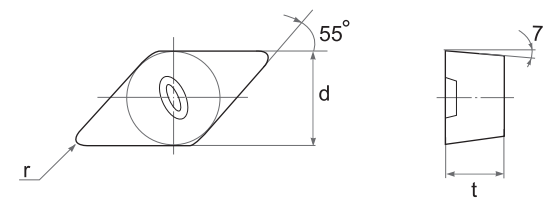

Type		Dimensions (mm)			ST100	ST300	ST500	ST900	SD200	SZ200	SZ300	SN26	SN300	SN400	SN500	SN600	SN800	SN950	SN1000	SW400	SW800	Coated ST	Coated SN	Coated SW	
ISO	ASA	d	t	r																					
DCGX 150612	DCGX 443	12.70	6.35	1.2										●		●									
DCGX 150616	DCGX 444	12.70	6.35	1.6										●		●									

TURNING INSERT

ENGN

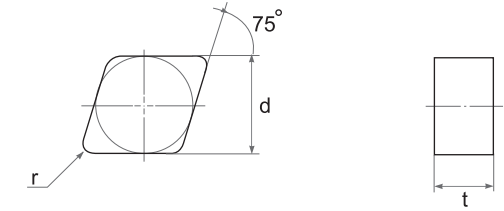
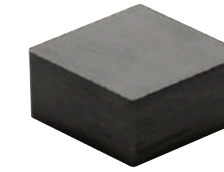

Type		Dimensions (mm)			ST100	ST300	ST500	ST900	SD200	SZ200	SZ300	SN26	SN300	SN400	SN500	SN600	SN800	SN950	SN1000	SW400	SW800	Coated ST	Coated SN	Coated SW	
ISO	ASA	d	t	r																					
ENGN 130404	ENGN 431	12.70	4.76	0.4																					
ENGN 130408	ENGN 432	12.70	4.76	0.8		●							●		●										
ENGN 130412	ENGN 433	12.70	4.76	1.2		●							●		●										
ENGN 130704	ENGN 451	12.70	7.94	0.4	●	●																			
ENGN 130708	ENGN 452	12.70	7.94	0.8	●	●	●	●		●	●	●	●	●	●										
ENGN 130712	ENGN 453	12.70	7.94	1.2	●	●	●	●					●	●	●			●	●	●	●				
ENGN 130716	ENGN 454	12.70	7.94	1.6	●	●				●			●	●	●										

TURNING INSERT

RNGA

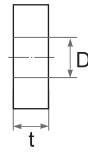
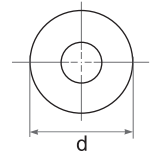

Type		Dimensions (mm)			ST100	ST300	ST500	ST900	SD200	SZ200	SZ300	SN26	SN300	SN400	SN500	SN600	SN800	SN950	SNT1000	SW400	SW800	Coated ST	Coated SN	Coated SW
ISO	ASA	d	t	D																				
RNGA 120400	RNGA 430	12.70	4.76	5.16	●	●																		
RNGA 120700	RNGA 450	12.70	7.94	5.16	●	●														●	●			

RNGN

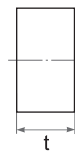
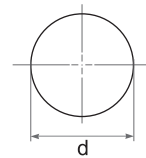

Type		Dimensions (mm)		ST100	ST300	ST500	ST900	SD200	SZ200	SZ300	SN26	SN300	SN400	SN500	SN600	SN800	SN950	SNT1000	SW400	SW800	Coated ST	Coated SN	Coated SW
ISO	ASA	d	t																				
RNGN 060300	RNGN 220	6.35	3.18		●																		
RNGN 060400	RNGN 230	6.35	4.76	●		●																	
RNGN 090300	RNGN 320	9.52	3.18	●		●					●	●											
RNGN 090400	RNGN 330	9.52	4.76	●	●	●		●			●					●		●	●	●			
RNGN 120300	RNGN 420	12.70	3.18								●					●		●					
RNGN 120400	RNGN 430	12.70	4.76	●	●	●		●	●		●	●	●	●	●	●		●	●	●			
RNGN 120600	RNGN 440	12.70	6.35																				
RNGN 120700	RNGN 450	12.70	7.94	●	●	●		●	●	●	●	●	●	●	●	●		●	●	●			
RNGN 150700	RNGN 550	15.87	7.94	●							●	●											
RNGN 190600	RNGN 640	19.05	6.35	●	●						●					●		●					
RNGN 190700	RNGN 650	19.05	7.94	●	●	●			●		●					●		●	●	●			
RNGN 250700	RNGN 850	25.40	7.94	●		●	●		●	●	●	●											
RNGN 250900	RNGN 860	25.40	9.52																				
RNGN 320900	RNGN 106	31.75	9.52	●																			
RNGN 0807MO		8.00	7.94	●																			
RNGN 1007MO		10.00	7.94	●																			
RNGN 1207MO		12.00	7.94	●																			

TURNING INSERT

RPGA

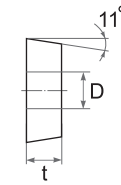
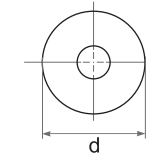

Type		Dimensions (mm)			ST100	ST300	ST500	ST900	SD200	SZ200	SZ300	SN26	SN300	SN400	SN500	SN600	SN800	SN950	SNT1000	SW400	SW800	Coated ST	Coated SN	Coated SW
ISO	ASA	d	t	D																				
RNGA 120400	RNGA 430	12.70	4.76	5.16	●																			
RNGA 120700	RNGA 450	12.70	7.94	5.16	●																			

RPGN

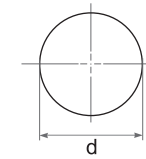
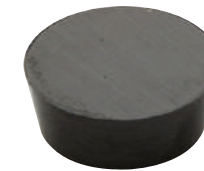

Type		Dimensions (mm)		ST100	ST300	ST500	ST900	SD200	SZ200	SZ300	SN26	SN300	SN400	SN500	SN600	SN800	SN950	SNT1000	SW400	SW800	Coated ST	Coated SN	Coated SW
ISO	ASA	d	t																				
RPGN 090300	RPGN 320	9.52	3.18	●	●											●	●						
RPGN 090400	RPGN 330	9.52	4.76	●	●	●																	
RPGN 120300	RPGN 420	12.70	3.18																				
RPGN 120400	RPGN 430	12.70	4.76	●	●								●			●		●	●	●			
RPGN 120700	RPGN 450	12.70	7.94	●	●											●		●					
RPGN 150700	RPGN 550	15.87	7.94																				
RPGN 190700	RPGN 650	19.05	7.94		●																		

TURNING INSERT

RPGX .. DP

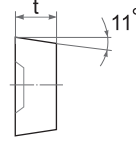
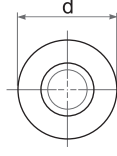

Type		Dimensions (mm)		ST100	ST300	ST500	ST900	SD200	SZ200	SZ300	SN26	SN300	SN400	SN500	SN600	SN800	SN950	SN1000	SW400	SW800	Coated ST	Coated SN	Coated SW		
ISO	ASA	d	t																						
RPGX 1204 DP	RPGX 43 DP	12.70	4.76													●			●						
RPGX 1207 DP	RPGX 45 DP	12.70	7.94													●			●						

RNGX .. DP

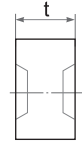
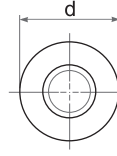

Type		Dimensions (mm)		ST100	ST300	ST500	ST900	SD200	SZ200	SZ300	SN26	SN300	SN400	SN500	SN600	SN800	SN950	SN1000	SW400	SW800	Coated ST	Coated SN	Coated SW	
ISO	ASA	d	t																					
RNGX 1207 DP	RNGX 45 DP	12.70	7.94												●	●		●						

TURNING INSERT

RBGN

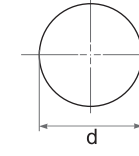
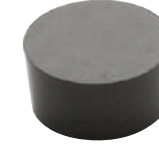

Type		Dimensions (mm)		ST100	ST300	ST500	ST900	SD200	SZ200	SZ300	SN26	SN300	SN400	SN500	SN600	SN800	SN950	SN1000	SW400	SW800	Coated ST	Coated SN	Coated SW		
ISO	ASA	d	t																						
RBGN 060300	RBGN 220	6.35	3.18	●																					
RBGN 060400	RBGN 230	6.35	4.76	●																					
RBGN 090300	RBGN 320	9.52	3.18	●																					
RBGN 090400	RBGN 330	9.52	4.76	●																					
RBGN 120400	RBGN 430	12.70	4.76	●	●	●							●												
RBGN 120600	RBGN 440	12.70	6.35	●																					
RBGN 120700	RBGN 450	12.70	7.94	●	●							●	●			●		●							
RBGN 0604MO		6.00	4.76	●	●																				
RBGN 0804MO		8.00	4.76	●	●																				
RBGN 1007MO		10.00	7.94	●										●											
RBGN 1207MO		12.00	7.94																						
RBGN 1607MO		16.00	7.94																						

RCGN

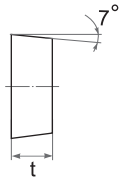
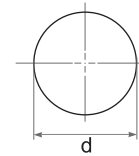

Type		Dimensions (mm)		ST100	ST300	ST500	ST900	SD200	SZ200	SZ300	SN26	SN300	SN400	SN500	SN600	SN800	SN950	SN1000	SW400	SW800	Coated ST	Coated SN	Coated SW		
ISO	ASA	d	t																						
RCGN 060400		6.35	4.76	●	●											●		●							
RCGN 060600		6.35	6.35	●	●	●					●					●		●							
RCGN 060700		6.35	7.94	●	●	●			●							●		●							
RCGN 070400		7.94	4.76		●																				
RCGN 090700		9.52	7.94	●	●	●						●				●		●							
RCGN 120700		12.70	7.94	●	●	●			●		●					●		●							
RCGN 151000		15.87	10.00	●	●	●			●		●					●		●							
RCGN 191000		19.05	10.00	●	●	●			●		●					●		●							
RCGN 251200		25.40	12.70	●	●	●			●		●					●		●							

TURNING INSERT

SNGA

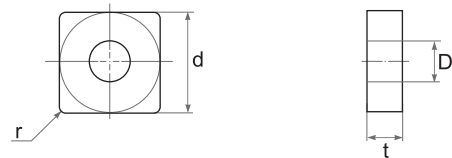
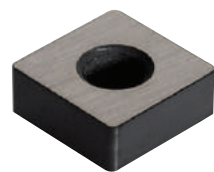

Type		Dimensions (mm)																									
ISO	ASA	d	t	r	D	ST100	ST300	ST500	ST900	SD200	SZ200	SZ300	SN26	SN300	SN400	SN500	SN600	SN800	SN950	SN1000	SW400	SW800	Coated ST	Coated SN	Coated SW		
SNGA 090304	SNGA 321	9.52	3.18	0.4	3.81	●	●																				
SNGA 090308	SNGA 322	9.52	3.18	0.8	3.81	●	●																				
SNGA 090312	SNGA 323	9.52	3.18	1.2	3.81	●	●																				
SNGA 090404	SNGA 331	9.52	4.76	0.4	3.81																						
SNGA 090408	SNGA 332	9.52	4.76	0.8	3.81																						
SNGA 090412	SNGA 333	9.52	4.76	1.2	3.81																						
SNGA 090416	SNGA 334	9.52	4.76	1.6	3.81										●												
SNGA 120404	SNGA 431	12.70	4.76	0.4	5.16	●		●		●			●	●								●	●				
SNGA 120408	SNGA 432	12.70	4.76	0.8	5.16	●	●	●		●			●	●	●							●	●				
SNGA 120412	SNGA 433	12.70	4.76	1.2	5.16	●	●	●		●	●		●	●	●							●	●				
SNGA 120416	SNGA 434	12.70	4.76	1.6	5.16	●				●			●	●								●	●				
SNGA 120708	SNGA 452	12.70	7.94	0.8	5.16	●																					
SNGA 120712	SNGA 453	12.70	7.94	1.2	5.16	●							●	●													
SNGA 120716	SNGA 454	12.70	7.94	1.6	5.16	●					●		●	●								●	●				
SNGA 150608	SNGA 542	15.87	6.35	0.8	6.35		●																				
SNGA 150612	SNGA 543	15.87	6.35	1.2	6.35	●	●																				
SNGA 150616	SNGA 544	15.87	6.35	1.6	6.35		●																				
SNGA 190612	SNGA 643	19.05	6.35	1.2	7.94	●																					
SNGA 190616	SNGA 644	19.05	6.35	1.6	7.94																						

SNMA

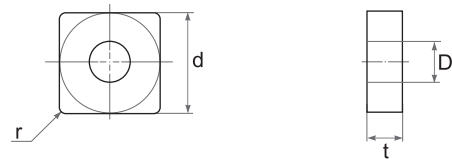
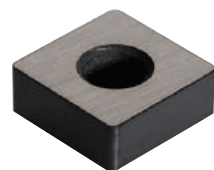

Type		Dimensions (mm)																									
ISO	ASA	d	t	r	D	ST100	ST300	ST500	ST900	SD200	SZ200	SZ300	SN26	SN300	SN400	SN500	SN600	SN800	SN950	SN1000	SW400	SW800	Coated ST	Coated SN	Coated SW		
SNMA 120408	SNMA 432	12.70	4.76	0.8	5.16										●												
SNMA 120412	SNMA 433	12.70	4.76	1.2	5.16										●	●			●		●						
SNMA 120416	SNMA 434	12.70	4.76	1.6	5.16										●	●											
SNMA 150616	SNMA 544	15.87	6.35	1.6	6.35										●	●											

TURNING INSERT

SNGN

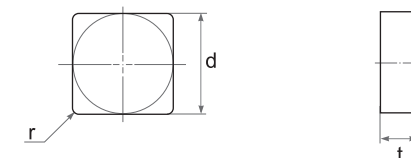

Type		Dimensions (mm)																									
ISO	ASA	d	t	r	ST100	ST300	ST500	ST900	SD200	SZ200	SZ300	SN26	SN300	SN400	SN500	SN600	SN800	SN950	SN1000	SW400	SW800	Coated ST	Coated SN	Coated SW			
SNGN 090304	SNGN 321	9.52	3.18	0.4	●	●																					
SNGN 090308	SNGN 322	9.52	3.18	0.8	●	●	●		●			●															
SNGN 090312	SNGN 323	9.52	3.18	1.2	●	●																					
SNGN 090404	SNGN 331	9.52	4.76	0.4																							
SNGN 090408	SNGN 332	9.52	4.76	0.8	●										●												
SNGN 090412	SNGN 333	9.52	4.76	1.2							●			●													
SNGN 120404	SNGN 431	12.70	4.76	0.4	●								●														
SNGN 120408	SNGN 432	12.70	4.76	0.8	●	●	●	●	●				●	●	●												
SNGN 120412	SNGN 433	12.70	4.76	1.2	●	●	●	●	●				●	●	●												
SNGN 120416	SNGN 434	12.70	4.76	1.6	●	●				●			●	●	●							●	●				
SNGN 120420	SNGN 435	12.70	4.76	2.0	●								●	●	●							●	●				
SNGN 120604	SNGN 441	12.70	6.35	0.4																							
SNGN 120608	SNGN 442	12.70	6.35	0.8	●																						
SNGN 120612	SNGN 443	12.70	6.35	1.2	●																						
SNGN 120616	SNGN 444	12.70	6.35	1.6	●																						
SNGN 120704	SNGN 451	12.70	7.94	0.4		●																					
SNGN 120708	SNGN 452	12.70	7.94	0.8	●	●	●	●	●				●	●	●							●	●	●	●	●	●
SNGN 120712	SNGN 453	12.70	7.94	1.2	●	●	●	●	●				●	●	●	●	●	●	●	●	●	●	●	●	●	●	●
SNGN 120716	SNGN 454	12.70	7.94	1.6	●	●	●	●	●				●	●	●	●	●	●	●	●	●	●	●	●	●	●	●
SNGN 120720	SNGN 455	12.70	7.94	2.0	●	●	●			●	●		●	●	●												
SNGN 150404	SNGN 531	15.87	4.76	0.4		●																					
SNGN 150408	SNGN 532	15.87	4.76	0.8		●																					
SNGN 150412	SNGN 533	15.87	4.76	1.2	●																						
SNGN 150416	SNGN 534	15.87	4.76	1.6	●																						
SNGN 150708	SNGN 552	15.87	7.94	0.8	●																						
SNGN 150712	SNGN 553	15.87	7.94	1.2	●	●																					
SNGN 150716	SNGN 554	15.87	7.94	1.6	●																						
SNGN 190608	SNGN 642	19.05	6.35	0.8																							
SNGN 190612	SNGN 643	19.05	6.35	1.2	●									●		●			●		●						
SNGN 190616	SNGN 644	19.05	6.35	1.6	●									●				●		●		●	●	●			
SNGN 190712	SNGN 653	19.05	7.94	1.2	●																						
SNGN 190716	SNGN 654	19.05	7.94	1.6	●	●	●	●	●				●									●					
SNGN 190720	SNGN 655	19.05	7.94	2.0	●									●													
SNGN 250720	SNGN 854	25.40	7.94	2.0	●									●													
SNGN 250724	SNGN 856	25.40	7.94	2.4	●	●								●	●												
SNGN 250924	SNGN 866	25.40	9.52	2.4	●		●	●		●			●	●	●							●			●		

TURNING INSERT

TURNING INSERT

SNGX

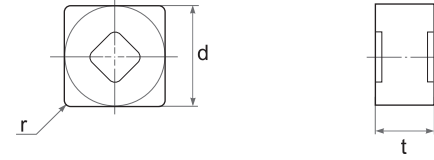

Type		Dimensions (mm)			ST100	ST300	ST500	ST900	SD200	SZ200	SZ300	SN26	SN300	SN400	SN500	SN600	SN800	SN950	SN1000	SW400	SW800	Coated ST	Coated SN	Coated SW	
ISO	ASA	d	t	r																					
SNGX 120408	SNGX 432	12.70	4.76	0.8										●											
SNGX 120412	SNGX 433	12.70	4.76	1.2										●											
SNGX 120416	SNGX 434	12.70	4.76	1.6										●											
SNGX 120708	SNGX 452	12.70	7.94	0.8	●								●		●										
SNGX 120712	SNGX 453	12.70	7.94	1.2	●	●							●	●	●		●		●						
SNGX 120716	SNGX 454	12.70	7.94	1.6									●	●	●	●	●		●						
SNGX 150708	SNGX 552	15.87	7.94	0.8	●	●							●		●										
SNGX 150712	SNGX 553	15.87	7.94	1.2	●	●							●		●		●								
SNGX 150716	SNGX 554	15.87	7.94	1.6									●	●	●				●						

SNMX

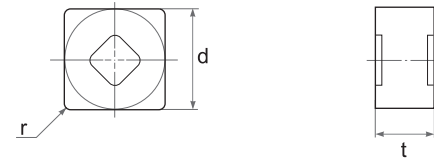

Type		Dimensions (mm)			ST100	ST300	ST500	ST900	SD200	SZ200	SZ300	SN26	SN300	SN400	SN500	SN600	SN800	SN950	SN1000	SW400	SW800	Coated ST	Coated SN	Coated SW	
ISO	ASA	d	t	r																					
SNMX 120712	SNMX 453	12.70	7.94	1.2									●	●	●	●	●		●						
SNMX 120716	SNMX 454	12.70	7.94	1.6										●											

SNMX .. RD

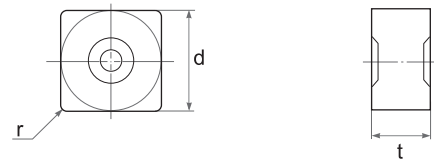

Type		Dimensions (mm)			0011S	0030S	0050S	0090S	002DS	002ZS	003ZS	SN26	SN300	SN400	SN500	SN600	SN800	SN950	SN1000	SW400	SW800	Coated ST	Coated SN	Coated SW	
ISO	ASA	d	t	r																					
SNMX 120716 RD	SNMX 454 RD	12.70	7.94	1.6									●		●										

TURNING INSERT

SCGN

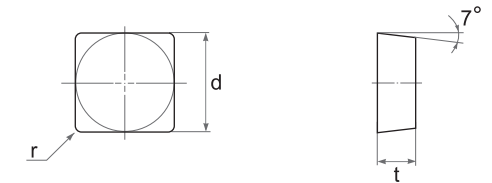

Type		Dimensions (mm)			ST100	ST300	ST500	ST900	SD200	SZ200	SZ300	SN26	SN300	SN400	SN500	SN600	SN800	SN950	SN1000	SW400	SW800	Coated ST	Coated SN	Coated SW	
ISO	ASA	d	t	r																					
SCGN 090412	SCGN 333	9.52	4.76	1.2	●									●											
SCGN 090416	SCGN 334	9.52	4.76	1.6	●																				
SCGN 120404	SCGN 431	12.70	4.76	0.4		●																			
SCGN 120408	SCGN 432	12.70	4.76	0.8	●	●																			
SCGN 120412	SCGN 433	12.70	4.76	1.2							●		●	●	●	●	●		●						
SCGN 120416	SCGN 434	12.70	4.76	1.6	●	●																			

SCGX

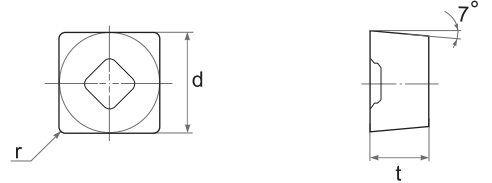

Type		Dimensions (mm)			ST100	ST300	ST500	ST900	SD200	SZ200	SZ300	SN26	SN300	SN400	SN500	SN600	SN800	SN950	SN1000	SW400	SW800	Coated ST	Coated SN	Coated SW	
ISO	ASA	d	t	r																					
SCGX 120616	SCGX 444	12.70	6.35	1.6													●								

SCGW

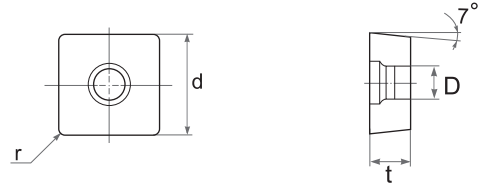

Type	Dimensions (mm)				ST100	ST300	ST500	ST900	SD200	SZ200	SZ300	SN26	SN300	SN400	SN500	SN600	SN800	SN950	SN1000	SW400	SW800	Coated ST	Coated SN	Coated SW
ISO	d	t	r	D																				
SCGW 09T304	9.52	3.97	0.4	4.40										●										
SCGW 09T308	9.52	3.97	0.8	4.40										●										
SCGW 120408	12.70	4.76	0.8	5.50										●										

TURNING INSERT

SPGN

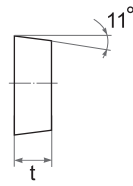
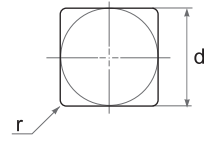

Type		Dimensions (mm)			ST100	ST300	ST500	ST900	SD200	SZ200	SZ300	SN26	SN300	SN400	SN500	SN600	SN800	SN950	SN1000	SW400	SW800	Coated ST	Coated SN	Coated SW	
ISO	ASA	d	t	r																					
SPGN 090304	SPGN 321	9.52	3.18	0.4	●	●						●													
SPGN 090308	SPGN 322	9.52	3.18	0.8	●	●		●				●	●	●						●	●				
SPGN 090312	SPGN 323	9.52	3.18	1.2	●																				
SPGN 120304	SPGN 421	12.70	3.18	0.4	●	●																			
SPGN 120308	SPGN 422	12.70	3.18	0.8	●	●	●		●		●	●	●												
SPGN 120312	SPGN 423	12.70	3.18	1.2	●	●			●		●	●	●	●											
SPGN 120404	SPGN 431	12.70	4.76	0.4																					
SPGN 120408	SPGN 432	12.70	4.76	0.8	●	●	●				●	●	●	●						●	●				
SPGN 120412	SPGN 433	12.70	4.76	1.2	●	●			●		●	●	●	●	●				●	●	●				
SPGN 120416	SPGN 434	12.70	4.76	1.6	●	●			●			●	●	●						●	●				
SPGN 150408	SPGN 532	15.87	4.76	0.8																					
SPGN 150412	SPGN 533	15.87	4.76	1.2		●						●													
SPGN 190412	SPGN 633	19.05	4.76	1.2	●																				
SPGN 190416	SPGN 634	19.05	4.76	1.6	●	●																			

SPGN .. CR

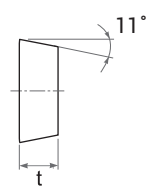
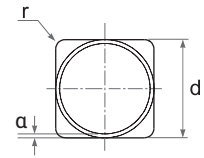
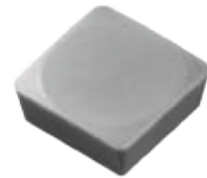

Type		Dimensions (mm)						ST100	ST300	ST500	ST900	SD200	SZ200	SZ300	SN26	SN300	SN400	SN500	SN600	SN800	SN950	SN1000	SW400	SW800	Coated ST	Coated SN	Coated SW
ISO	ASA	d	t	r	α	CR																					
SNHN 120412 CR05	SNHN 433 CR05	12.70	4.76	1.20	0.492	5°	●	●								●	●	●						●	●		

SNHN .. CR

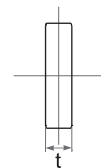
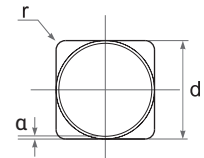
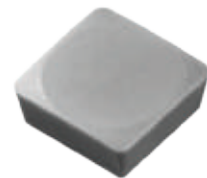

Type		Dimensions (mm)						ST100	ST300	ST500	ST900	SD200	SZ200	SZ300	SN26	SN300	SN400	SN500	SN600	SN800	SN950	SN1000	SW400	SW800	Coated ST	Coated SN	Coated SW
ISO	ASA	d	t	r	α	CR																					
SNHN 090412 CR10	SNHN 333 CR10	9.52	4.76	1.20	0.50	10°	●									●	●	●						●	●		
SNHN 120312 CR10	SNHN 423 CR10	12.70	3.18	1.20	0.50	10°																					
SNHN 120312 CR15	SNHN 423 CR10	12.70	3.18	1.20	0.50	15°																					
SNHN 120412 CR10	SNHN 433 CR10	12.70	4.76	1.20	0.50	10°																					
SNHN 120412 CR15	SNHN 433 CR10	12.70	4.76	1.20	0.50	15°																					

TURNING INSERT

TNGA

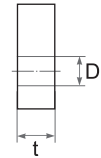
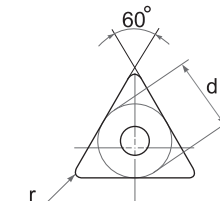
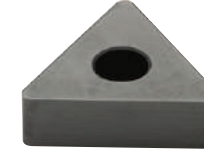

Type		Dimensions (mm)				ST100	ST300	ST500	ST900	SD200	SZ200	SZ300	SN26	SN300	SN400	SN500	SN600	SN800	SN950	SN1000	SW400	SW800	Coated ST	Coated SN	Coated SW
ISO	ASA	d	t	r	D																				
TNGA 110304	TNGA 221	6.35	3.18	0.4	2.26	●	●																		
TNGA 110308	TNGA 222	6.35	3.18	0.8	2.26	●	●																		
TNGA 160304	TNGA 321	9.52	3.18	0.4	3.81	●	●																		
TNGA 160308	TNGA 322	9.52	3.18	0.8	3.81	●	●			●			●												
TNGA 160312	TNGA 323	9.52	3.18	1.2	3.81	●	●																		
TNGA 160404	TNGA 331	9.52	4.76	0.4	3.81	●	●	●	●	●			●	●	●	●	●	●	●	●	●	●			
TNGA 160408	TNGA 332	9.52	4.76	0.8	3.81	●	●	●	●	●			●	●	●	●	●	●	●	●	●	●	●	●	
TNGA 160412	TNGA 333	9.52	4.76	1.2	3.81	●	●	●	●	●			●	●	●	●	●	●	●	●	●	●	●	●	
TNGA 160416	TNGA 334	9.52	4.76	1.6	3.81	●	●	●		●			●	●	●	●	●	●	●	●	●	●	●	●	
TNGA 220404	TNGA 431	12.70	4.76	0.4	5.16	●	●						●												
TNGA 220408	TNGA 432	12.70	4.76	0.8	5.16	●	●						●	●			●		●		●				
TNGA 220412	TNGA 433	12.70	4.76	1.2	5.16	●	●						●	●			●		●		●				
TNGA 220416	TNGA 434	12.70	4.76	1.6	5.16	●	●						●	●			●		●		●				
TNGA 220708	TNGA 452	12.70	7.94	0.8	5.16	●	●																		
TNGA 220712	TNGA 453	12.70	7.94	1.2	5.16	●																			
TNGA 270608	TNGA 542	15.87	6.35	0.8	6.35		●																		
TNGA 270612	TNGA 543	15.87	6.35	1.2	6.35		●																		
TNGA 330924	TNGA 666	19.05	9.52	2.4	7.94		●																		

TURNING INSERT

TNGN

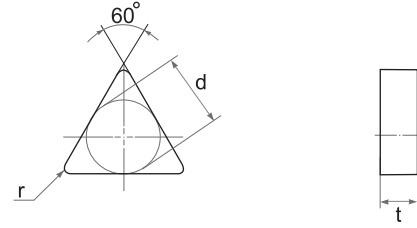

Type		Dimensions (mm)			ST100	ST300	ST500	ST900	SD200	SZ200	SZ300	SN26	SN300	SN400	SN500	SN600	SN800	SN950	SN1000	SW400	SW800	Coated ST	Coated SN	Coated SW
ISO	ASA	d	t	r																				
TNGN 110304	TNGN 221	6.35	3.18	0.4	●	●						●												
TNGN 110308	TNGN 222	6.35	3.18	0.8	●	●				●		●	●											
TNGN 160404	TNGN 331	9.52	4.76	0.4	●	●			●	●		●	●											
TNGN 160408	TNGN 332	9.52	4.76	0.8	●	●	●	●	●	●		●	●	●	●									
TNGN 160412	TNGN 333	9.52	4.76	1.2	●	●	●	●				●	●	●						●	●			
TNGN 160416	TNGN 334	9.52	4.76	1.6	●	●	●	●	●			●	●	●										
TNGN 160704	TNGN 351	9.52	7.94	0.4	●																			
TNGN 160708	TNGN 352	9.52	7.94	0.8	●	●			●			●												
TNGN 160712	TNGN 353	9.52	7.94	1.2	●	●				●		●	●											
TNGN 160716	TNGN 354	9.52	7.94	1.6	●	●						●												
TNGN 220404	TNGN 431	12.70	4.76	0.4	●																			
TNGN 220408	TNGN 432	12.70	4.76	0.8	●	●						●	●			●				●	●			
TNGN 220412	TNGN 433	12.70	4.76	1.2	●	●						●	●			●				●	●			
TNGN 220416	TNGN 434	12.70	4.76	1.6		●						●	●							●	●			
TNGN 220708	TNGN 452	12.70	7.94	0.8	●																			
TNGN 220712	TNGN 453	12.70	7.94	1.2		●																		
TNGN 220716	TNGN 454	12.70	7.94	1.6		●										●								
TNGN 270608	TNGN 542	15.87	6.35	0.8	●	●																		
TNGN 270612	TNGN 543	15.87	6.35	1.2	●	●																		
TNGN 270616	TNGN 544	15.87	6.35	1.6		●																		
TNGN 330924	TNGN 666	19.05	9.52	2.4		●																		
TNGN 440932	TNGN 868	25.40	9.52	3.2	●	●						●												

CERAMIC

CERMET

PCBN / PCD

TOOL HOLDER

MILLING CUTTER

TURNING INSERT

TCUN

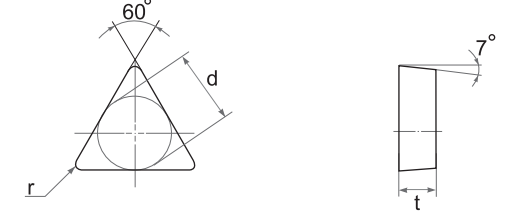

Type		Dimensions (mm)			ST100	ST300	ST500	ST900	SD200	SZ200	SZ300	SN26	SN300	SN400	SN500	SN600	SN800	SN950	SN1000	SW400	SW800	Coated ST	Coated SN	Coated SW
ISO	ASA	d	t	r																				
TCUN 160408	TCUN 332	9.52	4.76	0.8		●							●	●										
TCUN 160412	TCUN 333	9.52	4.76	1.2		●							●	●										
TCUN 160416	TCUN 334	9.52	4.76	1.6		●							●											

CERAMIC

CERMET

PCBN / PCD

TOOL HOLDER

MILLING CUTTER

TURNING INSERT

TPGN

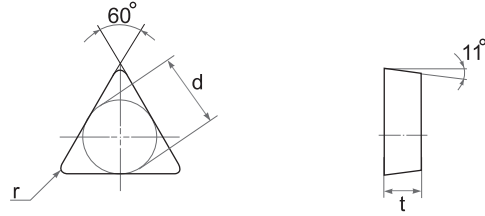
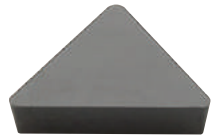

Type		Dimensions (mm)			ST100	ST300	ST500	ST900	SD200	SZ200	SZ300	SN26	SN300	SN400	SN500	SN600	SN800	SN950	SNT1000	SW400	SW800	Coated ST	Coated SN	Coated SW	
ISO	ASA	d	t	r																					
TPGN 090204	TPGN 731	5.56	2.38	0.4	●																				
TPGN 090208	TPGN 732	5.56	2.38	0.8	●																				
TPGN 110304	TPGN 221	6.35	3.18	0.4	●	●		●			●		●								●				
TPGN 110308	TPGN 222	6.35	3.18	0.8	●	●		●			●	●	●				●			●	●	●			
TPGN 160304	TPGN 321	9.52	3.18	0.4	●	●	●		●	●		●	●												
TPGN 160308	TPGN 322	9.52	3.18	0.8	●	●			●	●		●	●	●			●			●	●	●			
TPGN 160312	TPGN 323	9.52	3.18	1.2	●	●							●	●							●	●			
TPGN 160404	TPGN 331	9.52	4.76	0.4	●		●																		
TPGN 160408	TPGN 332	9.52	4.76	0.8	●	●											●			●					
TPGN 160412	TPGN 333	9.52	4.76	1.2	●												●			●					
TPGN 160416	TPGN 334	9.52	4.76	1.6	●																				
TPGN 220404	TPGN 431	12.70	4.76	0.4	●	●																			
TPGN 220408	TPGN 432	12.70	4.76	0.8	●	●					●									●	●				
TPGN 220412	TPGN 433	12.70	4.76	1.2	●	●						●	●												
TPGN 220416	TPGN 434	12.70	4.76	1.6	●	●	●																		
TPGN 220712	TPGN 453	12.70	7.94	1.2																					
TPGN 220716	TPGN 454	12.70	7.94	1.6																					
TPGN 271232	TPGN 588	15.87	12.70	3.2	●																				

TPUN

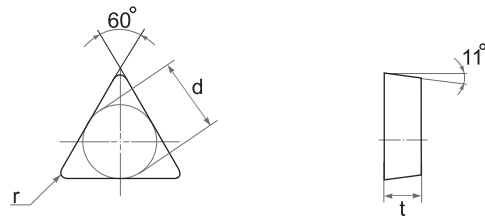
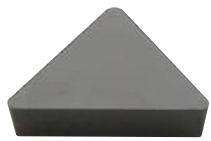

Type		Dimensions (mm)			ST100	ST300	ST500	ST900	SD200	SZ200	SZ300	SN26	SN300	SN400	SN500	SN600	SN800	SN950	SNT1000	SW400	SW800	Coated ST	Coated SN	Coated SW	
ISO	ASA	d	t	r																					
TPUN 110308	TPUN 222	6.35	3.18	0.8										●											
TPUN 110312	TPUN 223	6.35	3.18	1.2										●											

TURNING INSERT

VNGA

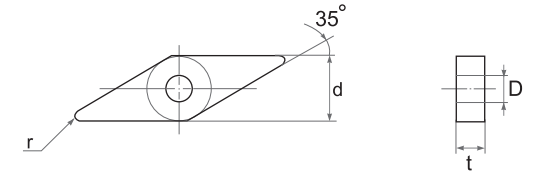
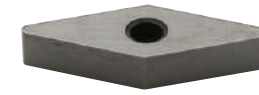

Type		Dimensions (mm)				ST100	ST300	ST500	ST900	SD200	SZ200	SZ300	SN26	SN300	SN400	SN500	SN600	SN800	SN950	SNT1000	SW400	SW800	Coated ST	Coated SN	Coated SW
ISO	ASA	d	t	r	D																				
VNGA 160404	VNGA 331	9.52	4.76	0.4	3.81	●	●	●					●												
VNGA 160408	VNGA 332	9.52	4.76	0.8	3.81	●	●	●	●				●	●	●	●		●		●					
VNGA 160412	VNGA 333	9.52	4.76	1.2	3.81	●	●	●	●				●	●	●	●									
VNGA 160604	VNGA 341	9.52	6.35	0.4	3.81	●	●																		
VNGA 160608	VNGA 342	9.52	6.35	0.8	3.81	●	●																		
VNGA 160612	VNGA 343	9.52	6.35	1.2	3.81	●	●																		
VNGA 220404	VNGA 431	12.70	4.76	0.4	5.16	●	●																		
VNGA 220408	VNGA 432	12.70	4.76	0.8	5.16	●	●								●										
VNGA 220412	VNGA 433	12.70	4.76	1.2	5.16	●	●								●										
VNGA 220424	VNGA 436	12.70	4.76	2.4	5.16																●	●			

VNGN

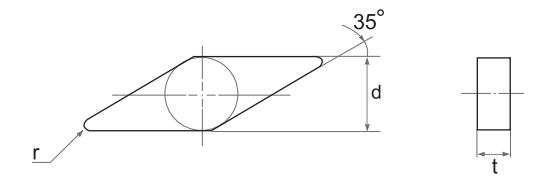

Type		Dimensions (mm)				ST100	ST300	ST500	ST900	SD200	SZ200	SZ300	SN26	SN300	SN400	SN500	SN600	SN800	SN950	SNT1000	SW400	SW800	Coated ST	Coated SN	Coated SW
ISO	ASA	d	t	r																					
VNGN 160404	VNGN 331	9.52	4.76	0.4		●																			
VNGN 160408	VNGN 332	9.52	4.76	0.8		●																			
VNGN 160704	VNGN 351	9.52	7.94	0.4		●																			
VNGN 160708	VNGN 352	9.52	7.94	0.8		●																			
VNGN 160712	VNGN 353	9.52	7.94	1.2																					
VNGN 160716	VNGN 354	9.52	7.94	1.6																					

TURNING INSERT

VNGX

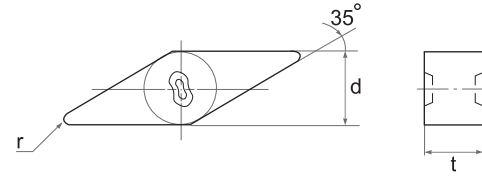

Type		Dimensions (mm)			ST100	ST300	ST500	ST900	SD200	SZ200	SZ300	SN26	SN300	SN400	SN500	SN600	SN800	SN950	SN1000	SW400	SW800	Coated ST	Coated SN	Coated SW	
ISO	ASA	d	t	r																					
VNGX 160708	VNGX 352	9.52	7.94	0.8	●					●				●											
VNGX 160712	VNGX 353	9.52	7.94	1.2	●					●				●	●										
VNGX 160716	VNGX 354	9.52	7.94	1.6										●											

TURNING INSERT

WNGA

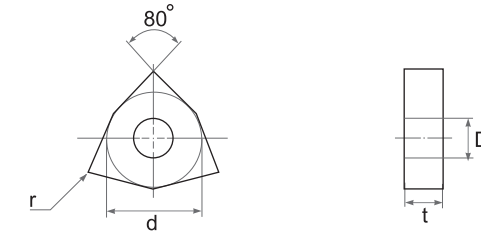
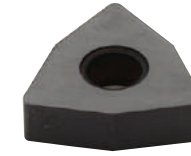

Type		Dimensions (mm)			ST100	ST300	ST500	ST900	SD200	SZ200	SZ300	SN26	SN300	SN400	SN500	SN600	SN800	SN950	SN1000	SW400	SW800	Coated ST	Coated SN	Coated SW	
ISO	ASA	d	t	r																					
WNGA 080404	WNGA 431	12.70	4.76	0.4	●	●																			
WNGA 080408	WNGA 432	12.70	4.76	0.8	●	●						●	●	●	●	●	●		●	●	●				
WNGA 080412	WNGA 433	12.70	4.76	1.2	●	●						●	●	●	●	●	●		●						

WNGX

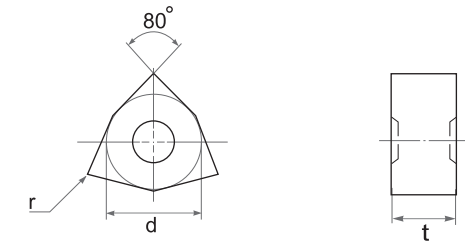

Type		Dimensions (mm)			ST100	ST300	ST500	ST900	SD200	SZ200	SZ300	SN26	SN300	SN400	SN500	SN600	SN800	SN950	SN1000	SW400	SW800	Coated ST	Coated SN	Coated SW	
ISO	ASA	d	t	r																					
WNGX 080708	WNGX 452	12.70	7.94	0.8										●											
WNGX 080712	WNGX 453	12.70	7.94	1.2								●		●	●	●	●		●						
WNGX 080716	WNGX 454	12.70	7.94	1.6										●											

ROLL TURNING INSERT

CDH

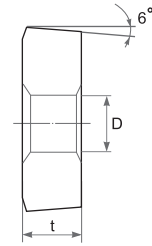
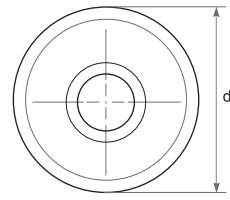

Type		Dimensions (mm)																							
ISO	ASA	d	t	D	ST100	ST300	ST500	ST900	SD200	SZ200	SZ300	SN26	SN300	SN400	SN500	SN600	SN800	SN950	SN1000	SW400	SW800	Coated ST	Coated SN	Coated SW	
CDH 120600	CDH 22	12.70	6.35	3.18	●	●	●																		
CDH 120900	CDH 23	12.70	9.52	3.18	●																				
CDH 190900	CDH 33	19.05	9.52	6.35	●	●	●	●				●													
CDH 191200	CDH 34	19.05	12.70	6.35	●																				
CDH 251200	CDH 42	25.40	12.70	6.75	●	●	●			●															
CDH 251900	CDH 43	25.40	19.05	6.75	●					●															
CDH 320900	CDH 515	31.75	9.52	10.00	●	●				●		●	●												
CDH 321900	CDH 53	31.75	19.05	10.00	●	●	●	●		●		●	●												
CDH 381100		38.10	11.11	9.93	●																				

ROLL TURNING INSERT

F-Series

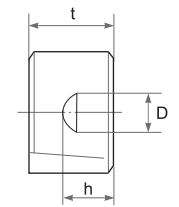
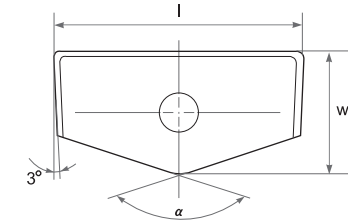

Type		Dimensions (mm)																										
ISO		l	w	t	D	h	α	ST100	ST300	ST500	ST900	SD200	SZ200	SZ300	SN26	SN300	SN400	SN500	SN600	SN800	SN950	SN1000	SW400	SW800	Coated ST	Coated SN	Coated SW	
F 13941		32.00	19.05	12.00	6.50	6.00	120°	●	●				●		●	●												
F 10537		44.50	25.40	14.20	6.50	7.00	120°	●	●				●		●	●												

F-Series

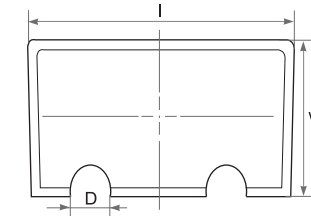
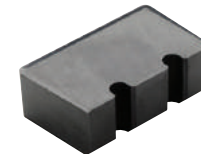

Type		Dimensions (mm)																								
ISO		l	w	t	D	ST100	ST300	ST500	ST900	SD200	SZ200	SZ300	SN26	SN300	SN400	SN500	SN600	SN800	SN950	SN1000	SW400	SW800	Coated ST	Coated SN	Coated SW	
F 10537 V		44.00	26.00	15.00	5.00	●	●				●															

F-Series

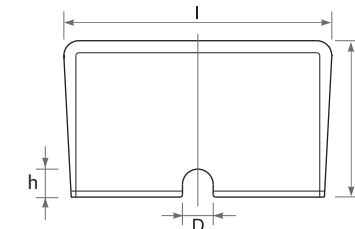

Type		Dimensions (mm)																								
ISO		l	w	t	D	h	ST100	ST300	ST500	ST900	SD200	SZ200	SZ300	SN26	SN300	SN400	SN500	SN600	SN800	SN950	SN1000	SW400	SW800	Coated ST	Coated SN	Coated SW
F 10537 S		44.55	26.00	15.00	5.10	4.60	●	●				●														

F-Series

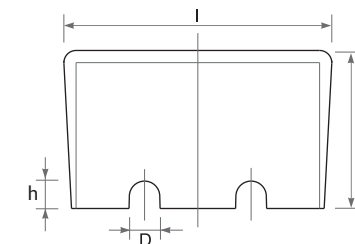
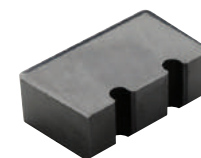

Type		Dimensions (mm)																								
ISO		l	w	t	D	h	ST100	ST300	ST500	ST900	SD200	SZ200	SZ300	SN26	SN300	SN400	SN500	SN600	SN800	SN950	SN1000	SW400	SW800	Coated ST	Coated SN	Coated SW
F 10537 VW		44.00	25.95	15.00	5.10	4.50	●	●				●														

ROLL TURNING INSERT

F-Series

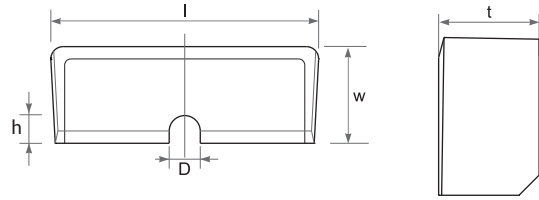

Type	Dimensions (mm)					ST100	ST300	ST500	ST900	SD200	SZ200	SZ300	SN26	SN300	SN400	SN500	SN600	SN800	SN950	SN1000	SW400	SW800	Coated ST	Coated SN	Coated SW
	ISO	l	w	t	D																				
F 431016 S	43.50	15.70	10.00	5.05	4.50	●	●				●														

F-Series

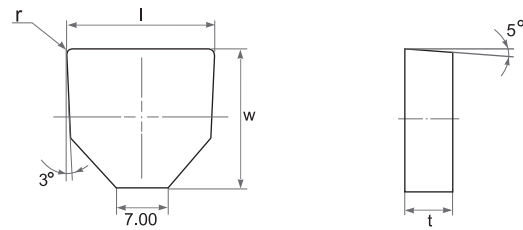
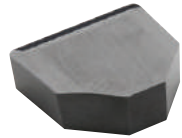

Type	Dimensions (mm)				ST100	ST300	ST500	ST900	SD200	SZ200	SZ300	SN26	SN300	SN400	SN500	SN600	SN800	SN950	SN1000	SW400	SW800	Coated ST	Coated SN	Coated SW
	ISO	l	t	r																				
F 250723	25.00	7.94	1.20	23.00	●																			

F-Series

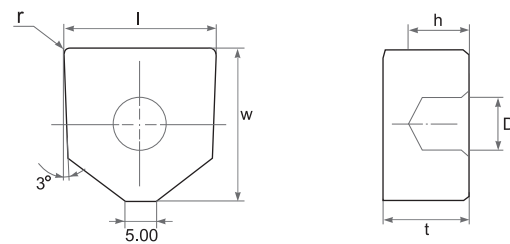

Type	Dimensions (mm)							ST100	ST300	ST500	ST900	SD200	SZ200	SZ300	SN26	SN300	SN400	SN500	SN600	SN800	SN950	SN1000	SW400	SW800	Coated ST	Coated SN	Coated SW
	ISO	l	t	r	w	D	h																				
F 251425	25.00	14.40	2.40	25.40	9.17	10.00									●												
F251425 H65	25.00	14.40	2.40	25.40	6.50	10.00								●													

ROLL TURNING INSERT

LNJ

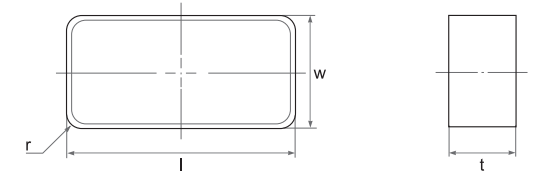

Type	Dimensions (mm)				ST100	ST300	ST500	ST900	SD200	SZ200	SZ300	SN26	SN300	SN400	SN500	SN600	SN800	SN950	SN1000	SW400	SW800	Coated ST	Coated SN	Coated SW	
	ISO	l	w	t																					r
LNJ 5464	25.40	15.87	9.52	1.6	●	●																			
LNJ 5568	31.75	15.87	9.52	3.2								●													
LNJ 6588	31.75	19.05	12.70	3.2	●	●	●	●		●		●	●												
LNJ 6688	38.10	19.05	12.70	3.2	●	●	●	●		●		●	●				●		●	●					
LNJ 6898	48.10	21.05	12.70	3.2								●													

SNGN3812R

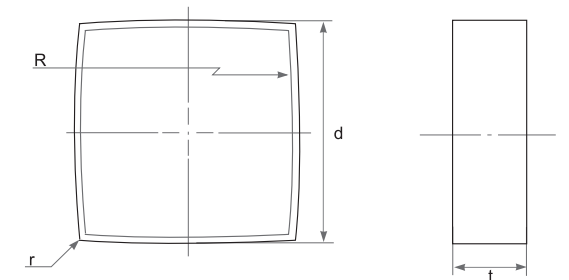

Type	Dimensions (mm)				ST100	ST300	ST500	ST900	SD200	SZ200	SZ300	SN26	SN300	SN400	SN500	SN600	SN800	SN950	SN1000	SW400	SW800	Coated ST	Coated SN	Coated SW
	ISO	d	t	R																				
SNGN 3812R	38.10	12.70	0.4	114	●	●	●																	

ROLL TURNING INSERT

RBGX

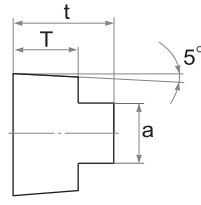
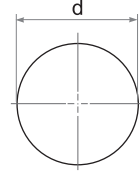

Type	Dimensions (mm)				ST100	ST300	ST500	ST900	SD200	SZ200	SZ300	SN26	SN300	SN400	SN500	SN600	SN800	SN950	SN1000	SW400	SW800	Coated ST	Coated SN	Coated SW
	ISO	d	t	T																				
RBGX 06T	6.00	5.00	3.00	3.00	●	●																		
RBGX 08T	8.00	6.50	4.00	4.00	●	●																		
RBGX 10T	10.00	9.00	6.00	6.00		●																		
RBGX 12T	12.00	9.00	6.00	6.00	●	●																		
RBGX 16T	16.00	13.00	8.00	8.00	●	●																		
RBGX 20T	20.00	15.00	10.00	10.00	●	●	●	●																
RBGX 26T	26.00	15.00	10.00	14.00	●	●																		

RCGX

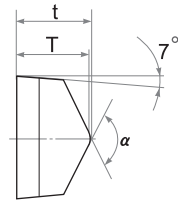
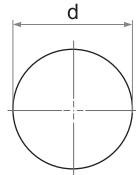

Type	Dimensions (mm)				ST100	ST300	ST500	ST900	SD200	SZ200	SZ300	SN26	SN300	SN400	SN500	SN600	SN800	SN950	SN1000	SW400	SW800	Coated ST	Coated SN	Coated SW
	ISO	ASA	d	t																				
RCGX 060400	RCGX 102	6.35	4.76	4.57	120°	●	●										●			●	●			
RCGX 060600	RCGX 102	6.35	6.35	6.20	120°	●	●	●	●								●			●	●			
RCGX 060700	RCGX 102	6.35	7.94	7.70	120°	●	●	●	●			●					●			●	●			
RCGX 090700	RCGX 103	9.52	7.94	7.70	120°	●	●	●	●			●					●			●	●			
RCGX 120700	RCGX 104	12.70	7.94	7.70	120°	●	●	●	●			●					●			●	●			
RCGX 151000	RCGX 105	15.87	10.00	9.77	120°	●	●	●	●			●					●			●	●			
RCGX 191000	RCGX 106	19.05	10.00	9.77	120°	●	●	●	●			●					●			●	●			
RCGX 251200	RCGX 108	25.40	12.00	11.85	140°	●	●	●	●			●					●			●	●			

ROLL TURNING INSERT

RPGX

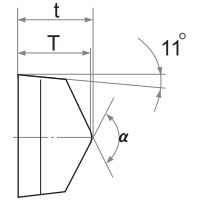
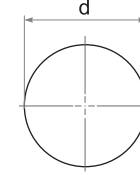

Type	Dimensions (mm)				ST100	ST300	ST500	ST900	SD200	SZ200	SZ300	SN26	SN300	SN400	SN500	SN600	SN800	SN950	SN1000	SW400	SW800	Coated ST	Coated SN	Coated SW
	ISO	ASA	d	t																				
RPGX 060400	RPGX 102	6.35	4.76	4.57	120°																●	●		
RPGX 090700	RPGX 103	9.52	7.94	7.70	120°																●	●	●	●
RPGX 120700	RPGX 104	12.70	7.94	7.70	120°																●	●	●	●

RXGX

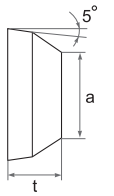
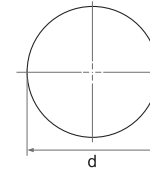

Type	Dimensions (mm)			ST100	ST300	ST500	ST900	SD200	SZ200	SZ300	SN26	SN300	SN400	SN500	SN600	SN800	SN950	SN1000	SW400	SW800	Coated ST	Coated SN	Coated SW	
	ISO	d	t																					a
RXGX 1207MO		12.00	7.94	6.90		●																		
RXGX 1608MO		16.00	8.00	9.50		●			●															
RXGX 2508MO		25.00	8.00	18.20	●				●															

GROOVING INSERT

SYBF

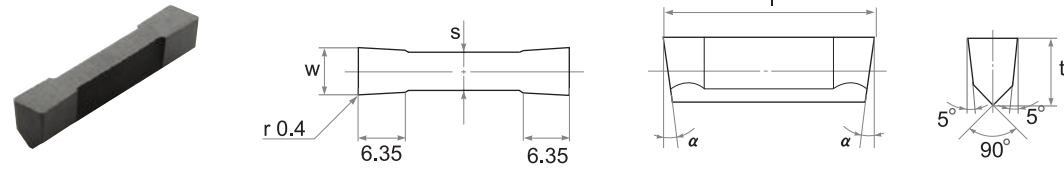

Type	Dimensions (mm)																										
	ISO	l	w	t	s	α	ST100	ST300	ST500	ST900	SD200	SZ200	SZ300	SN26	SN300	SN400	SN500	SN600	SN800	SN950	SN1000	SW400	SW800	Coated ST	Coated SN	Coated SW	
SYBF 3228	28.58	3.18	6.35	2.69	5.0°		●	●																			
SYBF 4828	28.58	4.78	6.35	3.66	5.0°		●	●																			
SYBF 5528	28.58	5.54	6.35	3.66	5.0°																						
SYBF 6428	28.58	6.35	8.56	5.13	7.0°		●	●																			
SYBF 7928	28.58	7.93	8.56	5.13	7.0°		●	●																			
SYBF 9528	28.58	9.53	8.56	6.99	7.0°																						

SYBF .. K

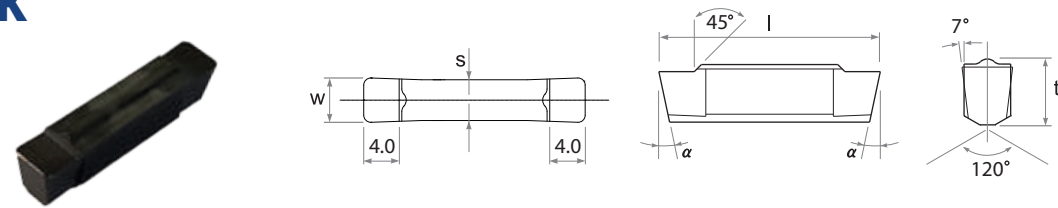

Type	Dimensions (mm)																										
	ISO	l	w	t	s	α	ST100	ST300	ST500	ST900	SD200	SZ200	SZ300	SN26	SN300	SN400	SN500	SN600	SN800	SN950	SN1000	SW400	SW800	Coated ST	Coated SN	Coated SW	
SYBF 5025K	25.00	5.00	6.50	4.60	12°											●		●									

SYBR

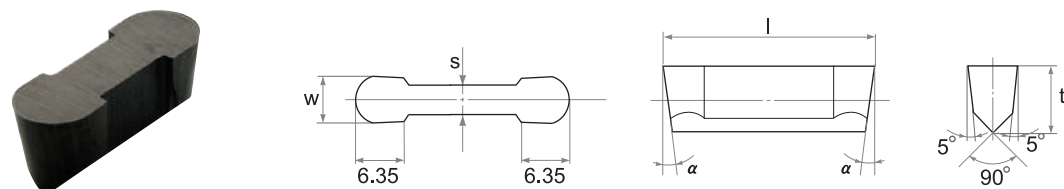

Type	Dimensions (mm)																										
	ISO	l	w	t	s	α	ST100	ST300	ST500	ST900	SD200	SZ200	SZ300	SN26	SN300	SN400	SN500	SN600	SN800	SN950	SN1000	SW400	SW800	Coated ST	Coated SN	Coated SW	
SYBR 3228	28.58	3.18	6.35	2.69	5.0°		●	●																			
SYBR 4828	28.58	4.78	6.35	3.66	5.0°		●	●																			
SYBR 5528	28.58	5.54	6.35	3.66	5.0°																						
SYBR 6428	28.58	6.35	8.56	5.13	7.0°		●	●																			
SYBR 7928	28.58	7.93	8.56	5.13	7.0°		●	●																			
SYBR 9528	28.58	9.53	8.56	6.99	7.0°																						

GROOVING INSERT

SGF



Type	Dimensions (mm)																									
	ISO	l	w	t	r	ST100	ST300	ST500	ST900	SD200	SZ200	SZ300	SN26	SN300	SN400	SN500	SN600	SN800	SN950	SN1000	SW400	SW800	Coated ST	Coated SN	Coated SW	
SGF 4012	12.00	4.00	5.00	0.50		●	●				●				●											
SGF 5012	12.00	5.00	5.00	0.80		●	●				●															
SGF 6015	15.00	6.00	7.50	0.80		●	●				●															
SGF 7015	15.00	7.00	7.50	0.80		●	●				●															
SGF 8015	15.00	8.00	7.50	0.80		●	●				●															
SGF 1015	15.00	10.00	7.50	0.80		●	●				●															

SGR

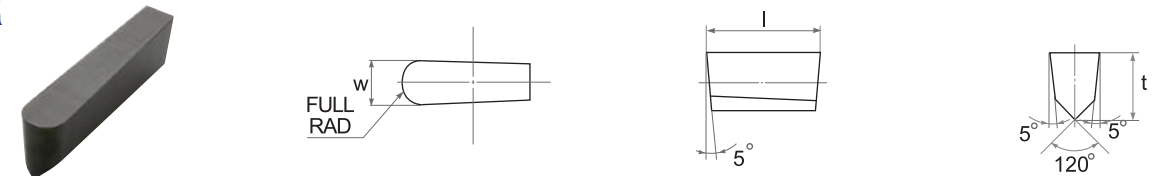

Type	Dimensions (mm)																								
	ISO	l	w	t	ST100	ST300	ST500	ST900	SD200	SZ200	SZ300	SN26	SN300	SN400	SN500	SN600	SN800	SN950	SN1000	SW400	SW800	Coated ST	Coated SN	Coated SW	
SGR 4012	12.00	4.00	5.00		●	●				●				●											
SGR 5012	12.00	5.00	5.00		●	●				●															
SGR 6015	15.00	6.00	7.50		●	●				●															
SGR 7015	15.00	7.00	7.50		●	●				●															
SGR 8015	15.00	8.00	7.50		●	●				●															
SGR 1015	15.00	10.00	7.50		●	●				●															

GROOVING INSERT

SSF

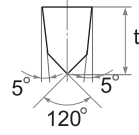
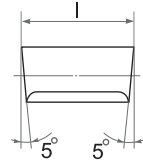
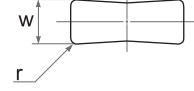

Type	Dimensions (mm)				ST100	ST300	ST500	ST900	SD200	SZ200	SZ300	SN26	SN300	SN400	SN500	SN600	SN800	SN950	SN1000	SW400	SW800	Coated ST	Coated SN	Coated SW	
	ISO	l	w	t																					r
SSF 4012	12.00	4.00	5.00	0.80	●	●				●															
SSF 5012	12.00	5.00	5.00	0.80	●	●				●															
SSF 6015	15.00	6.00	7.50	0.80	●	●				●															
SSF 7015	15.00	7.00	7.50	0.80	●	●																			
SSF 8015	15.00	8.00	7.50	0.80	●	●																			
SSF 1015	15.00	10.00	7.50	0.80	●	●																			

SSR

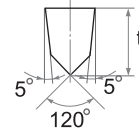
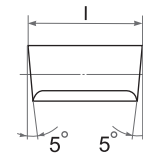
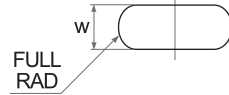

Type	Dimensions (mm)				ST100	ST300	ST500	ST900	SD200	SZ200	SZ300	SN26	SN300	SN400	SN500	SN600	SN800	SN950	SN1000	SW400	SW800	Coated ST	Coated SN	Coated SW	
	ISO	l	w	t																					
SSR 4012	12.00	4.00	5.00		●	●				●				●											
SSR 5012	12.00	5.00	5.00		●	●				●				●											
SSR 6015	15.00	6.00	7.50		●	●				●															
SSR 7015	15.00	7.00	7.50		●	●				●															
SSR 8015	15.00	8.00	7.50		●	●				●															
SSR 1015	15.00	10.00	7.50		●	●				●															

GROOVING INSERT

WFC

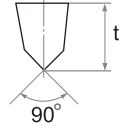
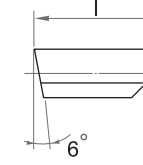
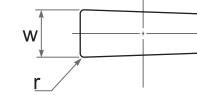

Type	Dimensions (mm)				ST100	ST300	ST500	ST900	SD200	SZ200	SZ300	SN26	SN300	SN400	SN500	SN600	SN800	SN950	SN1000	SW400	SW800	Coated ST	Coated SN	Coated SW	
	ISO	l	w	t																					r
WFC 094050-A	12.70	2.388	4.75	0.40																					
WFC 094050-B	12.70	2.388	4.75	0.80																					
WFC 125050-A	12.70	3.175	4.75	0.40																					
WFC 125050-B	12.70	3.175	4.75	0.80																					
WFC 156050-A	12.70	3.962	4.75	0.40																					
WFC 156050-B	12.70	3.962	4.75	0.80																					
WFC 187050-A	12.70	4.750	4.75	0.40																					
WFC 187050-B	12.70	4.750	4.75	0.80																					
WFC 218075-A	19.05	5.537	6.35	0.40																					
WFC 218075-B	19.05	5.537	6.35	0.80																					
WFC 250075-A	19.05	6.350	6.35	0.40																					
WFC 250075-B	19.05	6.350	6.35	0.80																					
WFC 250075-C	19.05	6.350	6.35	1.20																					
WFC 281075-A	19.05	7.137	6.35	0.40																					
WFC 281075-B	19.05	7.137	6.35	0.80																					
WFC 281075-C	19.05	7.137	6.35	1.20																					
WFC 312100-A	25.40	7.925	8.56	0.40																					
WFC 312100-B	25.40	7.925	8.56	0.80																					
WFC 312100-C	25.40	7.925	8.56	1.20																					
WFC 312100-D	25.40	7.925	8.56	1.60																					
WFC 344100-A	25.40	8.738	8.56	0.40																			●		
WFC 344100-B	25.40	8.738	8.56	0.80																					
WFC 344100-C	25.40	8.738	8.56	1.20																					
WFC 344100-D	25.40	8.738	8.56	1.60																					
WFC 375100-A	25.40	9.525	8.56	0.40																					
WFC 375100-B	25.40	9.525	8.56	0.80																					
WFC 375100-C	25.40	9.525	8.56	1.20																					
WFC 375100-D	25.40	9.525	8.56	1.60																			●		

*The above inserts WFC Series are available only Whisker grade.

GROOVING INSERT

WRC

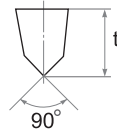
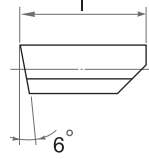
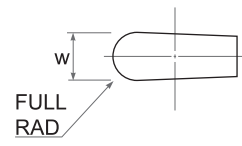

Type	Dimensions (mm)			ST100	ST300	ST500	ST900	SD200	SZ200	SZ300	SN26	SN300	SN400	SN500	SN600	SN800	SN950	SN1000	SW400	SW800	Coated ST	Coated SN	Coated SW	
	ISO	l	w																					t
WRC 094050	12.70	2.388	4.75																					
WRC 125050	12.70	3.175	4.75																					
WRC 156050	12.70	3.962	4.75																					
WRC 187050	12.70	4.750	4.75																					
WRC 218075	19.05	5.537	6.35																					
WRC 250075	19.05	6.350	6.35																					
WRC 281075	19.05	7.137	6.35																					
WRC 312100	25.40	7.925	8.56																					
WRC 344100	25.40	8.738	8.56																					
WRC 375100	25.40	9.525	8.56																					

*The above inserts WRC Series are available only Whisker grade.

GROOVING INSERT

WFP

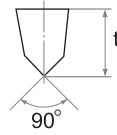
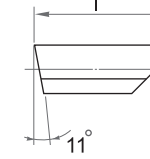
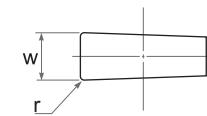

Type	Dimensions (mm)					ST100	ST300	ST500	ST900	SD200	SZ200	SZ300	SN26	SN300	SN400	SN500	SN600	SN800	SN950	SN1000	SW400	SW800	Coated ST	Coated SN	Coated SW	
	ISO	l	w	t	r																					
WFP 094050-A	12.70	2.388	4.75	0.40																						
WFP 094050-B	12.70	2.388	4.75	0.80																						
WFP 125050-A	12.70	3.175	4.75	0.40																						
WFP 125050-B	12.70	3.175	4.75	0.80																						
WFP 156050-A	12.70	3.962	4.75	0.40																						
WFP 156050-B	12.70	3.962	4.75	0.80																						
WFP 187050-A	12.70	4.750	4.75	0.40																						
WFP 187050-B	12.70	4.750	4.75	0.80																						
WFP 218075-A	19.05	5.537	6.35	0.40																						
WFP 218075-B	19.05	5.537	6.35	0.80																						
WFP 250075-A	19.05	6.350	6.35	0.40																						
WFP 250075-B	19.05	6.350	6.35	0.80																						
WFP 250075-C	19.05	6.350	6.35	1.20																						
WFP 281075-A	19.05	7.137	6.35	0.40																						
WFP 281075-B	19.05	7.137	6.35	0.80																						
WFP 281075-C	19.05	7.137	6.35	1.20																						
WFP 312100-A	25.40	7.925	8.56	0.40																						
WFP 312100-B	25.40	7.925	8.56	0.80																						
WFP 312100-C	25.40	7.925	8.56	1.20																						
WFP 312100-D	25.40	7.925	8.56	1.60																						
WFP 344100-A	25.40	8.738	8.56	0.40																						
WFP 344100-B	25.40	8.738	8.56	0.80																						
WFP 344100-C	25.40	8.738	8.56	1.20																						
WFP 344100-D	25.40	8.738	8.56	1.60																						
WFP 375100-A	25.40	9.525	8.56	0.40																						
WFP 375100-B	25.40	9.525	8.56	0.80																						
WFP 375100-C	25.40	9.525	8.56	1.20																						
WFP 375100-D	25.40	9.525	8.56	1.60																						

*The above inserts WFP Series are available only Whisker grade.

GROOVING INSERT

WRP

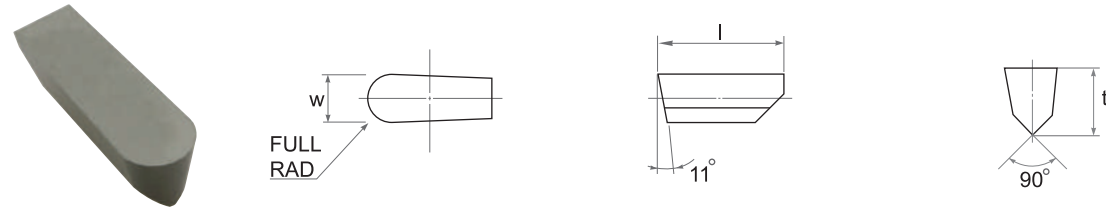

Type	Dimensions (mm)			ST100	ST300	ST500	ST900	SD200	SZ200	SZ300	SN26	SN300	SN400	SN500	SN600	SN800	SN950	SN1000	SW400	SW800	Coated ST	Coated SN	Coated SW	
	ISO	l	w																					t
WRP 094050	12.70	2.388	4.75																					
WRP 125050	12.70	3.175	4.75																		●			
WRP 156050	12.70	3.962	4.75																		●			
WRP 187050	12.70	4.750	4.75																		●			
WRP 218075	19.05	5.537	6.35																	●	●			
WRP 250075	19.05	6.350	6.35																	●	●			
WRP 281075	19.05	7.137	6.35																	●	●			
WRP 312100	25.40	7.925	8.56																	●	●			
WRP 344100	25.40	8.738	8.56																	●	●			
WRP 375100	25.40	9.525	8.56																	●	●			

*The above inserts WRP Series are available only Whisker grade.

GROOVING INSERT

SRG

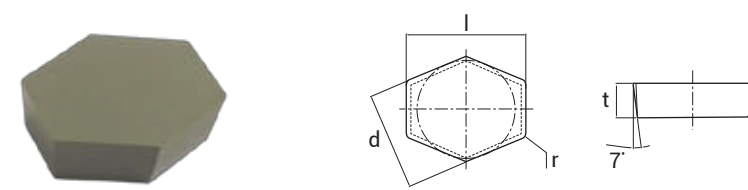

Type	Dimensions (mm)				ST100	ST300	ST500	ST900	SD200	SZ200	SZ300	SN26	SN300	SN400	SN500	SN600	SN800	SN950	SN1000	SW400	SW800	Coated ST	Coated SN	Coated SW	
	ISO	d	l	t																					r
SRG 1510	9.896	15.875	6.35	0.8																		●			
SRG 1512	12.206	15.875	6.35	0.8																		●			
SRG 1513	12.580	15.875	6.35	0.8																		●			
SRG 1914	14.370	19.050	6.35	0.8																		●			
SRG 1915	15.506	19.050	6.35	0.8																		●			

SRGA

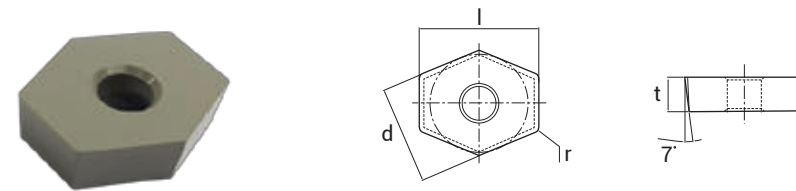

Type	Dimensions (mm)				ST100	ST300	ST500	ST900	SD200	SZ200	SZ300	SN26	SN300	SN400	SN500	SN600	SN800	SN950	SN1000	SW400	SW800	Coated ST	Coated SN	Coated SW	
	ISO	d	l	t																					r
SRGA 2216	16.741	22.200	6.35	0.8																		●			
SRGA 2218	18.300	22.225	6.35	0.8																		●			
SRGA 2522	22.700	25.700	7.94	0.8																		●			
SRGA 2518	17.802	25.400	6.35	0.8																		●			
SRGA 3819	19.630	38.100	6.35	0.8																		●			

MILLING INSERT

HNEN

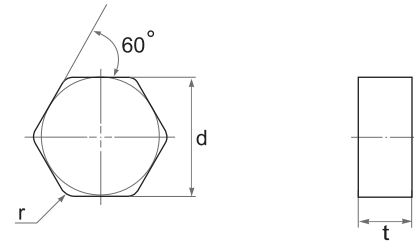

Type	Dimensions (mm)			ST100	ST300	ST500	ST900	SD200	SZ200	SZ300	SN26	SN300	SN400	SN500	SN600	SN800	SN950	SN1000	SW400	SW800	Coated ST	Coated SN	Coated SW	
	ISO	d	t																					r
HNEN 090520	16.20	5.56	2.0									●	●											
HNEN 090530	16.20	5.56	3.0									●	●											
HNEN 0905 ANSN	15.87	5.64	0.8									●	●	●										

LNE

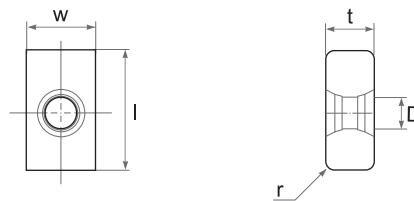

Type	Dimensions (mm)					ST100	ST300	ST500	ST900	SD200	SZ200	SZ300	SN26	SN300	SN400	SN500	SN600	SN800	SN950	SN1000	SW400	SW800	Coated ST	Coated SN	Coated SW
	ISO	l	w	t	D																				
LNE 040904	15.87	9.52	4.76	4.41	0.4									●	●										
LNE 040908	15.87	9.52	4.76	4.41	0.8									●	●										
LNE 040912	15.87	9.52	4.76	4.41	1.2									●	●										
LNE 1007	15.67	9.52	6.35	4.10	1.2									●	●										

MILLING INSERT

OEGB

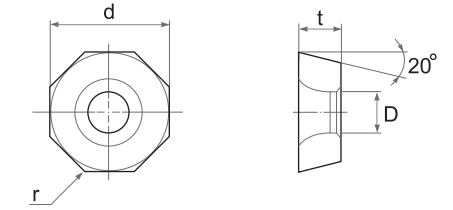

Type	Dimensions (mm)				ST100	ST300	ST500	ST900	SD200	SZ200	SZ300	SN26	SN300	SN400	SN500	SN600	SN800	SN950	SN1000	SW400	SW800	Coated ST	Coated SN	Coated SW
	ISO	d	t	D																				
OEGB 070408	15.87	4.76	5.18	0.8									●											
OEGB 070416	15.87	4.76	5.18	1.6									●	●	●									

OEGB .. CR

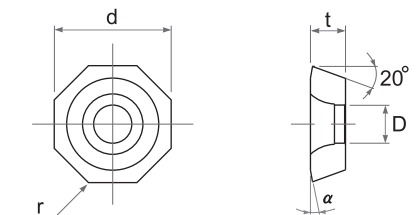

Type	Dimensions (mm)					ST100	ST300	ST500	ST900	SD200	SZ200	SZ300	SN26	SN300	SN400	SN500	SN600	SN800	SN950	SN1000	SW400	SW800	Coated ST	Coated SN	Coated SW
	ISO	d	t	D	r																				
OEGB 070408 0003 CR	15.87	4.76	5.18	0.80	10°									●	●										
OEGB 070416 0003 CR	15.87	4.76	5.18	1.60	10°									●	●										
OEGB 070516 0003 CR	15.87	5.56	5.18	1.60	10°									●	●										

OPEN

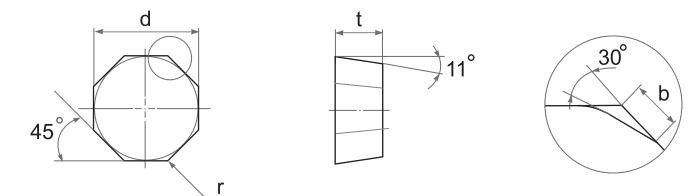

Type	Dimensions (mm)				ST100	ST300	ST500	ST900	SD200	SZ200	SZ300	SN26	SN300	SN400	SN500	SN600	SN800	SN950	SN1000	SW400	SW800	Coated ST	Coated SN	Coated SW
	ISO	d	t	r																				
OPEN 050408 TR	13.97	4.76	0.80	2.10									●											
OPEN 050608 TR	13.97	6.35	0.80	2.10									●		●									

MILLING INSERT

SNCN

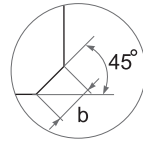
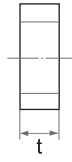
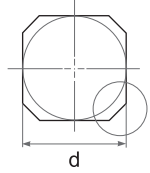

Type		Dimensions (mm)			ST100	ST300	ST500	ST900	SD200	SZ200	SZ300	SN26	SN300	SN400	SN500	SN600	SN800	SN950	SN1000	SW400	SW800	Coated ST	Coated SN	Coated SW		
ISO	ASA	d	t	b																						
SNCN 1204 AN	SNCN 43 AN	12.70	4.76	2.50										●												
SNCN 1204 ZN	SNCN 43 ZN	12.70	4.76	1.10										●												

SNCN .. ENTN

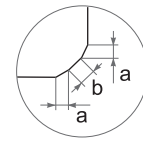
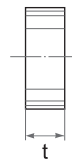
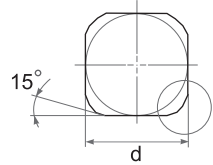

Type		Dimensions (mm)				ST100	ST300	ST500	ST900	SD200	SZ200	SZ300	SN26	SN300	SN400	SN500	SN600	SN800	SN950	SN1000	SW400	SW800	Coated ST	Coated SN	Coated SW	
ISO	ASA	d	t	a	b																					
SNCN 1204 ENTN	SNCN 43 ENTN	12.70	4.76	1.40	1.00								●	●	●											
SNCN 1504 ENTN	SNCN 53 ENTN	15.87	4.76	1.40	1.00								●	●	●											

SNGN .. ING

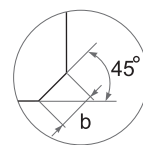
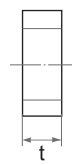
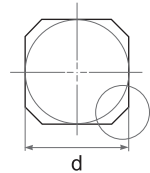

Type		Dimensions (mm)			ST100	ST300	ST500	ST900	SD200	SZ200	SZ300	SN26	SN300	SN400	SN500	SN600	SN800	SN950	SN1000	SW400	SW800	Coated ST	Coated SN	Coated SW	
ISO	ASA	d	t	b																					
SNGN 1204 ING	SNGN 43 ING	12.70	4.76	1.50									●	●											
SNGN 1904 ING	SNGN 63 ING	19.05	4.76	2.50									●	●											

MILLING INSERT

SDCN

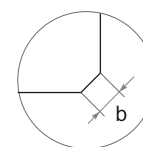
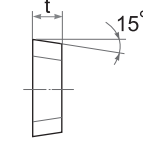
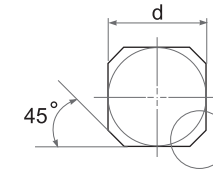

Type		Dimensions (mm)			ST100	ST300	ST500	ST900	SD200	SZ200	SZ300	SN26	SN300	SN400	SN500	SN600	SN800	SN950	SN1000	SW400	SW800	Coated ST	Coated SN	Coated SW	
ISO	ASA	d	t	b																					
SDCN 1203 AETN 12	SDCN 42 AETN 12	12.70	3.18	1.2									●												
SDCN 1203 AETN	SDCN 42 AETN	12.70	3.18	2.0									●												
SDCN 1504 AETN	SDCN 53 AETN	15.87	4.76	2.0																					

SDCN .. T

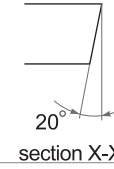
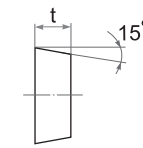
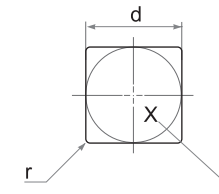

Type		Dimensions (mm)				ST100	ST300	ST500	ST900	SD200	SZ200	SZ300	SN26	SN300	SN400	SN500	SN600	SN800	SN950	SN1000	SW400	SW800	Coated ST	Coated SN	Coated SW
ISO	ASA	d	t	r																					
SDCN 120408 T20	SDCN 432 T20	12.70	4.76	0.8										●											
SDCN 120412 T20	SDCN 433 T20	12.70	4.76	1.2										●											

SDCW

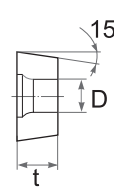
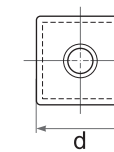

Type		Dimensions (mm)			ST100	ST300	ST500	ST900	SD200	SZ200	SZ300	SN26	SN300	SN400	SN500	SN600	SN800	SN950	SN1000	SW400	SW800	Coated ST	Coated SN	Coated SW	
ISO	ASA	d	t	D																					
SDCW 1204 PDSR	SDCW 43 PDSR	12.70	4.76	4.40									●		●										

MILLING INSERT

SEAN

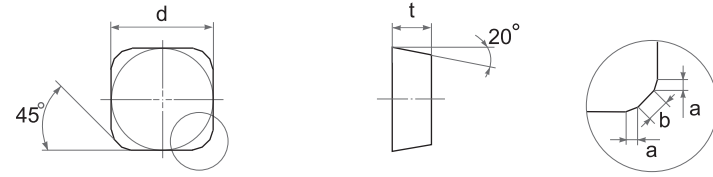

Type		Dimensions (mm)																								
ISO	ASA	d	t	a	b	ST100	ST300	ST500	ST900	SD200	SZ200	SZ300	SN26	SN300	SN400	SN500	SN600	SN800	SN950	SNT1000	SW400	SW800	Coated ST	Coated SN	Coated SW	
SEAN 1203 AFTN	SEAN 42 AFTN	12.70	3.18	0.50	1.80								●	●	●											
SEAN 1504 AFTN	SEAN 53 AFTN	12.70	4.76	0.70	2.00								●	●	●											

SEAN .. NW

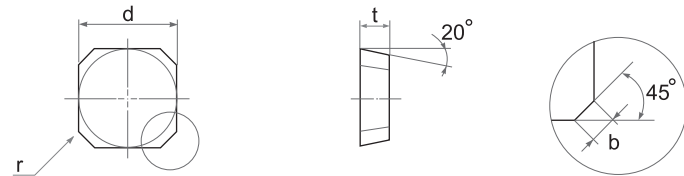

Type		Dimensions (mm)																								
ISO	ASA	d	t	b	r	ST100	ST300	ST500	ST900	SD200	SZ200	SZ300	SN26	SN300	SN400	SN500	SN600	SN800	SN950	SNT1000	SW400	SW800	Coated ST	Coated SN	Coated SW	
SEAN 1203 NWAFTN	SEAN 42 NWAFTN	12.70	3.18	2.40	0.4								●													
SEAN 1204 AFTNW25	SEAN 43 AFTNW25	12.70	4.76	2.50	1.2										●											

SEAN .. T

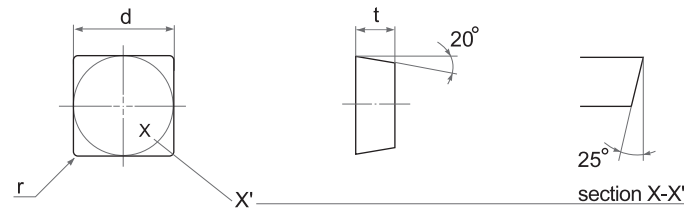

Type		Dimensions (mm)																								
ISO	ASA	d	t	a	b	ST100	ST300	ST500	ST900	SD200	SZ200	SZ300	SN26	SN300	SN400	SN500	SN600	SN800	SN950	SNT1000	SW400	SW800	Coated ST	Coated SN	Coated SW	
SEAN 120412 T25	SEAN 433 T25	12.70	4.76	1.2											●				●							
SEAN 120416 T25	SEAN 434 T25	12.70	4.76	1.6											●				●							

MILLING INSERT

SPCN .. T

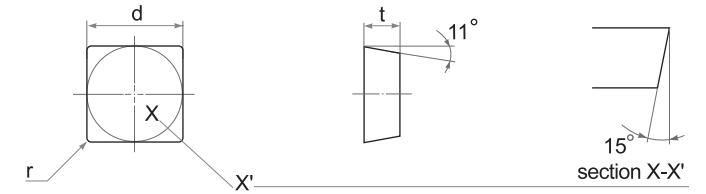
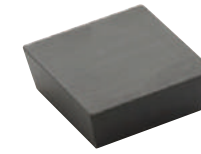

Type		Dimensions (mm)																							
ISO	ASA	d	t	r	ST100	ST300	ST500	ST900	SD200	SZ200	SZ300	SN26	SN300	SN400	SN500	SN600	SN800	SN950	SNT1000	SW400	SW800	Coated ST	Coated SN	Coated SW	
SPCN 120412 T15	SPCN 433 T15	12.70	4.76	1.2										●											
SPCN 120416 T15	SPCN 434 T15	12.70	4.76	1.6										●											

SPCW



Type		Dimensions (mm)																							
ISO	ASA	d	t	D	ST100	ST300	ST500	ST900	SD200	SZ200	SZ300	SN26	SN300	SN400	SN500	SN600	SN800	SN950	SNT1000	SW400	SW800	Coated ST	Coated SN	Coated SW	
SPCW 10T3ZX	SPCW 10T3ZX	10.00	3.97	3.52										●											

SPEN

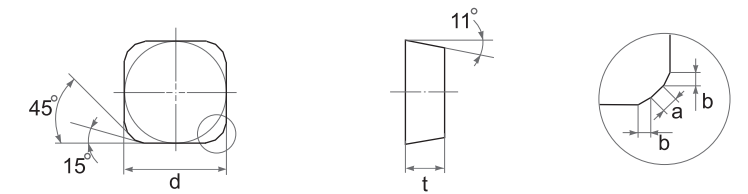

Type		Dimensions (mm)																							
ISO	ASA	d	t	a	b	ST100	ST300	ST500	ST900	SD200	SZ200	SZ300	SN26	SN300	SN400	SN500	SN600	SN800	SN950	SNT1000	SW400	SW800	Coated ST	Coated SN	Coated SW
SPEN 1206 APTN	SPEN 44 APTN	12.70	6.35	1.20	1.20										●		●								

MILLING INSERT

SPHX

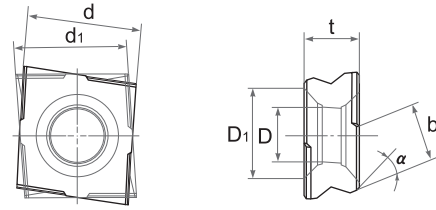

Type		Dimensions (mm)						ST100	ST300	ST500	ST900	SD200	SZ200	SZ300	SN26	SN300	SN400	SN500	SN600	SN800	SN950	SN1000	SW400	SW800	Coated ST	Coated SN	Coated SW
ISO	ASA	d	d ₁	t	D	D ₁	a	b																			
SPHX 1205NR 480T		11.67	11.33	5.50	5.10	8.41	45	8.0									●	●									
SPHX 1205NL 480T		11.67	11.33	5.50	5.10	8.41	45	8.0																			
SPHX 1205ER 855T		12.09	11.33	5.50	5.10	8.41	35	5.50									●	●									
SPHX 1205EL 855T		12.09	11.33	5.50	5.10	8.41	35	5.50									●	●									
SPHX 15T6NR 880T		14.58	14.33	6.60	6.10	10.18	45	8.80									●	●									
SPHX 15T6ER 865T		15.50	14.33	6.60	6.10	10.18	35	6.50									●	●									

SPKN

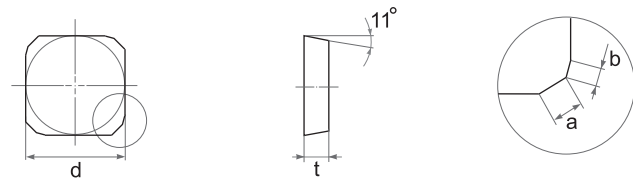

Type		Dimensions (mm)				ST100	ST300	ST500	ST900	SD200	SZ200	SZ300	SN26	SN300	SN400	SN500	SN600	SN800	SN950	SN1000	SW400	SW800	Coated ST	Coated SN	Coated SW
ISO	ASA	d	t	a	b																				
SPKN 1203 EDTR	SPKN 42 EDTR	12.70	3.18	1.40	1.00											●									
SPKN 1504 EDTR	SPKN 53 EDTR	15.87	4.76	1.40	1.00											●	●								

SPKN .. SP

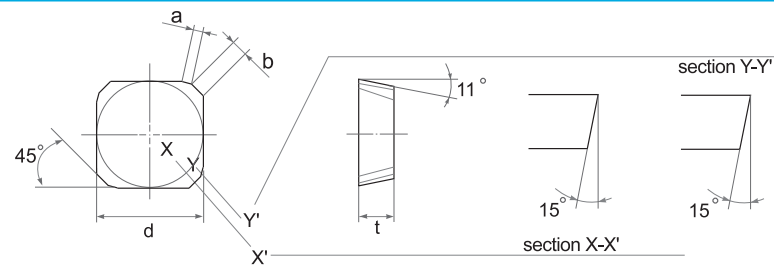

Type		Dimensions (mm)				ST100	ST300	ST500	ST900	SD200	SD225	SD275	SN26	SN300	SN400	SN500	SN600	SN800	SN950	SN1000	SW400	SW800	Coated ST	Coated SN	Coated SW
ISO	ASA	d	t	a	b																				
SPKN 1204SP EDTR	SPKN 43SP EDTR	12.70	4.76	1.10	1.30											●									

MILLING INSERT

TNCN

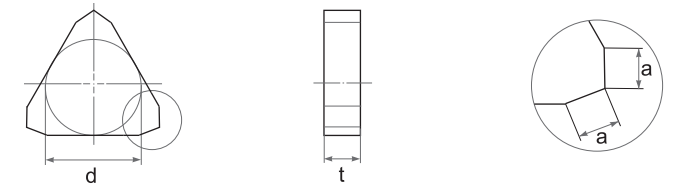

Type		Dimensions (mm)			ST100	ST300	ST500	ST900	SD200	SZ200	SZ300	SN26	SN300	SN400	SN500	SN600	SN800	SN950	SN1000	SW400	SW800	Coated ST	Coated SN	Coated SW	
ISO	ASA	d	t	a																					
TNCN 2204 ANT	TNCN 43 ANT	12.70	4.76	2.60									●	●											

TEKN

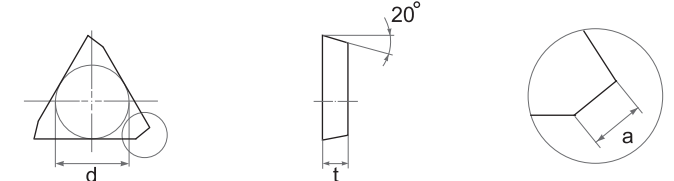
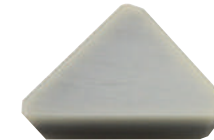

Type		Dimensions (mm)			ST100	ST300	ST500	ST900	SD200	SZ200	SZ300	SN26	SN300	SN400	SN500	SN600	SN800	SN950	SN1000	SW400	SW800	Coated ST	Coated SN	Coated SW
ISO	ASA	d	t	a																				
TEKN 1603 PFTR	TEKN 32 PFTR	9.52	3.18	1.40									●	●										
TEKN 2204 PFTR	TEKN 43 PFTR	12.70	4.76	2.10									●	●										

TPKN

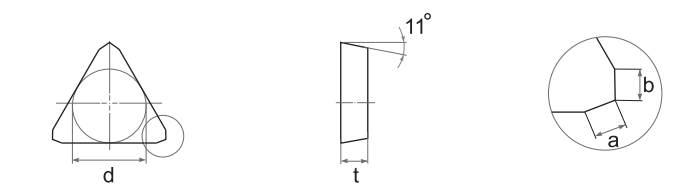
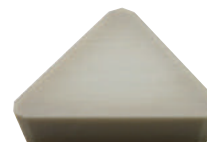

Type		Dimensions (mm)				ST100	ST300	ST500	ST900	SD200	SZ200	SZ300	SN26	SN300	SN400	SN500	SN600	SN800	SN950	SN1000	SW400	SW800	Coated ST	Coated SN	Coated SW
ISO	ASA	d	t	a	b																				
TPKN 1603 PDTR	TPKN 32 PDTR	9.52	3.18	1.20	1.00									●	●										
TPKN 2204 PDTR	TPKN 43 PDTR	12.70	4.76	1.40	0.70									●	●										

WIPER INSERT

CNGN .. AZ

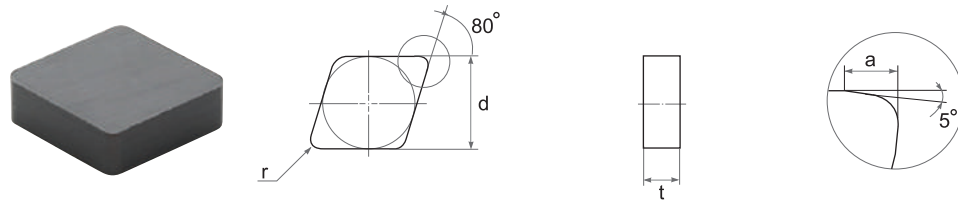

Type		Dimensions (mm)																								
ISO	ASA	d	t	r	a	ST100	ST300	ST500	ST900	SD200	SZ200	SZ300	SN26	SN300	SN400	SN500	SN600	SN800	SN950	SNT1000	SW400	SW800	Coated ST	Coated SN	Coated SW	
CNGN 1204 AZ	CNGN 43 AZ	12.70	4.76	1.0	1.60	●									●											

ADVANTAGE OF WIPER INSERT

f : feed (mm)
r : corner radius
r_w : wiper radius (large radius)
R_a : surface finish

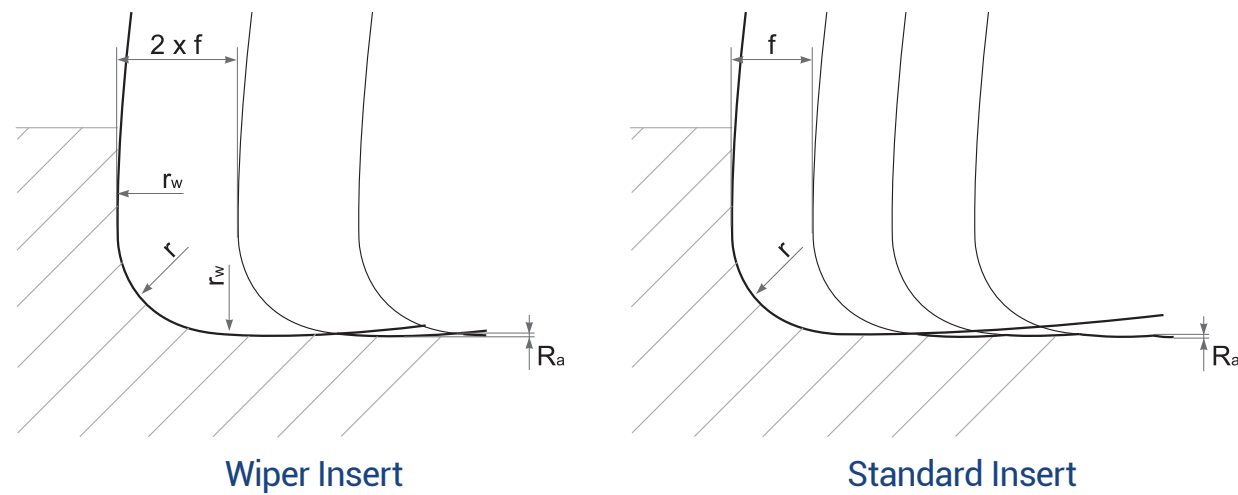

Wiper Insert

Standard Insert

WIPER INSERT

SNCN .. ZYT

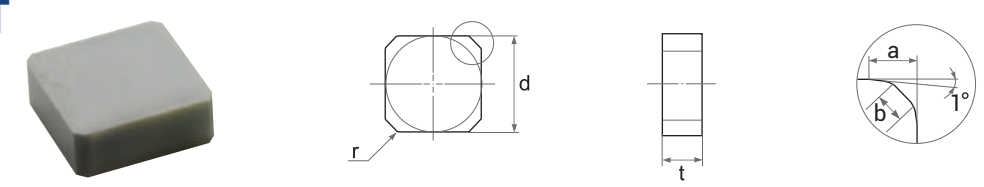

Type		Dimensions (mm)																								
ISO	ASA	d	t	a	b	ST100	ST300	ST500	ST900	SD200	SZ200	SZ300	SN26	SN300	SN400	SN500	SN600	SN800	SN950	SNT1000	SW400	SW800	Coated ST	Coated SN	Coated SW	
SNCN 0904 ZYT	SNCN 33 ZYT	9.52	4.76	1.30	1.10										●	●										
SNCN 1204 ZYT	SNCN 43 ZYT	12.70	4.76	3.25	1.10	●									●	●										

SNCN .. GZ

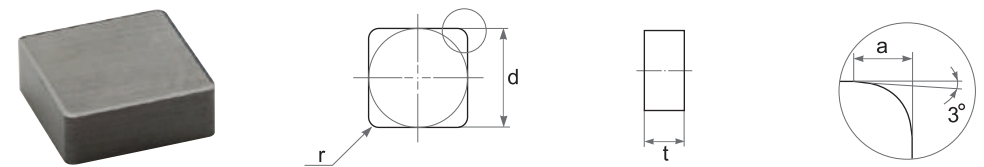

Type		Dimensions (mm)																								
ISO	ASA	d	t	a	b	ST100	ST300	ST500	ST900	SD200	SZ200	SZ300	SN26	SN300	SN400	SN500	SN600	SN800	SN950	SNT1000	SW400	SW800	Coated ST	Coated SN	Coated SW	
SNCN 0904 GZ	SNCN 33 GZ	9.52	4.76	0.8	1.00										●											

SNCN .. KZ

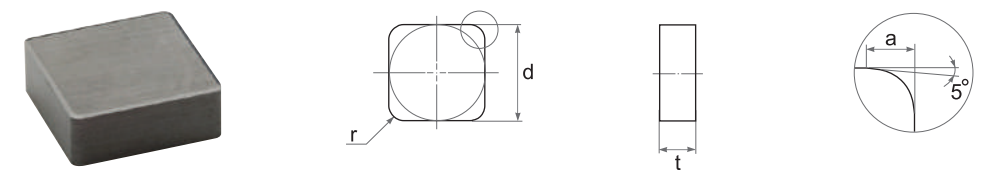

Type		Dimensions (mm)																								
ISO	ASA	d	t	a	b	ST100	ST300	ST500	ST900	SD200	SZ200	SZ300	SN26	SN300	SN400	SN500	SN600	SN800	SN950	SNT1000	SW400	SW800	Coated ST	Coated SN	Coated SW	
SNCN 1204 KZ	SNCN 43 KZ	12.70	4.76	1.2	1.80										●											

WIPER INSERT

SCGN .. WZ

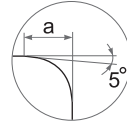
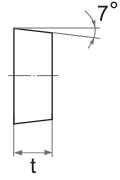
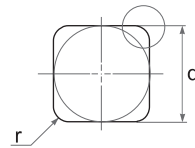

Type		Dimensions (mm)				ST100	ST300	ST500	ST900	SD200	SZ200	SZ300	SN26	SN300	SN400	SN500	SN600	SN800	SN950	SNT1000	SW400	SW800	Coated ST	Coated SN	Coated SW
ISO	ASA	d	t	a	b																				
SCGN 0904 WZ	SCGN 33 WZ	9.52	4.76	0.8	1.60									●											
SCGN 1204 WZ	SCGN 43 WZ	12.70	4.76	0.8	1.60									●											

SCGN .. XZ

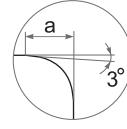
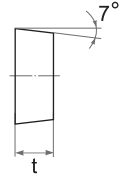
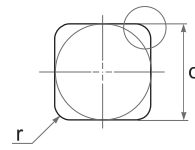
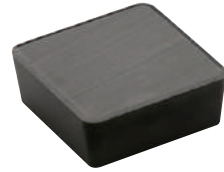

Type		Dimensions (mm)				ST100	ST300	ST500	ST900	SD200	SZ200	SZ300	SN26	SN300	SN400	SN500	SN600	SN800	SN950	SNT1000	SW400	SW800	Coated ST	Coated SN	Coated SW
ISO	ASA	d	t	a	b																				
SCGN 0904 XZ	SCGN 33 XZ	9.52	4.76	0.8	1.20									●											
SCGN 1204 XZ	SCGN 43 XZ	12.70	4.76	0.8	1.20									●											

SCGN .. ZZ

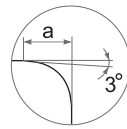
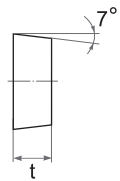
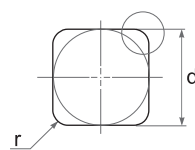

Type		Dimensions (mm)				ST100	ST300	ST500	ST900	SD200	SZ200	SZ300	SN26	SN300	SN400	SN500	SN600	SN800	SN950	SNT1000	SW400	SW800	Coated ST	Coated SN	Coated SW
ISO	ASA	d	t	a	b																				
SCGN 0904 ZZ	SCGN 33 ZZ	9.52	4.76	0.8	1.00									●											
SCGN 1204 ZZ	SCGN 43 ZZ	12.70	4.76	0.8	1.00									●											

WIPER INSERT

SCGN .. MZ

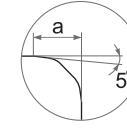
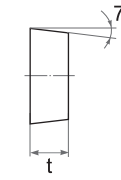
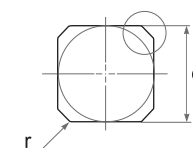

Type		Dimensions (mm)				ST100	ST300	ST500	ST900	SD200	SZ200	SZ300	SN26	SN300	SN400	SN500	SN600	SN800	SN950	SNT1000	SW400	SW800	Coated ST	Coated SN	Coated SW
ISO	ASA	d	t	a	b																				
SCGN 0904 MZ	SCGN 33 MZ	9.52	4.76	0.8	1.80									●											
SCGN 1204 MZ	SCGN 43 MZ	12.70	4.76	0.8	1.80									●											

SCGN .. ZM

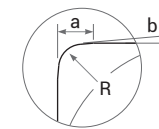
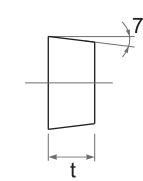
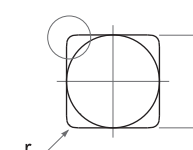

Type		Dimensions (mm)					ST100	ST300	ST500	ST900	SD200	SZ200	SZ300	SN26	SN300	SN400	SN500	SN600	SN800	SN950	SNT1000	SW400	SW800	Coated ST	Coated SN	Coated SW
ISO	ASA	d	t	a	b	R																				
SCGN 0904 ZM	SCGN 33 ZM	9.52	4.76	1.23	5°	0.8															●					

SPECIAL INSERT

SVW

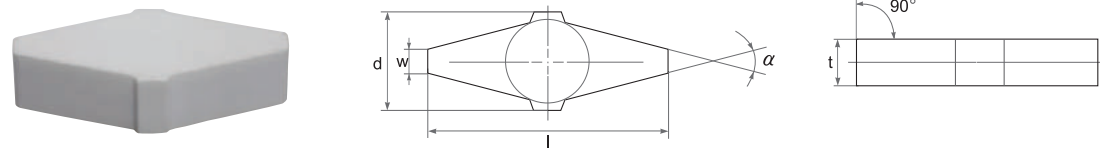

Type	Dimensions (mm)					ST100	ST300	ST500	ST900	SD200	SZ200	SZ300	SN26	SN300	SN400	SN500	SN600	SN800	SN950	SNT1000	SW400	SW800	Coated ST	Coated SN	Coated SW
	ISO	l	α	d	t																				
SVW 38260	26.00	38°	11.5	7.94	2.23						●														
SVW 38320	32.00	38°	14.5	7.94	3.22						●														
SVW 34400	40.00	34°	18.5	7.94	5.07						●														

GVGN

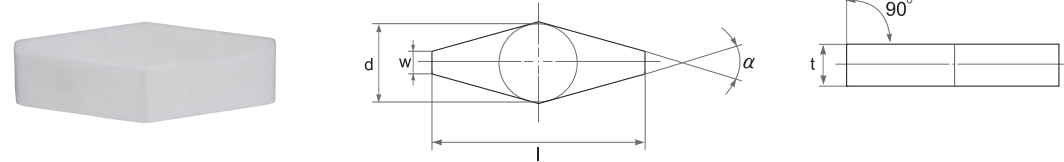

Type	Dimensions (mm)					ST100	ST300	ST500	ST900	SD200	SZ200	SZ300	SN26	SN300	SN400	SN500	SN600	SN800	SN950	SNT1000	SW400	SW800	Coated ST	Coated SN	Coated SW
	ISO	l	α	d	t																				
GVGN 38320	32.00	38°	13.46	7.94	3.22						●														
GVGN 38335	33.50	38°	13.28	8.00	3.06						●														
GVGN 36340	34.00	36°	13.59	7.94	3.25						●														
GVGN 38360	36.00	38°	17.38	7.94	5.98						●														
GVGN 34360	36.00	34°	17.42	7.94	7.22						●														

SPECIAL INSERT

SZT 5810

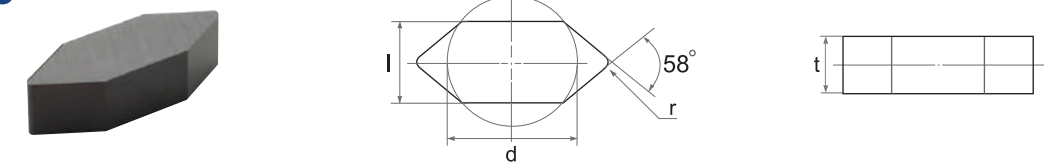

Type	Dimensions (mm)				ST100	ST300	ST500	ST900	SD200	SZ200	SZ300	SN26	SN300	SN400	SN500	SN600	SN800	SN950	SNT1000	SW400	SW800	Coated ST	Coated SN	Coated SW	
	ISO	d	l	t																					r
SZT 581004	14.70	10.00	7.94	0.4	●	●																			
SZT 581008	14.70	10.00	7.94	0.8	●	●																			
SZT 581012	14.70	10.00	7.94	1.2	●	●																			

SNMX

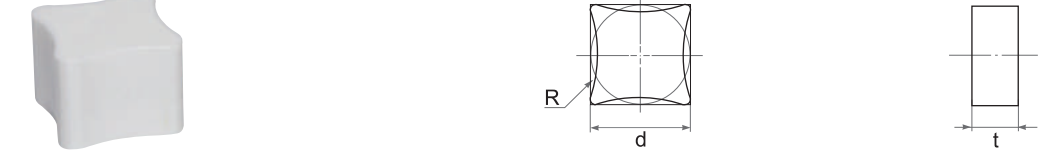

Type	Dimensions (mm)			ST100	ST300	ST500	ST900	SD200	SZ200	SZ300	SN26	SN300	SN400	SN500	SN600	SN800	SN950	SNT1000	SW400	SW800	Coated ST	Coated SN	Coated SW	
	ISO	d	t																					R
SNMX 121007	12.70	10.00	7.0						●															
SNMX 121009	12.70	10.00	9.0						●															
SNMX 121012	12.70	10.00	12.0						●															
SNMX 121015	12.70	10.00	15.0						●															
SNMX 121020	12.70	10.00	20.0						●															
SNMX 121025	12.70	10.00	25.0						●															
SNMX 121030	12.70	10.00	30.0						●															
SNMX 121040	12.70	10.00	40.0						●															
SNMX 121050	12.70	10.00	50.0						●															

SPECIAL INSERT

SPECIAL INSERT

SNGF

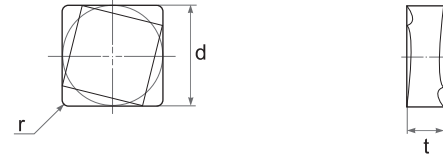

Type		Dimensions (mm)			ST100	ST300	ST500	ST900	SD200	SZ200	SZ300	SN26	SN300	SN400	SN500	SN600	SN800	SN950	SN1000	SW400	SW800	Coated ST	Coated SN	Coated SW	
ISO	ASA	d	t	r																					
SNGF 120412	SNGF 433	12.70	4.76	1.2										●											

INGN

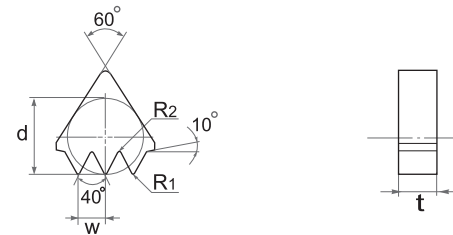

Type		Dimensions (mm)					ST100	ST300	ST500	ST900	SD200	SZ200	SZ300	SN26	SN300	SN400	SN500	SN600	SN800	SN950	SN1000	SW400	SW800	Coated ST	Coated SN	Coated SW
ISO		d	t	w	R ₁	R ₂																				
INGN 160435 F303		9.52	4.76	3.56	0.5	0.3					●															
INGN 160435 F304		9.52	4.76	3.56	0.5	0.4					●															
INGN 220435 F403		12.70	4.76	3.56	0.5	0.3					●															
INGN 220435 F404		12.70	4.76	3.56	0.5	0.4					●															

SPECIAL INSERT

ENDMILL (FINISHED)

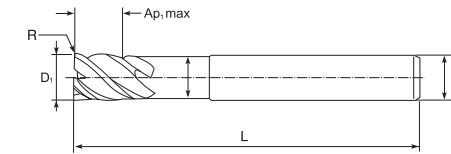

Type	Flute	Mill Diameter x Corner R	Length of Cut	Effective Length	Neck Diameter	Overall Length	Shank Diameter	SN1000	SW800
	F	∅ D ₁ xR	L ₁	L ₂	∅ d ₂	L	∅D		
SYC 6040 R0.5	4	∅6 X R 0.5	4.5	12	5.8	60	∅6		●
SYC 8040 R1.0	4	∅8 X R 1.0	6	16	7.7	60	∅8		●
SYC 10040 R1.25	4	∅10 X R 1.25	7.5	20	9.7	65	∅10	●	●
SYC 12040 R1.5	4	∅12 X R 1.5	9	24	11.7	70	∅12		●
SYC 6060 R0.5	6	∅6 X R 0.5	4.5	12	5.8	60	∅6		●
SYC 8060 R1.0	6	∅8 X R 1.0	6	16	7.7	60	∅8		●
SYC 10060 R1.25	6	∅10 X R 1.25	7.5	20	9.7	65	∅10	●	●
SYC 12060 R1.5	6	∅12 X R 1.5	9	24	11.7	70	∅12		●

SPECIAL INSERT

ENDMILL (FINISHED)

SPECIAL INSERT

ENDMILL (BLANK)

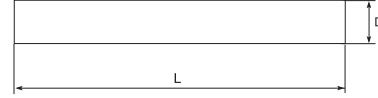

Type	Dimensions (mm)		ST100	ST300	ST500	ST900	SD200	SZ200	SZ300	SN26	SN300	SN400	SN500	SN600	SN800	SN950	SN1000	SW400	SW800	Coated ST	Coated SN	Coated SW	
	ISO	D																					L
ROD 060-600S	6	60																					
ROD 080-600S	8	60																					
ROD 100-650S	10	65																					
ROD 100-720S	10	72																					
ROD 120-700S	12	70																					
ROD 140-850S	14	85																					
ROD 160-900S	16	90																					
ROD 180-1000S	18	100																					
ROD 200-1050S	20	105																					

* Remarks : Available upon customer request

MEMO

CERMET

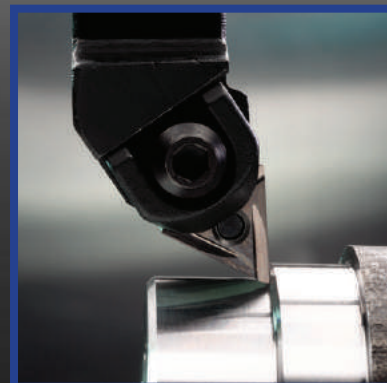
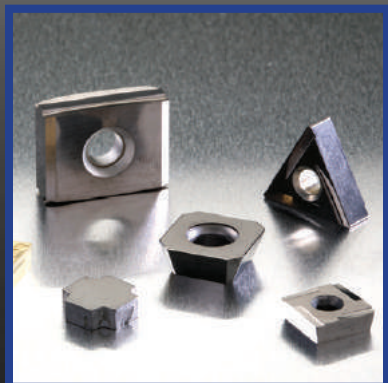

Turning A 86

Milling A 97

Special A 102

TURNING INSERT

CNMG

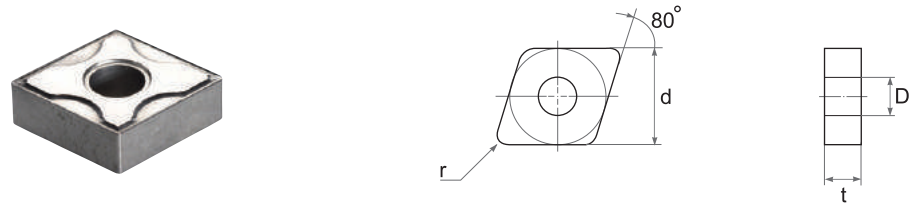

Type		Dimensions (mm)				Cermet (TiCN)			Cermet (PVD)		
ISO	ASA	d	t	r	D	TX515	TX520	TX530	TX915	TX920	TX930
CNMG 120404SF	CNMG 431SF	12.70	4.76	0.4	5.16	●	●				
CNMG 120408SF	CNMG 432SF	12.70	4.76	0.8	5.16	●	●			●	
CNMG 120412SF	CNMG 433SF	12.70	4.76	1.2	5.16						

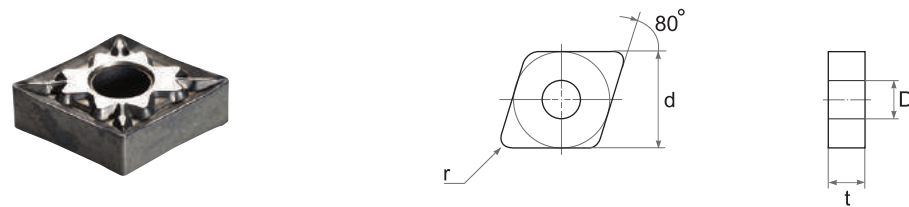

Type		Dimensions (mm)				Cermet (TiCN)			Cermet (PVD)		
ISO	ASA	d	t	r	D	TX515	TX520	TX530	TX915	TX920	TX930
CNMG 120404SY	CNMG 431SY	12.70	4.76	0.4	5.16	●	●	●		●	
CNMG 120408SY	CNMG 432SY	12.70	4.76	0.8	5.16	●	●	●		●	
CNMG 120412SY	CNMG 433SY	12.70	4.76	1.2	5.16	●	●			●	

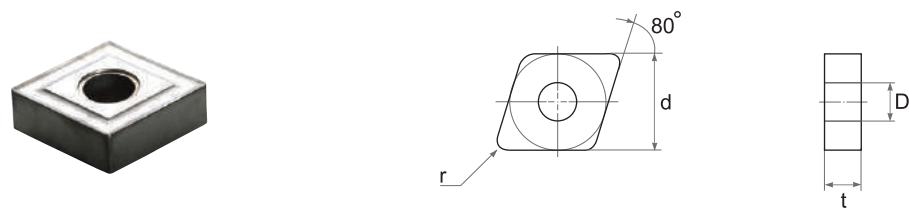

Type		Dimensions (mm)				Cermet (TiCN)			Cermet (PVD)		
ISO	ASA	d	t	r	D	TX515	TX520	TX530	TX915	TX920	TX930
CNMG 120404SG	CNMG 431SG	12.70	4.76	0.4	5.16	●	●	●			
CNMG 120408SG	CNMG 432SG	12.70	4.76	0.8	5.16	●	●	●			
CNMG 120412SG	CNMG 433SG	12.70	4.76	1.2	5.16			●	●		

TURNING INSERT

DNMG

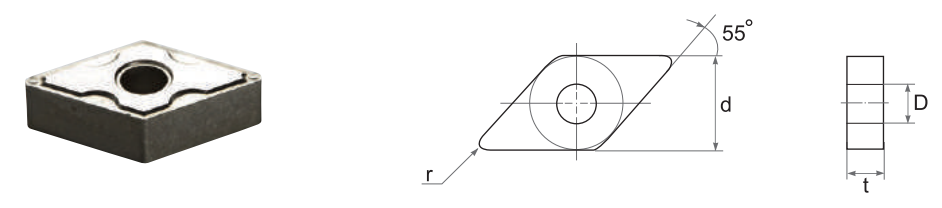

Type		Dimensions (mm)				Cermet (TiCN)			Cermet (PVD)		
ISO	ASA	d	t	r	D	TX515	TX520	TX530	TX915	TX920	TX930
DNMG 150404SF	DNMG 431SF	12.70	4.76	0.4	5.16	●	●			●	
DNMG 150408SF	DNMG 432SF	12.70	4.76	0.8	5.16	●	●			●	
DNMG 150412SF	DNMG 433SF	12.70	4.76	1.2	5.16	●	●				●
DNMG 150604SF	DNMG 441SF	12.70	6.35	0.4	5.16	●	●				
DNMG 150608SF	DNMG 442SF	12.70	6.35	0.8	5.16	●	●				
DNMG 150612SF	DNMG 443SF	12.70	6.35	1.2	5.16	●					

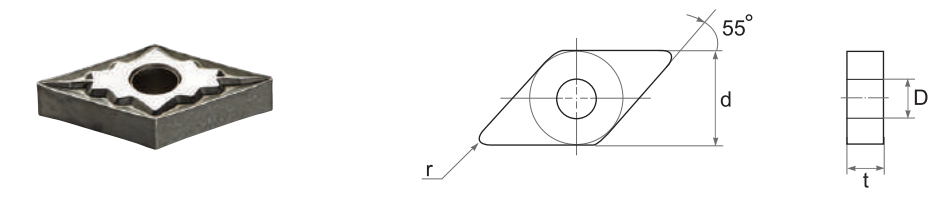

Type		Dimensions (mm)				Cermet (TiCN)			Cermet (PVD)		
ISO	ASA	d	t	r	D	TX515	TX520	TX530	TX915	TX920	TX930
DNMG 150404SY	DNMG 431SY	12.70	4.76	0.4	5.16	●	●			●	
DNMG 150408SY	DNMG 432SY	12.70	4.76	0.8	5.16	●	●			●	
DNMG 150412SY	DNMG 433SY	12.70	4.76	1.2	5.16	●	●				●
DNMG 150604SY	DNMG 441SY	12.70	6.35	0.4	5.16	●	●				
DNMG 150608SY	DNMG 442SY	12.70	6.35	0.8	5.16	●	●				
DNMG 150612SY	DNMG 443SY	12.70	6.35	1.2	5.16	●	●				

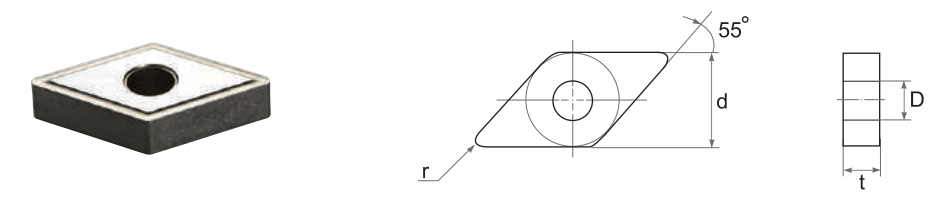

Type		Dimensions (mm)				Cermet (TiCN)			Cermet (PVD)		
ISO	ASA	d	t	r	D	TX515	TX520	TX530	TX915	TX920	TX930
DNMG 150404SG	DNMG 431SG	12.70	4.76	0.4	5.16	●	●				
DNMG 150408SG	DNMG 432SG	12.70	4.76	0.8	5.16	●	●				
DNMG 150412SG	DNMG 433SG	12.70	4.76	1.2	5.16	●	●				●
DNMG 150604SG	DNMG 441SG	12.70	6.35	0.4	5.16	●	●				
DNMG 150608SG	DNMG 442SG	12.70	6.35	0.8	5.16	●	●				
DNMG 150612SG	DNMG 443SG	12.70	6.35	1.2	5.16	●					

TURNING INSERT

SNMG

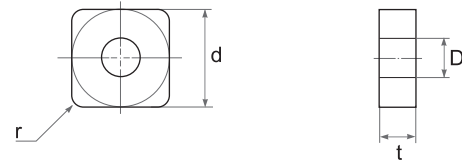

Type		Dimensions (mm)				Cermet (TiCN)			Cermet (PVD)		
ISO	ASA	d	t	r	D	TX515	TX520	TX530	TX915	TX920	TX930
SNMG 120404SF	SNMG 431SF	12.70	4.76	0.4	5.16	●	●		●		
SNMG 120408SF	SNMG 432SF	12.70	4.76	0.8	5.16	●	●		●		
SNMG 120412SF	SNMG 433SF	12.70	4.76	1.2	5.16	●	●				

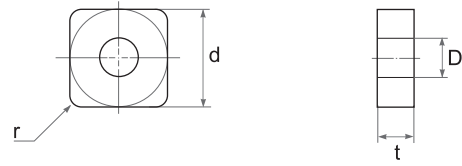

Type		Dimensions (mm)				Cermet (TiCN)			Cermet (PVD)		
ISO	ASA	d	t	r	D	TX515	TX520	TX530	TX915	TX920	TX930
SNMG 120404SY	SNMG 431SY	12.70	4.76	0.4	5.16	●	●	●		●	
SNMG 120408SY	SNMG 432SY	12.70	4.76	0.8	5.16	●	●			●	
SNMG 120412SY	SNMG 433SY	12.70	4.76	1.2	5.16	●	●				

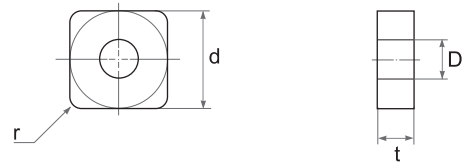
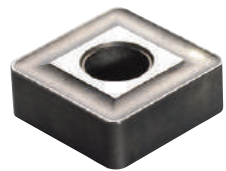

Type		Dimensions (mm)				Cermet (TiCN)			Cermet (PVD)		
ISO	ASA	d	t	r	D	TX515	TX520	TX530	TX915	TX920	TX930
SNMG 120404SG	SNMG 431SG	12.70	4.76	0.4	5.16	●	●				
SNMG 120408SG	SNMG 432SG	12.70	4.76	0.8	5.16	●	●				
SNMG 120412SG	SNMG 433SG	12.70	4.76	1.2	5.16	●	●				

TURNING INSERT

TNMG

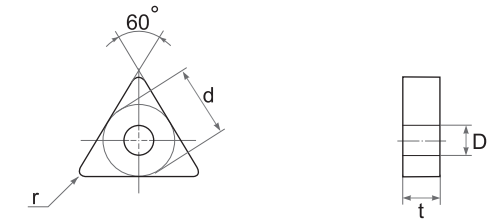

Type		Dimensions (mm)				Cermet (TiCN)			Cermet (PVD)		
ISO	ASA	d	t	r	D	TX515	TX520	TX530	TX915	TX920	TX930
TNMG 160404SY	TNMG 331SY	9.52	4.76	0.4	3.81	●	●				
TNMG 160408SY	TNMG 332SY	9.52	4.76	0.8	3.81						
TNMG 160412SY	TNMG 333SY	9.52	4.76	1.2	3.81	●	●				

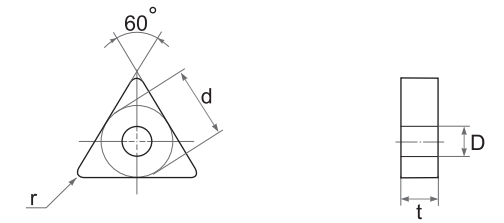

Type		Dimensions (mm)				Cermet (TiCN)			Cermet (PVD)		
ISO	ASA	d	t	r	D	TX515	TX520	TX530	TX915	TX920	TX930
TNMG 160404SG	TNMG 331SG	9.52	4.76	0.4	3.81	●	●				
TNMG 160408SG	TNMG 332SG	9.52	4.76	0.8	3.81	●	●				
TNMG 160412SG	TNMG 333SG	9.52	4.76	1.2	3.81	●	●				

VNMG

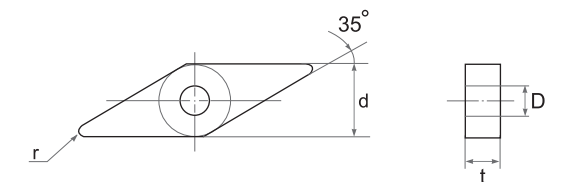

Type		Dimensions (mm)				Cermet (TiCN)			Cermet (PVD)		
ISO	ASA	d	t	r	D	TX515	TX520	TX530	TX915	TX920	TX930
VNMG 160404SG	VNMG 331SG	9.52	4.76	0.4	3.81	●	●				
VNMG 160408SG	VNMG 332SG	9.52	4.76	0.8	3.81	●	●				

TURNING INSERT

WNMG

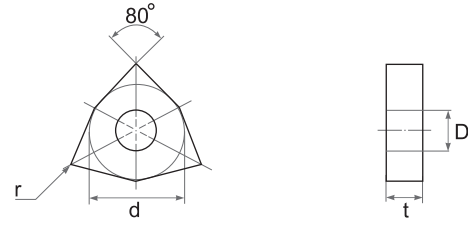

Type		Dimensions (mm)				Cermet (TiCN)			Cermet (PVD)		
ISO	ASA	d	t	r	D	TX515	TX520	TX530	TX915	TX920	TX930
WNMG 080404SY	WNMG 431SY	12.70	4.76	0.4	5.16	●	●		●	●	
WNMG 080408SY	WNMG 432SY	12.70	4.76	0.8	5.16	●	●		●	●	

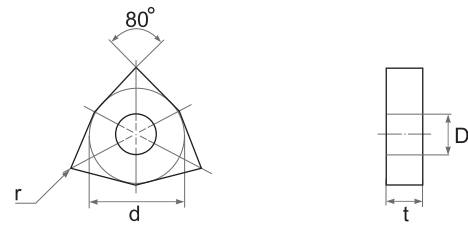

Type		Dimensions (mm)				Cermet (TiCN)			Cermet (PVD)		
ISO	ASA	d	t	r	D	TX515	TX520	TX530	TX915	TX920	TX930
WNMG 080404SG	WNMG 431SG	12.70	4.76	0.4	5.16	●	●		●		
WNMG 080408SG	WNMG 432SG	12.70	4.76	0.8	5.16	●	●				
WNMG 080412SG	WNMG 433SG	12.70	4.76	1.2	5.16	●	●				

TURNING INSERT

CCMT

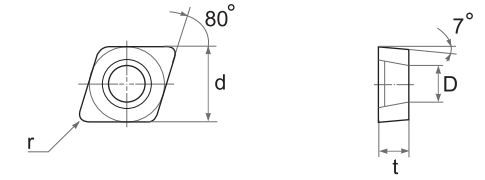

Type		Dimensions (mm)				Cermet (TiCN)			Cermet (PVD)		
ISO	ASA	d	t	r	D	TX515	TX520	TX530	TX915	TX920	TX930
CCMT 09T304		9.52	3.97	0.4	4.40	●	●		●		
CCMT 09T308		9.52	3.97	0.8	4.40	●	●				

DCGW

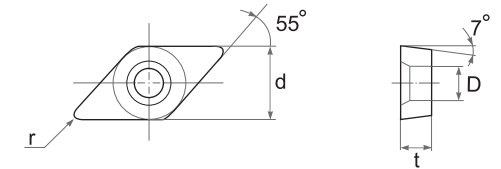
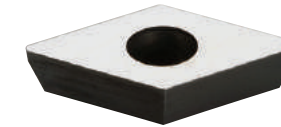

Type		Dimensions (mm)				Cermet (TiCN)			Cermet (PVD)		
ISO	ASA	d	t	r	D	TX515	TX520	TX530	TX915	TX920	TX930
DCGW 090304		8.50	3.18	0.4	3.60		●				
DCGW 11T304		9.52	3.97	0.4	4.40		●				

CPGT

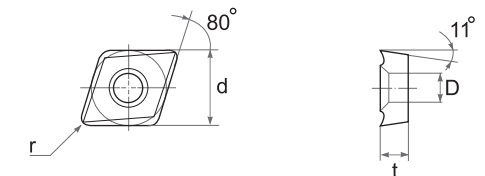
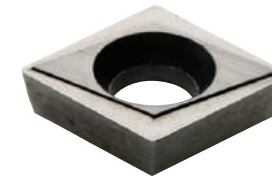

Type		Dimensions (mm)				Cermet (TiCN)			Cermet (PVD)		
ISO	ASA	d	t	r	D	TX515	TX520	TX530	TX915	TX920	TX930
CPGT 090304	CPGT 321	9.52	3.18	0.4	4.50	●	●	●			
CPGT 090308	CPGT 322	9.52	3.18	0.8	4.50	●	●	●			

TURNING INSERT

SPGT

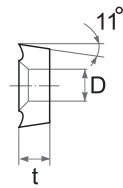
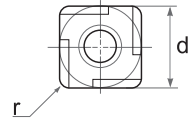

Type		Dimensions (mm)				Cermet (TiCN)			Cermet (PVD)		
ISO	ASA	d	t	r	D	TX515	TX520	TX530	TX915	TX920	TX930
SPGT 090304R/L	SPGT 321R/L	9.52	3.18	0.4	3.40	●					
SPGT 090308R/L	SPGT 322R/L	9.52	3.18	0.8	3.40	●					

TPGT

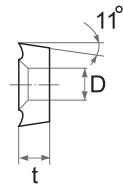
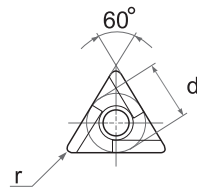

Type		Dimensions (mm)				Cermet (TiCN)			Cermet (PVD)		
ISO	ASA	d	t	r	D	TX515	TX520	TX530	TX915	TX920	TX930
TPGT 110302R/L	TPGT 2205R/L	6.35	3.18	0.2	3.56	●	●				
TPGT 110304R/L	TPGT 221R/L	6.35	3.18	0.4	3.56	●	●				
TPGT 110308R/L	TPGT 222R/L	6.35	3.18	0.8	3.56	●					
TPGT 160304R/L	TPGT 321R/L	9.52	3.18	0.4	4.46	●	●				
TPGT 160308R/L	TPGT 322R/L	9.52	3.18	0.8	4.46	●	●				
TPGT 160404R/L	TPGT 331R/L	9.52	4.76	0.4	4.40	●	●				
TPGT 160408R/L	TPGT 332R/L	9.52	4.76	0.8	4.40	●	●				

TPGT .. KC

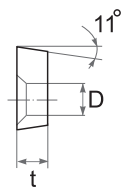
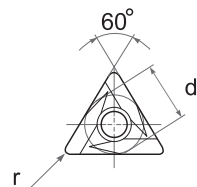

Type		Dimensions (mm)				Cermet (TiCN)			Cermet (PVD)		
ISO		d	t	r	D	TX515	TX520	TX530	TX915	TX920	TX930
TPGT 110304KC		6.35	3.18	0.4	3.56		●				

TURNING INSERT

TPGR

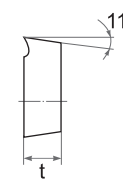
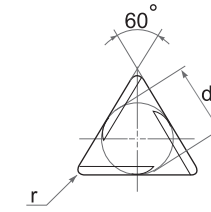

Type		Dimensions (mm)			Cermet (TiCN)			Cermet (PVD)		
ISO		d	t	r	TX515	TX520	TX530	TX915	TX920	TX930
TPGR 110302R/L		6.35	3.18	0.2	●					
TPGR 110304R/L		6.35	3.18	0.4	●					
TPGR 110308R/L		6.35	3.18	0.8						
TPGR 160302R/L		9.52	3.18	0.2	●					
TPGR 160304R/L		9.52	3.18	0.4	●		●			
TPGR 160308R/L		9.52	3.18	0.8	●					
TPGR 220404K-R/L		12.70	4.76	0.4	●		●			
TPGR 220408K-R/L		12.70	4.76	0.8	●					
TPGR 220412K-R/L		12.70	4.76	1.2	●					

SPMW

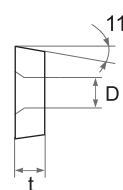
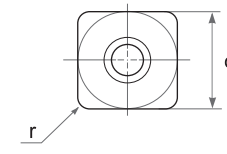
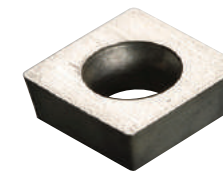

Type		Dimensions (mm)				Cermet (TiCN)			Cermet (PVD)		
ISO		d	t	r	D	TX515	TX520	TX530	TX915	TX920	TX930
SPMW 090304HS		9.52	3.18	0.4	3.4	●	●				
SPMW 090308HS		9.52	3.18	0.8	3.4	●	●				
SPMW 090304HL		9.52	3.18	0.4	4.6	●	●				
SPMW 090308HL		9.52	3.18	0.8	4.6	●	●				

TURNING INSERT

DNGG

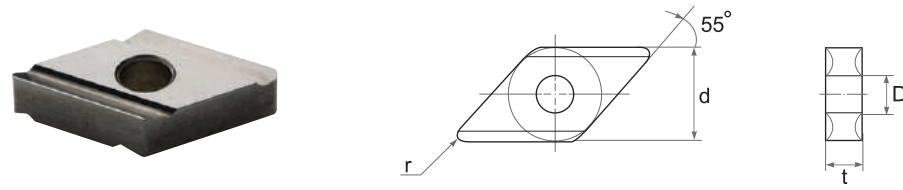

Type		Dimensions (mm)				Cermet (TiCN)			Cermet (PVD)		
ISO	ASA	d	t	r	D	TX515	TX520	TX530	TX915	TX920	TX930
DNGG 150404R/L	DNGG 431R/L	12.70	4.76	0.4	5.16	●	●			●	
DNGG 150408R/L	DNGG 432R/L	12.70	4.76	0.8	5.16	●	●				
DNGG 150604R/L	DNGG 441R/L	12.70	6.35	0.4	5.16	●	●				
DNGG 150608R/L	DNGG 442R/L	12.70	6.35	0.8	5.16	●	●				

SNGG

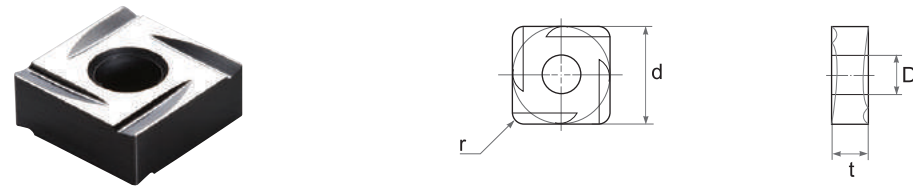

Type		Dimensions (mm)				Cermet (TiCN)			Cermet (PVD)		
ISO	ASA	d	t	r	D	TX515	TX520	TX530	TX915	TX920	TX930
SNGG 120404R/L	SNGG 431R/L	12.70	4.76	0.4	5.16	●	●				
SNGG 120408R/L	SNGG 432R/L	12.70	4.76	0.8	5.16	●	●				
SNGG 120412R/L	SNGG 433R/L	12.70	4.76	1.2	5.16						

SNGL

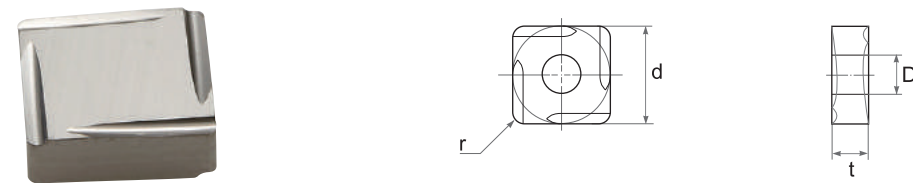

Type		Dimensions (mm)			Cermet (TiCN)			Cermet (PVD)		
ISO	d	t	r	TX515	TX520	TX530	TX915	TX920	TX930	
SNGL 070204R/L	7.14	2.38	0.4							

TURNING INSERT

TNGG

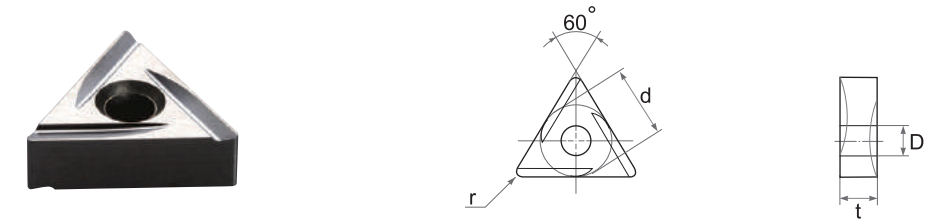

Type		Dimensions (mm)				Cermet (TiCN)			Cermet (PVD)		
ISO	ASA	d	t	r	D	TX515	TX520	TX530	TX915	TX920	TX930
TNGG 160402R/L	TNGG 3302R/L	9.52	4.76	0.2	3.81	●	●	●			
TNGG 160404R/L	TNGG 331R/L	9.52	4.76	0.4	3.81	●	●	●			
TNGG 160408R/L	TNGG 332R/L	9.52	4.76	0.8	3.81	●	●				
TNGG 220404R/L	TNGG 431R/L	12.70	4.76	0.4	5.16	●	●				
TNGG 220408R/L	TNGG 432R/L	12.70	4.76	0.8	5.16	●	●				

TNGG .. FS

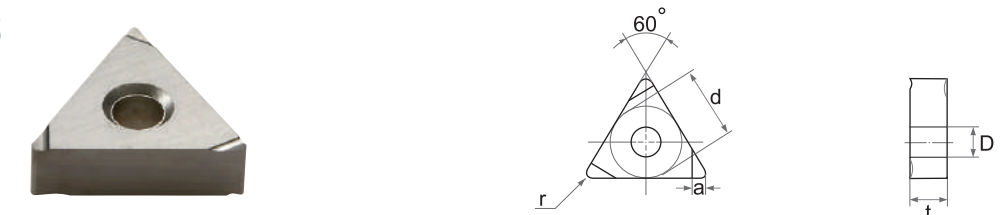

Type		Dimensions (mm)					Cermet (TiCN)			Cermet (PVD)		
ISO	d	t	r	D	a	TX515	TX520	TX530	TX915	TX920	TX930	
TNGG 160402R/L-FS	9.52	4.76	0.2	3.81	1.28	●	●			●		
TNGG 160404R/L-FS	9.52	4.76	0.4	3.81	1.28	●	●					
TNGG 160408R/L-FS	9.52	4.76	0.8	3.81	1.28	●	●					

TNGG .. F

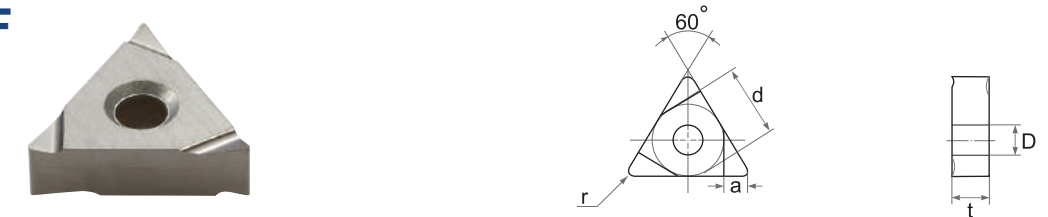

Type		Dimensions (mm)				Cermet (TiCN)			Cermet (PVD)		
ISO	d	t	r	D	a	TX515	TX520	TX530	TX915	TX920	TX930
TNGG 160402R/L-F	9.52	4.76	0.2	3.81	2.50	●	●				
TNGG 160404R/L-F	9.52	4.76	0.4	3.81	2.50	●	●			●	
TNGG 160408R/L-F	9.52	4.76	0.8	3.81	2.50	●	●				

TURNING INSERT

TNMG .. 2G

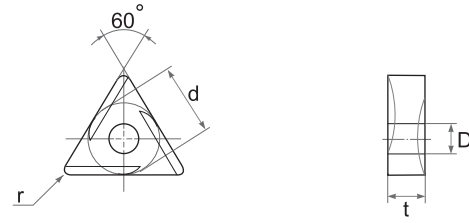

Type		Dimensions (mm)				Cermet (TiCN)			Cermet (PVD)		
ISO	ASA	d	t	r	D	TX515	TX520	TX530	TX915	TX920	TX930
TNMG 160404R/L 2G	TNMG 331R/L 2G	9.52	4.76	0.4	3.81	●	●	●		●	
TNMG 160408R/L 2G	TNMG 332R/L 2G	9.52	4.76	0.8	3.81	●	●			●	

MILLING INSERT

SDCN

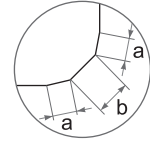
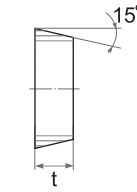
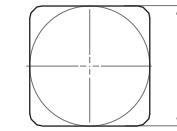

Type		Dimensions (mm)				Cermet (TiCN)			Cermet (PVD)		
ISO	ASA	d	t	a	b	TX515	TX520	TX530	TX915	TX920	TX930
SDCN 1203MT	SDCN 42MT	12.70	3.18	0.50	1.40		●	●			
SDCN 1504MT	SDCN 53MT	15.87	4.76	0.50	1.40			●			

SDKN

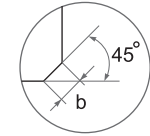
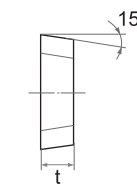
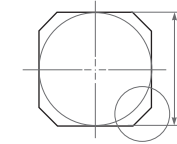

Type		Dimensions (mm)			Cermet (TiCN)			Cermet (PVD)		
ISO	ASA	d	t	r	TX515	TX520	TX530	TX915	TX920	TX930
SDKN 1203AETN	SDKN 42AETN	12.70	3.18	2.00		●	●			
SDKN 1504AETN	SDKN 53AETN	15.87	4.76	2.00		●	●			

SDEN

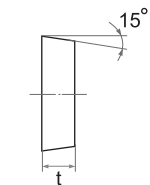
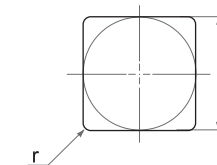

Type		Dimensions (mm)			Cermet (TiCN)			Cermet (PVD)		
ISO		d	t	r	TX515	TX520	TX530	TX915	TX920	TX930
SDEN 150404FN		15.87	4.76	0.4		●	●			

MILLING INSERT

SDEW

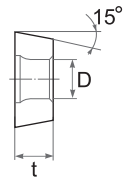
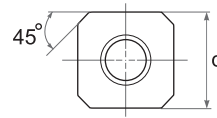

Type		Dimensions (mm)			Cermet (TiCN)			Cermet (PVD)		
ISO	ASA	d	t	D	TX515	TX520	TX530	TX915	TX920	TX930
SDEW 1204AZT	SDEW 43AZT	12.70	4.76	5.20		●	●			

SNK

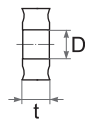
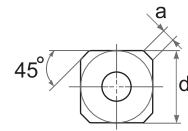
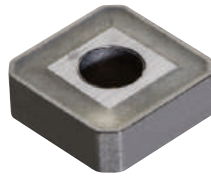

Type		Dimensions (mm)				Cermet (TiCN)			Cermet (PVD)		
ISO	ASA	d	t	D	a	TX515	TX520	TX530	TX915	TX920	TX930
SNK 0903AEN	SNK 32AEN	9.52	3.18	3.81	1.40	●					

SEHW

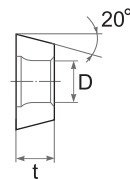
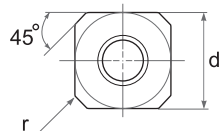

Type		Dimensions (mm)				Cermet (TiCN)			Cermet (PVD)		
ISO	ASA	d	t	D	r	TX515	TX520	TX530	TX915	TX920	TX930
SEHW 120408AE	SEHW 432AE	12.70	4.76	5.50	0.8			●			●

MILLING INSERT

SEKN

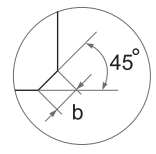
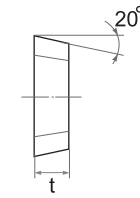
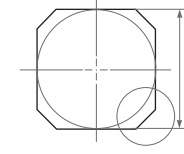

Type		Dimensions (mm)			Cermet (TiCN)			Cermet (PVD)		
ISO	ASA	d	t	b	TX515	TX520	TX530	TX915	TX920	TX930
SEKN 1203 AFTN	SEKN 42 AFTN	12.70	3.18	2.00	●	●	●			●
SEKN 1504 AFTN	SEKN 53 AFTN	15.87	4.76	2.00		●	●			●

SEKN .. R

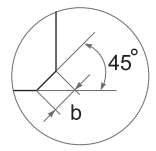
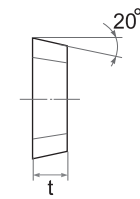
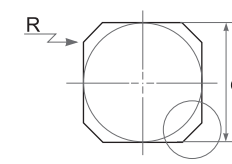
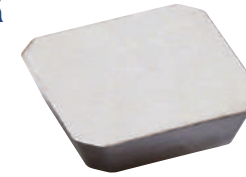

Type		Dimensions (mm)				Cermet (TiCN)			Cermet (PVD)		
ISO	ASA	d	t	b	R	TX515	TX520	TX530	TX915	TX920	TX930
SEKN 120308 AFTN	SEKN 432 AFTN	12.70	3.18	2.00	0.8		●	●			
SEKN 150408 AFTN	SEKN 532 AFTN	15.87	4.76	2.00	0.8						

SPKN

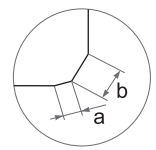
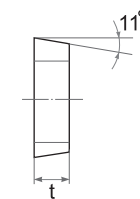
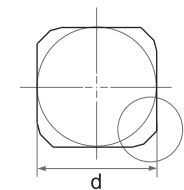

Type		Dimensions (mm)				Cermet (TiCN)			Cermet (PVD)		
ISO	ASA	d	t	a	b	TX515	TX520	TX530	TX915	TX920	TX930
SPKN 1203EDTR/L	SPKN 42EDTR/L	12.70	3.18	1.00	1.40		●	●			
SPKN 1504EDTR/L	SPKN 53EDTR/L	15.87	4.76	1.00	1.40		●	●			

MILLING INSERT

TEKN

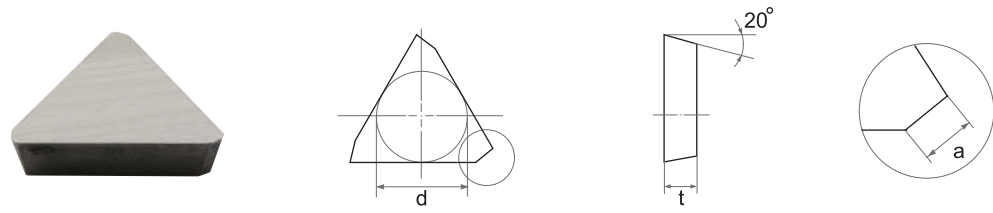

Type		Dimensions (mm)			Cermet (TiCN)			Cermet (PVD)		
ISO	ASA	d	t	a	TX515	TX520	TX530	TX915	TX920	TX930
TEKN 1603PETR/L	TEKN 32PETR/L	9.52	3.18	1.40		●	●			
TEKN 2204PETR/L	TEKN 43PETR/L	12.70	4.76	2.00		●	●			
TEKN 1603PEER/L	TEKN 32PEER/L	9.52	3.18	1.40		●	●			
TEKN 2204PEER/L	TEKN 43PEER/L	12.70	4.76	2.00		●	●			

TPKN

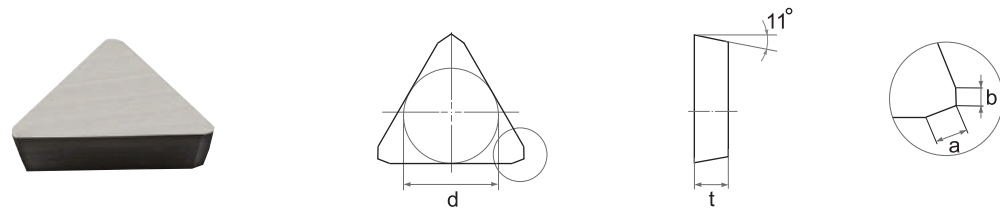

Type		Dimensions (mm)				Cermet (TiCN)			Cermet (PVD)		
ISO	ASA	d	t	a	b	TX515	TX520	TX530	TX915	TX920	TX930
TPKN 1603PDTR/L	TPKN 32PDTR/L	9.52	3.18	1.20	1.00		●	●			
TPKN 2204PDTR/L	TPKN 43PDTR/L	12.70	4.76	1.40	0.70		●	●			

MILLING INSERT

YCE

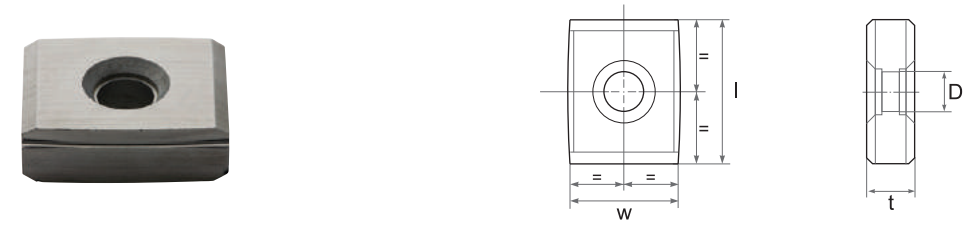

Type	Dimensions (mm)				Cermet (TiCN)			Cermet (PVD)		
ISO	l	w	t	D	TX515	TX520	TX530	TX915	TX920	TX930
YCE 434-01	19.05	14.29	6.35	5.25	●	●				

XCET

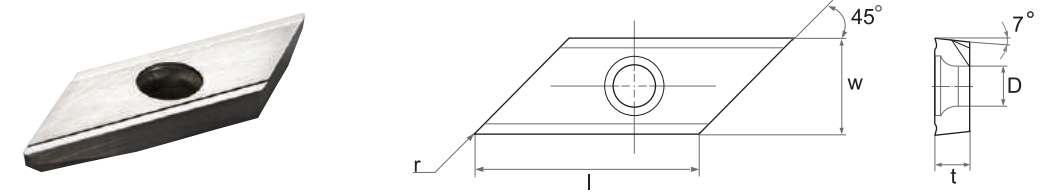

Type	Dimensions (mm)					Cermet (TiCN)			Cermet (PVD)		
ISO	l	w	t	D	r	TX515	TX520	TX530	TX915	TX920	TX930
XCET 310404 ER	22.00	12.70	4.50	5.60	0.4		●			●	
XCET 310408 ER	22.00	12.70	4.50	5.60	0.8		●				

SPECIAL INSERT

BSN

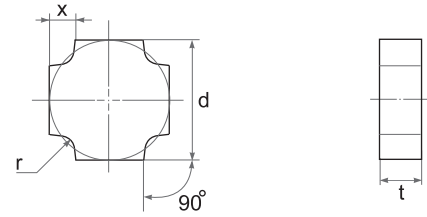
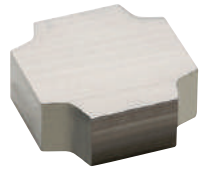

Type	Dimensions (mm)				Cermet (TiCN)			Cermet (PVD)			
	ISO	d	x	t	r	TX515	TX520	TX530	TX915	TX920	TX930
BSN 090306	9.52	2.00	3.18	0.6		●					
BSN 090310	9.52	2.57	3.18	1.0		●					
BSN 120406	12.70	2.14	4.76	0.6		●					
BSN 120410	12.70	2.40	4.76	1.0		●					
BSN 120415	12.70	3.00	4.76	1.5		●					
BSN 120420	12.70	3.45	4.76	2.0		●					
BSN 150525	15.87	4.00	5.56	2.5		●					
BSN 150530	15.87	4.70	5.56	3.0		●					

BTN

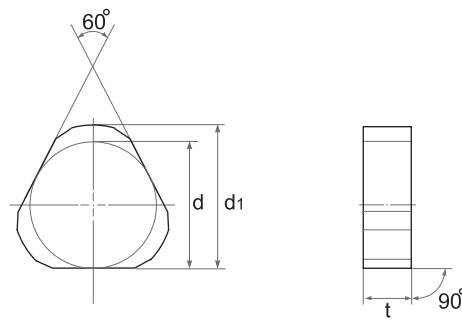
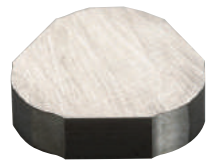

Type	Dimensions (mm)			Cermet (TiCN)			Cermet (PVD)			
	ISO	d	d ₁	t	TX515	TX520	TX530	TX915	TX920	TX930
BTN 1464	12.70	14.60	4.76		●					
BTN 1714	15.87	17.10	4.76	●	●					
BTN 2116	19.05	21.10	6.00		●					
BTN 2416	22.22	24.10	6.00		●					
BTN 2718	25.40	27.10	8.80		●					

SPECIAL INSERT

GBF

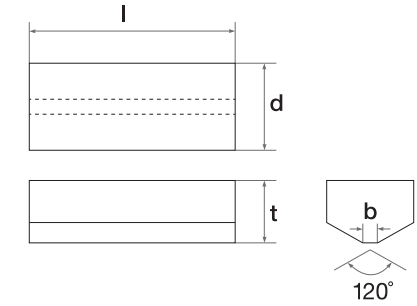
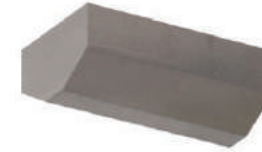

Type	Dimensions (mm)				Cermet (TiCN)			Cermet (PVD)			
	ISO	d	l	t	b	TX515	TX520	TX530	TX915	TX920	TX930
GBF 127250 B	12.70	25.00	8.00	2.3		●					
GBF 150250 B	15.00	25.00	9.50	2.3		●					
GBF 200300 B	20.00	30.00	9.50	2.5		●					

INGN

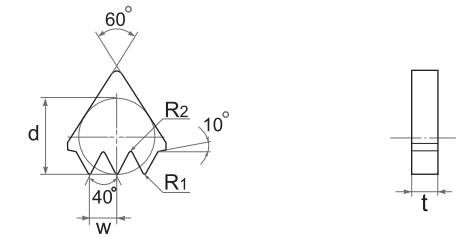

Type	Dimensions (mm)					Cermet (TiCN)			Cermet (PVD)			
	ISO	d	t	w	R ₁	R ₂	TX515	TX520	TX530	TX915	TX920	TX930
INGN 160435 F303	9.52	4.76	3.56	0.5	0.3		●					
INGN 160435 F304	9.52	4.76	3.56	0.5	0.4		●				●	
INGN 220435 F403	12.70	4.76	3.56	0.5	0.3							
INGN 220435 F404	12.70	4.76	3.56	0.5	0.4							

SPECIAL INSERT

GBF

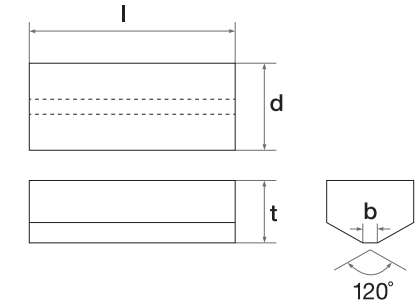

Type	Dimensions (mm)				Cermet (TiCN)			Cermet (PVD)			
	ISO	d	l	t	b	TX515	TX520	TX530	TX915	TX920	TX930
GBF 127250 B	12.70	25.00	8.00	2.3		●					
GBF 150250 B	15.00	25.00	9.50	2.3		●					
GBF 200300 B	20.00	30.00	9.50	2.5		●					

INGN

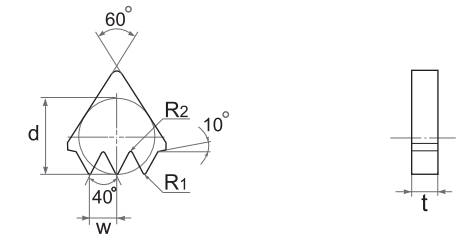

Type	Dimensions (mm)					Cermet (TiCN)			Cermet (PVD)			
	ISO	d	t	w	R ₁	R ₂	TX515	TX520	TX530	TX915	TX920	TX930
INGN 160435 F303	9.52	4.76	3.56	0.5	0.3		●					
INGN 160435 F304	9.52	4.76	3.56	0.5	0.4		●				●	
INGN 220435 F403	12.70	4.76	3.56	0.5	0.3							
INGN 220435 F404	12.70	4.76	3.56	0.5	0.4							

BLANK

RBAR

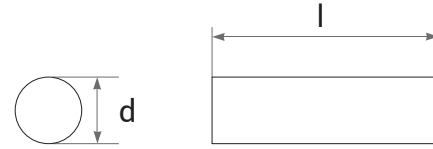

Type	Dimensions (mm)		Cermet (TiCN)			Cermet (PVD)		
	ISO	d	l	TX515	TX520	TX530	TX915	TX920
RBAR 2230 B	30.8	22.8			●			
RBAR 2507 B	7.8	25.8			●			
RBAR 2508 B	8.8	25.8			●			
RBAR 2509 B	9.8	25.8			●			
RBAR 2510 B	10.8	25.8			●			
RBAR 2511 B	11.8	25.8			●			
RBAR 2512 B	12.8	25.8			●			
RBAR 2513 B	13.8	25.8			●			
RBAR 2514 B	14.8	25.8			●			
RBAR 2515 B	15.8	25.8			●			
RBAR 2516 B	16.8	25.8			●			
RBAR 2517 B	17.8	25.8			●			
RBAR 2518 B	18.8	25.8			●			
RBAR 2519 B	19.8	25.8			●			
RBAR 2520 B	20.8	25.8			●			
RBAR 2521 B	21.8	25.8			●			
RBAR 2525 B	25.8	25.8			●			
RBAR 2530 B	30.8	25.8			●			
RBAR 2535 B	35.8	25.8			●			
RBAR 2640 B	40.8	26.8			●			
RBAR 2950 B	50.8	29.8			●			
RBAR 3007 B	7.8	30.8			●			
RBAR 3008 B	8.8	30.8			●			
RBAR 3009 B	9.8	30.8			●			
RBAR 3010 B	10.8	30.8			●			
RBAR 3011 B	11.8	30.8			●			
RBAR 3012 B	12.8	30.8			●			
RBAR 3013 B	13.8	30.8			●			
RBAR 3014 B	14.8	30.8			●			
RBAR 3016 B	16.8	30.8			●			
RBAR 3017 B	17.8	30.8			●			
RBAR 3018 B	18.8	30.8			●			
RBAR 3019 B	19.8	30.8			●			
RBAR 3025 B	25.8	30.8			●			
RBAR 3040 B	40.8	30.8			●			
RBAR 3045 B	45.8	30.8			●			
RBAR 3050 B	50.8	30.8			●			
RBAR 3507 B	7.8	35.8			●			

CERAMIC

CERMET

PCBN / PCD

TOOL HOLDER

MILLING CUTTER

BLANK

RBAR

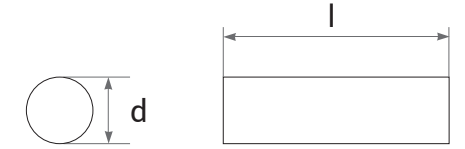

Type	Dimensions (mm)		Cermet (TiCN)			Cermet (PVD)		
	ISO	d	l	TX515	TX520	TX530	TX915	TX920
RBAR 3508 B	8.8	35.8			●			
RBAR 3509 B	9.8	35.8			●			
RBAR 3510 B	10.8	35.8			●			
RBAR 3511 B	11.8	35.8			●			
RBAR 3512 B	12.8	35.8			●			
RBAR 3513 B	13.8	35.8			●			
RBAR 3514 B	14.8	35.8			●			
RBAR 3515 B	15.8	35.8			●			
RBAR 3516 B	16.8	35.8			●			
RBAR 3517 B	17.8	35.8			●			
RBAR 3518 B	18.8	35.8			●			
RBAR 3519 B	19.8	35.8			●			
RBAR 3520 B	20.8	35.8			●			
RBAR 3521 B	21.8	35.8			●			
RBAR 3523 B	23.8	35.8			●			
RBAR 3525 B	25.8	35.8			●			
RBAR 3526 B	26.8	35.8			●			
RBAR 3530 B	30.8	35.8			●			
RBAR 3535 B	35.8	35.8			●			
RBAR 3540 B	40.8	35.8			●			
RBAR 3550 B	50.8	35.8			●			
RBAR 3555 B	55.8	35.8			●			
RBAR 3560 B	60.8	35.8			●			
RBAR 3565 B	65.8	35.8			●			
RBAR 3570 B	70.8	35.8			●			
RBAR 4030 B	30.8	40.8			●			
RBAR 4042 B	42.8	40.8			●			
RBAR 4045 B	45.8	40.8			●			
RBAR 4050 B	50.8	40.8			●			
RBAR 4060 B	60.8	40.8			●			
RBAR 4070 B	70.8	40.8			●			
RBAR 4080 B	80.8	40.8			●			
RBAR 4090 B	90.8	40.8			●			
RBAR 5055 B	55.8	50.8			●			
RBAR 5060 B	60.8	50.8			●			

CERAMIC

CERMET

PCBN / PCD

TOOL HOLDER

MILLING CUTTER

BLANK

SBAR

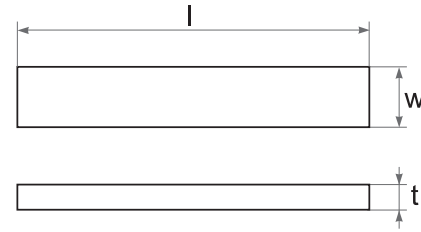

Type	Dimensions (mm)			Cermet (TiCN)			Cermet (PVD)			
	ISO	l	w	t	TX515	TX520	TX530	TX915	TX920	TX930
SBAR 040825	26.11	8.89	5.30		●					
SBAR 041608	16.67	4.75	8.10		●					
SBAR 050518	18.01	5.15	5.00		●					
SBAR 050620	22.35	4.95	6.30		●					
SBAR 056440	47.31	6.78	5.50		●					
SBAR 060331	34.75	5.94	6.35		●					
SBAR 121985	19.10	12.67	8.50		●					
SBAR 122025	25.50	1.40	2.20		●					
SBAR 122525	25.50	1.40	2.70		●					
SBAR 1295632	12.90	5.60	3.20		●					
SBAR 151985	19.10	15.30	8.50		●					
SBAR 163025	29.82	3.47	1.60		●					
SBAR 163315	15.62	3.41	1.60		●					
SBAR 163815	16.67	4.75	1.60		●					
SBAR 173815	15.06	3.69	1.70		●					
SBAR 203530	29.59	3.44	2.00		●					
SBAR 204035	34.53	3.94	2.00		●					
SBAR 704035	34.78	3.97	7.00		●					
SBAR 224816	16.67	4.72	2.20		●					
SBAR 255022	22.18	4.92	2.50		●					
SBAR 256035	34.49	5.89	2.50		●					
SBAR 306035	34.75	6.00	3.00		●					
SBAR 324850	3.60	5.10	50.00		●					
SBAR 326650	3.60	7.00	50.00		●					
SBAR 345022	22.35	4.95	3.40		●					
SBAR 327025	24.44	7.09	3.35		●					
SBAR 325075	71.94	14.39	3.20		●					
SBAR 327050	50.00	7.00	3.20		●					
SBAR 368950	50.40	8.92	3.60		●					
SBAR 328550	50.03	8.85	3.20		●					
SBAR 607050	50.40	8.92	6.50		●					
SBAR 638232	32.72	8.99	6.30		●					
SBAR 202525	25.40	2.70	2.20		●					
SBAR 224035	34.53	3.94	2.20		●					
SBAR 368232	32.72	8.99	3.60		●					

MEMO

PCBN / PCD

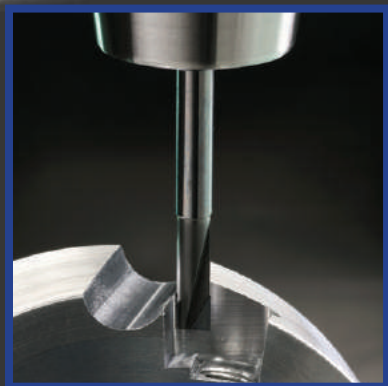

PCBN	A 110
- STANDARD	A 110
- Mini Tip	A 114
- Full Face	A 117
- Solid	A 118
PCD	A 120
- STANDARD	A 120
Special	A 126

PCBN

STANDARD

CNGA

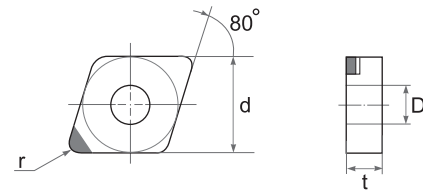

Type		Dimensions (mm)							
ISO	ASA	d	t	r	D	SBN 1000	SBN 2000	SBN 3000	SBN 4000
CNGA 120402 R1	CNGA 4302 R1	12.70	4.76	0.2	5.16				
CNGA 120404 R1	CNGA 431 R1	12.70	4.76	0.4	5.16	●	●		
CNGA 120408 R1	CNGA 432 R1	12.70	4.76	0.8	5.16	●	●	●	●
CNGA 120412 R1	CNGA 433 R1	12.70	4.76	1.2	5.16	●	●	●	●

CCGW

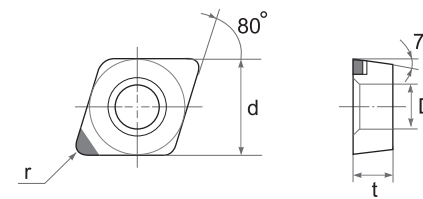

Type		Dimensions (mm)							
ISO		d	t	r	D	SBN 1000	SBN 2000	SBN 3000	SBN 4000
CCGW 060202 R1		6.35	2.38	0.2	2.80		●		
CCGW 060204 R1		6.35	2.38	0.4	2.80	●	●		
CCGW 060208 R1		6.35	2.38	0.8	2.80				
CCGW 09T304 R1		9.52	3.97	0.4	4.40	●	●	●	●
CCGW 09T308 R1		9.52	3.97	0.8	4.40	●	●	●	●

DNGA

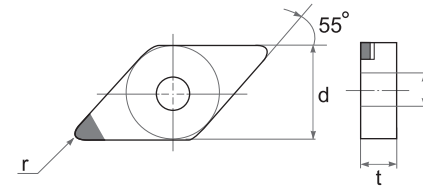

Type		Dimensions (mm)							
ISO	ASA	d	t	r	D	SBN 1000	SBN 2000	SBN 3000	SBN 4000
DNGA 150404 R1	DNGA 431 R1	12.70	4.76	0.4	5.16	●	●	●	
DNGA 150408 R1	DNGA 432 R1	12.70	4.76	0.8	5.16	●	●	●	●
DNGA 150412 R1	DNGA 433 R1	12.70	4.76	1.2	5.16	●	●	●	●
DNGA 150604 R1	DNGA 441 R1	12.70	6.35	0.4	5.16	●	●	●	
DNGA 150608 R1	DNGA 442 R1	12.70	6.35	0.8	5.16	●	●	●	●
DNGA 150612 R1	DNGA 443 R1	12.70	6.35	1.2	5.16	●	●	●	●

DNGA ... CB

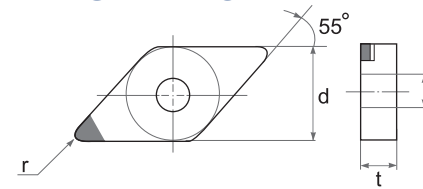

Type		Dimensions (mm)							
ISO	ASA	d	t	r	D	SBN 1000	SBN 2000	SBN 3000	SBN 4000
DNGA 150408 M2 CB	DNGA 432 M2 CB	12.70	4.76	0.8	5.16	●	●	●	●

DCGW

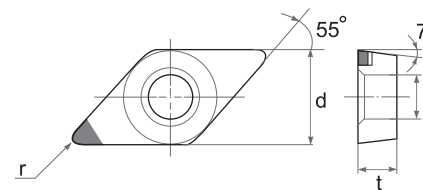

Type		Dimensions (mm)							
ISO		d	t	r	D	SBN 1000	SBN 2000	SBN 3000	SBN 4000
DCGW 070202 R1		6.35	2.38	0.2	2.80		●		
DCGW 070204 R1		6.35	2.38	0.4	2.80	●	●	●	
DCGW 070208 R1		6.35	2.38	0.8	2.80	●	●	●	●
DCGW 11T302 R1		9.52	3.97	0.2	4.40		●		
DCGW 11T304 R1		9.52	3.97	0.4	4.40	●	●	●	
DCGW 11T308 R1		9.52	3.97	0.8	4.40	●	●	●	●

PCBN

STANDARD

SNGA

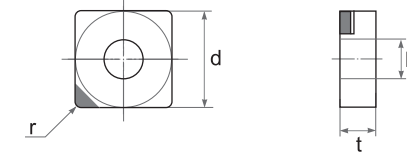

Type		Dimensions (mm)							
ISO	ASA	d	t	r	D	SBN 1000	SBN 2000	SBN 3000	SBN 4000
SNGA 090304 R1	SNGA 321 R1	9.52	3.18	0.4	3.81				
SNGA 120404 R1	SNGA 431 R1	12.70	4.76	0.4	5.16	●	●		
SNGA 120408 R1	SNGA 432 R1	12.70	4.76	0.8	5.16	●	●	●	●
SNGA 120412 R1	SNGA 433 R1	12.70	4.76	1.2	5.16	●	●	●	●

SNGN

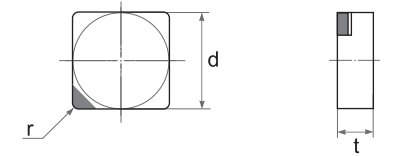

Type		Dimensions (mm)							
ISO	ASA	d	t	r	D	SBN 1000	SBN 2000	SBN 3000	SBN 4000
SNGN 090304 R1	SNGN 321 R1	9.52	3.18	0.4					
SNGN 090308 R1	SNGN 322 R1	9.52	3.18	0.8					
SNGN 090312 R1	SNGN 323 R1	9.52	3.18	1.2					
SNGN 120404 R1	SNGN 431 R1	12.70	4.76	0.4		●	●		
SNGN 120408 R1	SNGN 432 R1	12.70	4.76	0.8		●	●	●	●
SNGN 120412 R1	SNGN 433 R1	12.70	4.76	1.2		●	●	●	●

SCGW

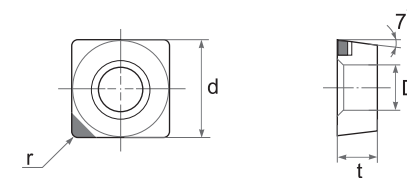

Type		Dimensions (mm)							
ISO		d	t	r	D	SBN 1000	SBN 2000	SBN 3000	SBN 4000
SCGW 09T304 R1		9.52	3.97	0.4	4.40	●	●		
SCGW 09T308 R1		9.52	3.97	0.8	4.40	●	●	●	●

TNGA

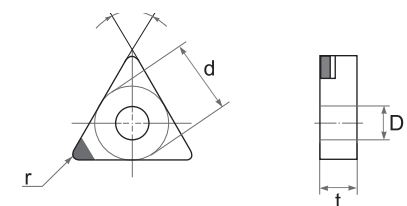

Type		Dimensions (mm)							
ISO	ASA	d	t	r	D	SBN 1000	SBN 2000	SBN 3000	SBN 4000
TNGA 160402 R1	TNGA 3302 R1	9.52	4.76	0.2	3.81	●	●		
TNGA 160404 R1	TNGA 331 R1	9.52	4.76	0.4	3.81	●	●		
TNGA 160408 R1	TNGA 332 R1	9.52	4.76	0.8	3.81	●	●	●	●
TNGA 160412 R1	TNGA 333 R1	9.52	4.76	1.2	3.81	●	●		

PCBN

STANDARD

TCGW

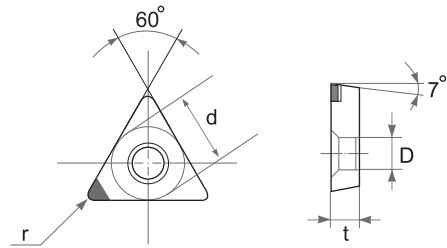

Type		Dimensions (mm)							
ISO		d	t	r	D	SBN 1000	SBN 2000	SBN 3000	SBN 4000
TCGW 090204 R1		5.56	2.38	0.4	2.50	●	●		
TCGW 090208 R1		5.56	2.38	0.8	2.50	●	●	●	●
TCGW 110202 R1		6.35	2.38	0.2	2.80		●		
TCGW 110204 R1		6.35	2.38	0.4	2.80	●	●		
TCGW 110208 R1		6.35	2.38	0.8	2.80	●	●	●	●
TCGW 16T304 R1		9.52	3.97	0.4	4.40	●	●		
TCGW 16T308 R1		9.52	3.97	0.8	4.40	●	●	●	●

TPGN

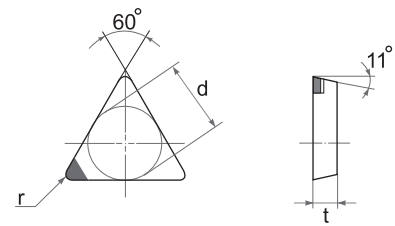

Type		Dimensions (mm)							
ISO	ASA	d	t	r	D	SBN 1000	SBN 2000	SBN 3000	SBN 4000
TPGN 110304 R1	TPGN 221 R1	6.35	3.18	0.4	2.80	●	●		
TPGN 110308 R1	TPGN 222 R1	6.35	3.18	0.8	2.80	●	●	●	●
TPGN 110312 R1	TPGN 223 R1	6.35	3.18	1.2	2.80				
TPGN 160304 R1	TPGN 321 R1	9.52	3.18	0.4	4.40	●	●		
TPGN 160308 R1	TPGN 322 R1	9.52	3.18	0.8	4.40	●	●	●	●
TPGN 160312 R1	TPGN 323 R1	9.52	3.18	1.2	4.40				

TPGB

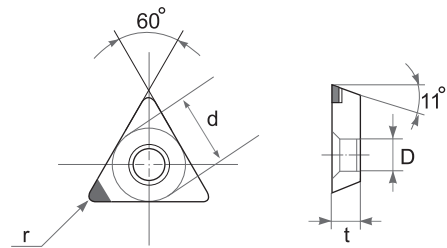

Type		Dimensions (mm)							
ISO	ASA	d	t	r	D	SBN 1000	SBN 2000	SBN 3000	SBN 4000
TPGB 080202 R1	TPGB 6302 R1	4.76	2.38	0.2	2.40				
TPGB 090204 R1	TPGB 731 R1	5.56	2.38	0.4	2.50	●	●		
TPGB 110302 R1	TPGB 2202 R1	6.35	3.18	0.2	3.30				
TPGB 110304 R1	TPGB 221 R1	6.35	3.18	0.4	3.30				
TPGB 110308 R1	TPGB 222 R1	6.35	3.18	0.8	3.30				

TPGW

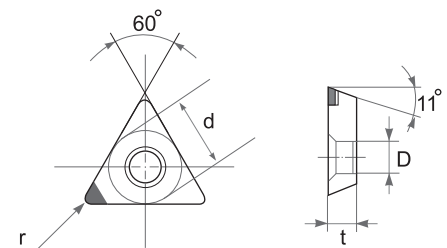

Type		Dimensions (mm)							
ISO	ASA	d	t	r	D	SBN 1000	SBN 2000	SBN 3000	SBN 4000
TPGW 160304 R1	TPGW 321 R1	9.52	3.18	0.4	4.40				
TPGW 160308 R1	TPGW 322 R1	9.52	3.18	0.8	4.40				

PCBN

STANDARD

VNGA

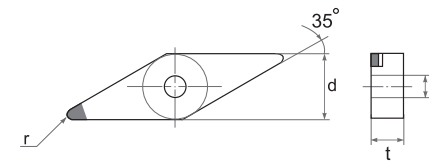

Type		Dimensions (mm)							
ISO	ASA	d	t	r	D	SBN 1000	SBN 2000	SBN 3000	SBN 4000
VNGA 160404 R1	VNGA 331 R1	9.52	4.76	0.4	3.18	●	●		
VNGA 160408 R1	VNGA 332 R1	9.52	4.76	0.8	3.18	●	●	●	●

VBGW

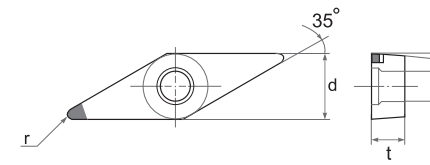

Type		Dimensions (mm)							
ISO	ASA	d	t	r	D	SBN 1000	SBN 2000	SBN 3000	SBN 4000
VBGW 110302 R1	VBGW 2202 R1	6.35	3.18	0.2	2.80				
VBGW 110304 R1	VBGW 221 R1	6.35	3.18	0.4	2.80				
VBGW 160404 R1	VBGW 331 R1	9.52	4.76	0.4	4.40	●	●		
VBGW 160408 R1	VBGW 332 R1	9.52	4.76	0.8	4.40	●	●	●	●

VCGW

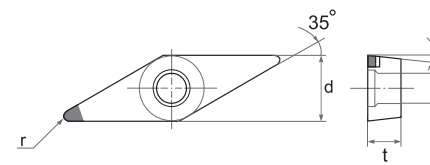

Type		Dimensions (mm)							
ISO	ASA	d	t	r	D	SBN 1000	SBN 2000	SBN 3000	SBN 4000
VCGW 110302 R1	VCGW 2202 R1	6.35	3.18	0.2	2.80				
VCGW 110304 R1	VCGW 221 R1	6.35	3.18	0.4	2.80				
VCGW 160404 R1	VCGW 331 R1	9.52	4.76	0.4	4.40	●	●		
VCGW 160408 R1	VCGW 332 R1	9.52	4.76	0.8	4.40	●	●	●	●

PCBN

MINI TIP

CNGA

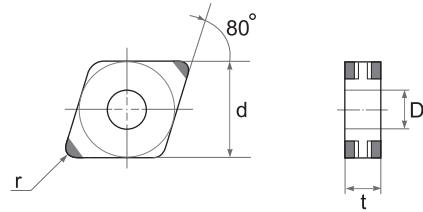

Type		Dimensions (mm)							
ISO	ASA	d	t	r	D	SBN 1000	SBN 2000	SBN 3000	SBN 4000
CNGA 120404 M1	CNGA 431 M1	12.70	4.76	0.4	5.16				
CNGA 120404 M2	CNGA 431 M2	12.70	4.76	0.4	5.16			●	●
CNGA 120404 M4	CNGA 431 M4	12.70	4.76	0.4	5.16				
CNGA 120408 M1	CNGA 432 M1	12.70	4.76	0.8	5.16				
CNGA 120408 M2	CNGA 432 M2	12.70	4.76	0.8	5.16			●	●
CNGA 120408 M4	CNGA 432 M4	12.70	4.76	0.8	5.16				

CCGW

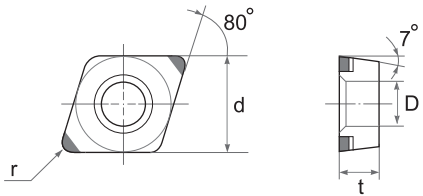

Type		Dimensions (mm)							
ISO	ASA	d	t	r	D	SBN 1000	SBN 2000	SBN 3000	SBN 4000
CCGW 09T304 M1		9.52	3.97	0.4	4.40				
CCGW 09T304 M2		9.52	3.97	0.4	4.40			●	●
CCGW 09T308 M1		9.52	3.97	0.8	4.40				
CCGW 09T308 M2		9.52	3.97	0.8	4.40			●	●

DCGW

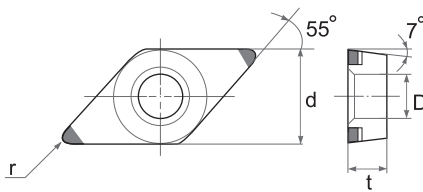

Type		Dimensions (mm)							
ISO	ASA	d	t	r	D	SBN 1000	SBN 2000	SBN 3000	SBN 4000
DCGW 11T302 M1		9.52	3.97	0.2	4.40				
DCGW 11T302 M2		9.52	3.97	0.2	4.40				
DCGW 11T304 M1		9.52	3.97	0.4	4.40				
DCGW 11T304 M2		9.52	3.97	0.4	4.40			●	●
DCGW 11T308 M1		9.52	3.97	0.8	4.40				
DCGW 11T308 M2		9.52	3.97	0.8	4.40			●	●

SNGA

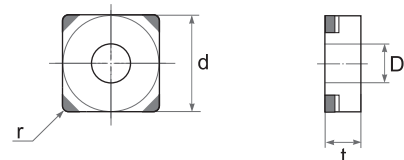

Type		Dimensions (mm)							
ISO	ASA	d	t	r	D	SBN 1000	SBN 2000	SBN 3000	SBN 4000
SNGA 120404 M1	SNGA 431 M1	12.70	4.76	0.4	5.16				
SNGA 120404 M2	SNGA 431 M2	12.70	4.76	0.4	5.16				
SNGA 120404 M4	SNGA 431 M4	12.70	4.76	0.4	5.16				
SNGA 120408 M1	SNGA 432 M1	12.70	4.76	0.8	5.16				
SNGA 120408 M2	SNGA 432 M2	12.70	4.76	0.8	5.16			●	●
SNGA 120408 M4	SNGA 432 M4	12.70	4.76	0.8	5.16			●	●

PCBN

MINI TIP

SCGW

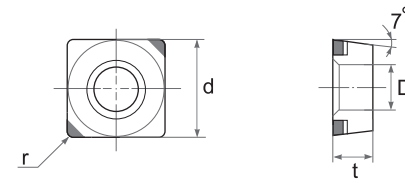

Type		Dimensions (mm)							
ISO	ASA	d	t	r	D	SBN 1000	SBN 2000	SBN 3000	SBN 4000
SCGW 09T304 M1		9.52	3.97	0.4	4.40				
SCGW 09T304 M2		9.52	3.97	0.4	4.40			●	
SCGW 09T308 M1		9.52	3.97	0.8	4.40				
SCGW 09T308 M2		9.52	3.97	0.8	4.40				

DNGA

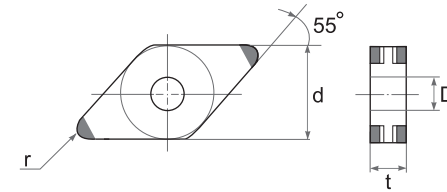

Type		Dimensions (mm)							
ISO	ASA	d	t	r	D	SBN 1000	SBN 2000	SBN 3000	SBN 4000
DNGA 150404 M1	DNGA 431 M1	12.70	4.76	0.4	5.16				
DNGA 150404 M2	DNGA 431 M2	12.70	4.76	0.4	5.16				
DNGA 150404 M4	DNGA 431 M4	12.70	4.76	0.4	5.16				
DNGA 150408 M1	DNGA 432 M1	12.70	4.76	0.8	5.16				
DNGA 150408 M2	DNGA 432 M2	12.70	4.76	0.8	5.16			●	●
DNGA 150408 M4	DNGA 432 M4	12.70	4.76	0.8	5.16			●	●
DNGA 150604 M1	DNGA 441 M1	12.70	6.35	0.4	5.16				
DNGA 150604 M2	DNGA 441 M2	12.70	6.35	0.4	5.16				
DNGA 150604 M4	DNGA 441 M4	12.70	6.35	0.4	5.16				
DNGA 150608 M1	DNGA 442 M1	12.70	6.35	0.8	5.16				
DNGA 150608 M2	DNGA 442 M2	12.70	6.35	0.8	5.16				
DNGA 150608 M4	DNGA 442 M4	12.70	6.35	0.8	5.16				

TNGA

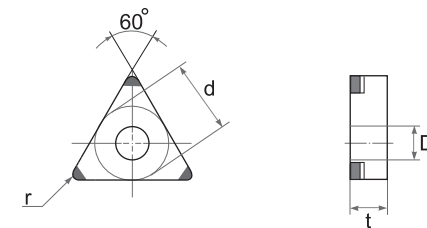

Type		Dimensions (mm)							
ISO	ASA	d	t	r	D	SBN 1000	SBN 2000	SBN 3000	SBN 4000
TNGA 160404 M1	TNGA 331 M1	9.52	4.76	0.4	3.81				
TNGA 160404 M3	TNGA 331 M3	9.52	4.76	0.4	3.81				
TNGA 160408 M1	TNGA 332 M1	9.52	4.76	0.8	3.81				
TNGA 160408 M3	TNGA 332 M3	9.52	4.76	0.8	3.81			●	●

TPGW

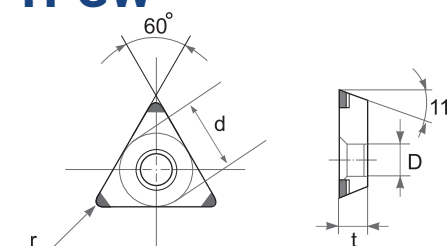

Type		Dimensions (mm)							
ISO	ASA	d	t	r	D	SBN 1000	SBN 2000	SBN 3000	SBN 4000
TPGW 160304 M1	TPGW 321 M1	9.52	3.18	0.4	4.40				
TPGW 160304 M3	TPGW 321 M3	9.52	3.18	0.4	4.40				
TPGW 160308 M1	TPGW 322 M1	9.52	3.18	0.8	4.40				
TPGW 160308 M3	TPGW 322 M3	9.52	3.18	0.8	4.40			●	●

PCBN

MINI TIP

VNGA

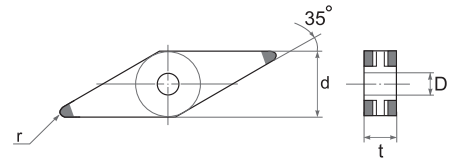

Type		Dimensions (mm)							
ISO	ASA	d	t	r	D	SBN 1000	SBN 2000	SBN 3000	SBN 4000
VNGA 160404 M1	VNGA 331 M1	9.52	4.76	0.4	3.18				
VNGA 160404 M2	VNGA 331 M2	9.52	4.76	0.4	3.18				
VNGA 160404 M4	VNGA 331 M4	9.52	4.76	0.4	3.18				
VNGA 160408 M1	VNGA 332 M1	9.52	4.76	0.8	3.18				
VNGA 160408 M2	VNGA 332 M2	9.52	4.76	0.8	3.18			●	●
VNGA 160408 M4	VNGA 332 M4	9.52	4.76	0.8	3.18			●	●

VBGW

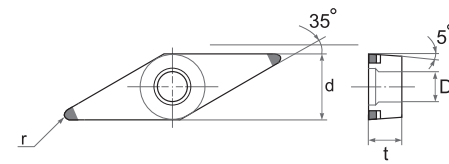

Type		Dimensions (mm)							
ISO	ASA	d	t	r	D	SBN 1000	SBN 2000	SBN 3000	SBN 4000
VBGW 160404 M1	VBGW 331 M1	9.52	4.76	0.4	4.40				
VBGW 160404 M2	VBGW 331 M2	9.52	4.76	0.4	4.40			●	●
VBGW 160408 M1	VBGW 332 M1	9.52	4.76	0.8	4.40				
VBGW 160408 M2	VBGW 332 M2	9.52	4.76	0.8	4.40			●	●

PCBN

FULL FACE

RCGX

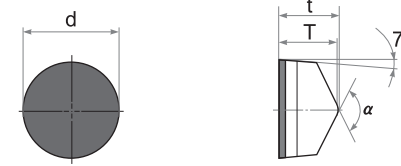

Type		Dimensions (mm)							
ISO	ASA	d	t	T	α	SBN 1000	SBN 2000	SBN 3000	SBN 4000
RCGX 060600 F	RCGX 102 F	6.35	6.35	6.20	120°	●			
RCGX 090700 F	RCGX 103 F	9.52	7.94	7.70	120°	●			
RCGX 120700 F	RCGX 104 F	12.70	7.94	7.70	120°	●			

RCGX

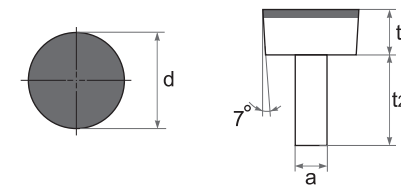

Type		Dimensions (mm)							
ISO		d	t ₁	t ₂	a	SBN 1000	SBN 2000	SBN 3000	SBN 4000
RCGX 060D F		6.35	5.00	8.35	3.00	●			
RCGX 090D F		9.52	6.00	20.00	4.00	●			
RCGX 120D F		12.70	6.00	20.00	5.88	●			

RNGN

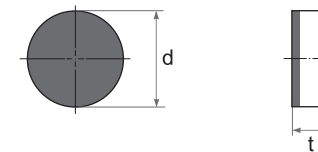

Type		Dimensions (mm)					
ISO	ASA	d	t	SBN 1000	SBN 2000	SBN 3000	SBN 4000
RNGN 090300 F	RNGN 320 F	9.52	3.18	●			
RNGN 120400 F	RNGN 430 F	12.70	4.76	●			

RPGN

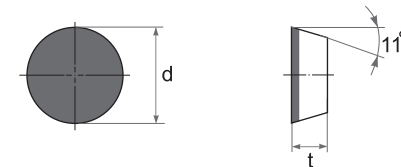

Type		Dimensions (mm)							
ISO	ASA	d	t	SBN 1000	SBN 2000	SBN 3000	SBN 4000		
RPGN 090300 F	RPGN 320 F	9.52	3.18	●					
RPGN 120300 F	RPGN 420 F	12.70	3.18	●					
RPGN 120400 F	RPGN 430 F	12.70	4.76	●					

TBGN

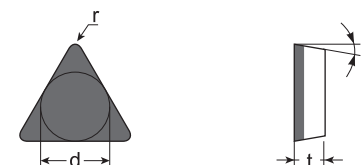

Type		Dimensions (mm)			SBN 1000	SBN 2000	SBN 3000	SBN 4000
ISO		d	t	r				
TBGN 060102 F		3.97	1.59	0.2	●	●		

PCBN

SOLID

CNGN

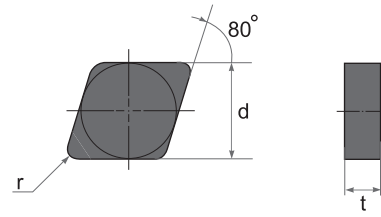

Type		Dimensions (mm)			SBN 5000
ISO	ASA	d	t	r	
CNGN 090308S	CNGN 322S	9.52	3.18	0.8	
CNGN 090312S	CNGN 323S	9.52	3.18	1.2	
CNGN 090316S	CNGN 324S	9.52	3.18	1.6	
CNGN 120408S	CNGN 432S	12.70	4.76	0.8	●
CNGN 120412S	CNGN 433S	12.70	4.76	1.2	●
CNGN 120416S	CNGN 434S	12.70	4.76	1.6	●

RNGN

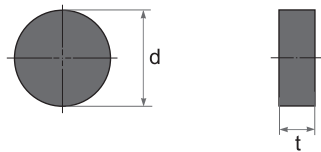

Type		Dimensions (mm)		SBN 5000
ISO	ASA	d	t	
RNGN 090300S	RNGN 320S	9.52	3.18	●
RNGN 120300S	RNGN 420S	12.70	3.18	●
RNGN 120400S	RNGN 430S	12.70	4.76	●

SNGN

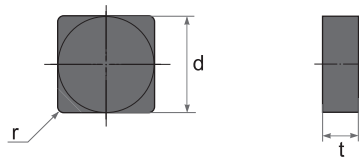

Type		Dimensions (mm)			SBN 5000
ISO	ASA	d	t	r	
SNGN 090308S	SNGN 322S	9.52	3.18	0.8	●
SNGN 090312S	SNGN 323S	9.52	3.18	1.2	●
SNGN 090316S	SNGN 324S	9.52	3.18	1.6	
SNGN 120308S	SNGN 422S	12.70	3.18	0.8	
SNGN 120312S	SNGN 423S	12.70	3.18	1.2	
SNGN 120316S	SNGN 424S	12.70	3.18	1.6	
SNGN 120408S	SNGN 432S	12.70	4.76	0.8	●
SNGN 120412S	SNGN 433S	12.70	4.76	1.2	●
SNGN 120416S	SNGN 434S	12.70	4.76	1.6	●

TNGN

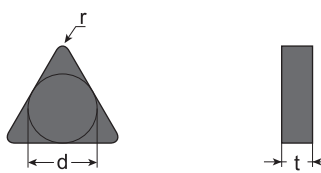

Type		Dimensions (mm)			SBN 5000
ISO	ASA	d	t	r	
TNGN 110308S	TNGN 222S	6.35	3.18	0.8	●
TNGN 110312S	TNGN 223S	6.35	3.18	1.2	●
TNGN 160408S	TNGN 332S	9.52	4.76	0.8	●
TNGN 160412S	TNGN 333S	9.52	4.76	1.2	●
TNGN 160416S	TNGN 334S	9.52	4.76	1.6	

PCBN

SOLID

CNGA

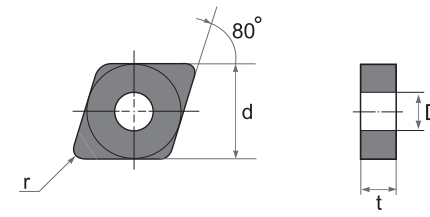

Type		Dimensions (mm)				SBN 5000
ISO	ASA	d	t	r	D	
CNGA 090308	CNGA 322	9.52	3.18	0.8	3.81	
CNGA 090312	CNGA 323	9.52	3.18	1.2	3.81	
CNGA 090316	CNGA 324	9.52	3.18	1.6	3.81	
CNGA 120408	CNGA 432	12.7	4.76	0.8	5.16	●
CNGA 120412	CNGA 433	12.7	4.76	1.2	5.16	●
CNGA 120416	CNGA 434	12.7	4.76	1.6	5.16	●

RNGA

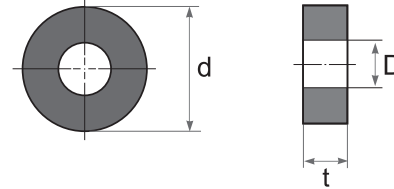

Type		Dimensions (mm)				SBN 5000
ISO	ASA	d	t	r	D	
RNGA 060300	RNGA 060300	6.35	3.18	-	2.26	
RNGA 060400	RNGA 060400	6.35	4.76	-	2.26	
RNGA 090300	RNGA 090300	9.52	3.18	-	3.81	
RNGA 120300	RNGA 120300	12.7	3.18	-	5.16	
RNGA 120400	RNGA 120400	12.7	4.76	-	5.16	●

SNGA

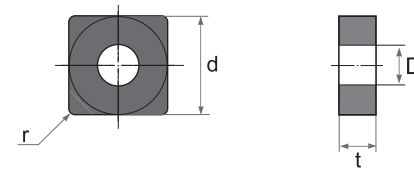

Type		Dimensions (mm)				SBN 5000
ISO	ASA	d	t	r	D	
SNGA 090308	SNGA 322	9.52	3.18	0.8	3.81	
SNGA 090312	SNGA 323	9.52	3.18	1.2	3.81	
SNGA 090316	SNGA 324	9.52	3.18	1.6	3.81	
SNGA 120308	SNGA 422	9.52	3.18	0.8	5.16	
SNGA 120312	SNGA 423	9.52	3.18	1.2	5.16	
SNGA 120316	SNGA 424	9.52	3.18	1.6	5.16	
SNGA 120408	SNGA 432	12.7	4.76	0.8	5.16	●
SNGA 120412	SNGA 433	12.7	4.76	1.2	5.16	●
SNGA 120416	SNGA 434	12.7	4.76	1.6	5.16	●

TNGA

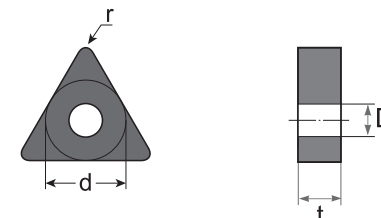

Type		Dimensions (mm)				SBN 5000
ISO	ASA	d	t	r	D	
TNGA 110308	TNGA 222	6.35	3.18	0.8	2.26	
TNGA 110312	TNGA 223	6.35	3.18	1.2	2.26	
TNGA 110316	TNGA 224	6.35	3.18	1.6	2.26	
TNGA 160408	TNGA 332	9.52	4.76	0.8	3.81	●
TNGA 160412	TNGA 333	9.52	4.76	1.2	3.81	●
TNGA 160416	TNGA 334	9.52	4.76	1.6	3.81	●

PCD

STANDARD

CNGA

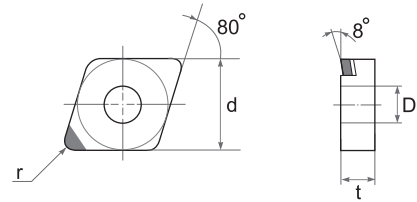

Type		Dimensions (mm)						
ISO	ASA	d	t	r	D	SPD 1000	SPD 2000	SPD 3000
CNGA 120404 R1	CNGA 431 R1	12.70	4.76	0.4	5.16		●	
CNGA 120408 R1	CNGA 432 R1	12.70	4.76	0.8	5.16	●	●	
CNGA 120412 R1	CNGA 433 R1	12.70	4.76	1.2	5.16			

CCGW

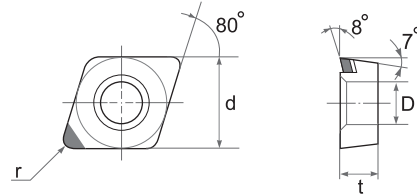

Type		Dimensions (mm)						
ISO		d	t	r	D	SPD 1000	SPD 2000	SPD 3000
CCGW 060202 R1		6.35	2.38	0.2	2.80			
CCGW 060204 R1		6.35	2.38	0.4	2.80		●	
CCGW 060208 R1		6.35	2.38	0.8	2.80		●	
CCGW 09T302 R1		9.52	3.97	0.2	4.40			
CCGW 09T304 R1		9.52	3.97	0.4	4.40	●	●	
CCGW 09T308 R1		9.52	3.97	0.8	4.40		●	
CCGW 120404 R1		12.70	4.76	0.4	5.50		●	
CCGW 120408 R1		12.70	4.76	0.8	5.50		●	
CCGW 120412 R1		12.70	4.76	1.2	5.50			

CPGW

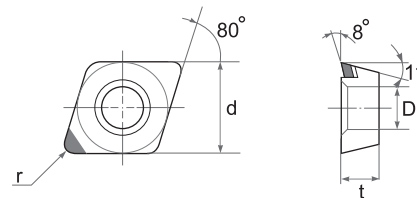

Type		Dimensions (mm)						
ISO		d	t	r	D	SPD 1000	SPD 2000	SPD 3000
CPGW 080204 R1		7.94	2.38	0.4	3.40			
CPGW 080208 R1		7.94	2.38	0.8	3.40			
CPGW 080212 R1		7.94	2.38	1.2	3.40			
CPGW 090304 R1		9.525	3.18	0.4	4.40			
CPGW 090308 R1		9.525	3.18	0.8	4.40			
CPGW 090312 R1		9.525	3.18	1.2	4.40			

DNGA

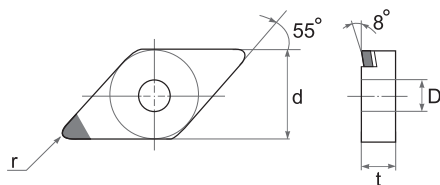

Type		Dimensions (mm)						
ISO	ASA	d	t	r	D	SPD 1000	SPD 2000	SPD 3000
DNGA 150404 R1	DNGA 431 R1	12.70	4.76	0.4	5.16	●	●	
DNGA 150408 R1	DNGA 432 R1	12.70	4.76	0.8	5.16	●	●	
DNGA 150412 R1	DNGA 433 R1	12.70	4.76	1.2	5.16		●	
DNGA 150604 R1	DNGA 441 R1	12.70	6.35	0.4	5.16	●	●	
DNGA 150608 R1	DNGA 442 R1	12.70	6.35	0.8	5.16	●	●	
DNGA 150612 R1	DNGA 443 R1	12.70	6.35	1.2	5.16		●	

PCD

STANDARD

DCGW

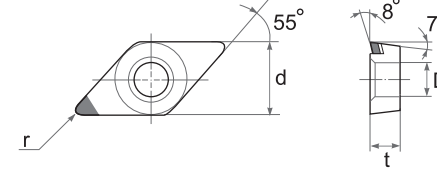

Type		Dimensions (mm)						
ISO		d	t	r	D	SPD 1000	SPD 2000	SPD 3000
DCGW 070202 R1		6.35	2.38	0.2	2.80			
DCGW 070204 R1		6.35	2.38	0.4	2.80	●	●	
DCGW 070208 R1		6.35	2.38	0.8	2.80		●	
DCGW 11T302 R1		9.52	3.97	0.2	4.40			
DCGW 11T304 R1		9.52	3.97	0.4	4.40	●	●	
DCGW 11T308 R1		9.52	3.97	0.8	4.40		●	

SNGA

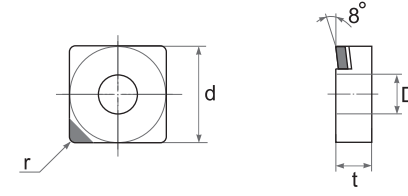

Type		Dimensions (mm)						
ISO	ASA	d	t	r	D	SPD 1000	SPD 2000	SPD 3000
SNGA 120404 R1	SNGA 431 R1	12.70	4.76	0.4	5.16	●	●	
SNGA 120408 R1	SNGA 432 R1	12.70	4.76	0.8	5.16		●	
SNGA 120412 R1	SNGA 433 R1	12.70	4.76	1.2	5.16			

SNGN

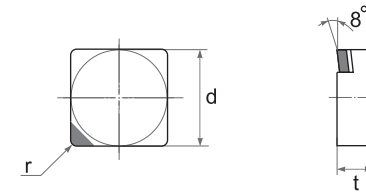

Type		Dimensions (mm)						
ISO	ASA	d	t	r	D	SPD 1000	SPD 2000	SPD 3000
SNGN 120404 R1	SNGN 431 R1	12.70	4.76	0.4		●	●	
SNGN 120408 R1	SNGN 432 R1	12.70	4.76	0.8			●	
SNGN 120412 R1	SNGN 433 R1	12.70	4.76	1.2				

SCGW

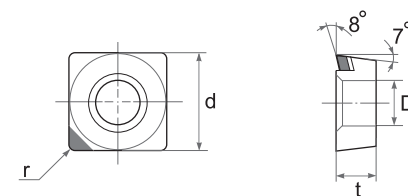

Type		Dimensions (mm)						
ISO		d	t	r	D	SPD 1000	SPD 2000	SPD 3000
SCGW 09T304 R1		9.52	3.97	0.4	4.40	●	●	
SCGW 09T308 R1		9.52	3.97	0.8	4.40		●	
SCGW 09T312 R1		9.52	3.97	1.2	4.40			
SCGW 120402 R1		12.70	4.76	0.2	5.50			
SCGW 120404 R1		12.70	4.76	0.4	5.50	●	●	
SCGW 120408 R1		12.70	4.76	0.8	5.50		●	

PCD

STANDARD

SPGN

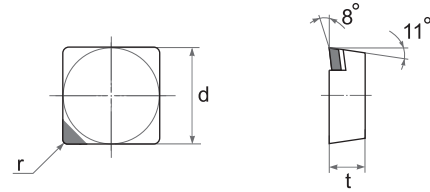

Type		Dimensions (mm)					
ISO	ASA	d	t	r	SPD 1000	SPD 2000	SPD 3000
SPGN 090304 R1	SPGN 321 R1	9.52	3.18	0.4			
SPGN 090308 R1	SPGN 322 R1	9.52	3.18	0.8		●	
SPGN 120304 R1	SPGN 421 R1	12.70	3.18	0.4			
SPGN 120308 R1	SPGN 422 R1	12.70	3.18	0.8		●	

SPGW

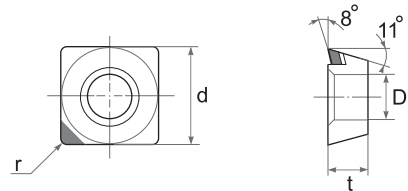

Type		Dimensions (mm)					
ISO	ASA	d	t	r	SPD 1000	SPD 2000	SPD 3000
SPGW 090302 R1	SPGW 3202 R1	9.52	3.18	0.2			
SPGW 090304 R1	SPGW 321 R1	9.52	3.18	0.4			
SPGW 090308 R1	SPGW 322 R1	9.52	3.18	0.8			

TNGA

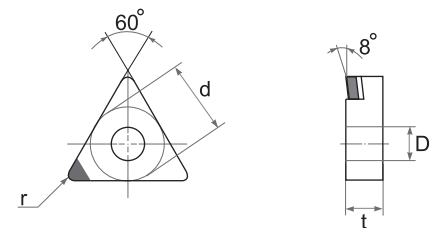

Type		Dimensions (mm)						
ISO	ASA	d	t	r	D	SPD 1000	SPD 2000	SPD 3000
TNGA 160402 R1	TNGA 3302 R1	9.52	4.76	0.2	3.81		●	
TNGA 160404 R1	TNGA 331 R1	9.52	4.76	0.4	3.81	●	●	
TNGA 160408 R1	TNGA 332 R1	9.52	4.76	0.8	3.81		●	
TNGA 160412 R1	TNGA 333 R1	9.52	4.76	1.2	3.81			

TBGW

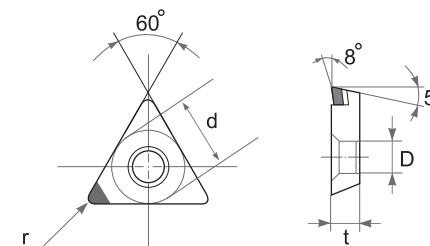

Type		Dimensions (mm)					
ISO	d	t	r	D	SPD 1000	SPD 2000	SPD 3000
TBGW 060102 R1	3.97	1.59	0.2	2.80			
TBGW 060104 R1	3.97	1.59	0.4	2.80			

PCD

STANDARD

TCGW

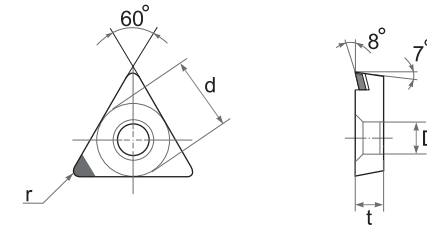

Type		Dimensions (mm)					
ISO	d	t	r	D	SPD 1000	SPD 2000	SPD 3000
TCGW 090202 R1	5.56	2.38	0.2	2.5			
TCGW 090204 R1	5.56	2.38	0.4	2.5	●	●	
TCGW 090208 R1	5.56	2.38	0.8	2.5		●	
TCGW 110202 R1	6.35	2.38	0.2	2.8			
TCGW 110204 R1	6.35	2.38	0.4	2.8	●	●	
TCGW 110208 R1	6.35	2.38	0.8	2.8		●	
TCGW 16T302 R1	9.52	3.97	0.2	4.4			
TCGW 16T304 R1	9.52	3.97	0.4	4.4	●	●	
TCGW 16T308 R1	9.52	3.97	0.8	4.4		●	

TPGN

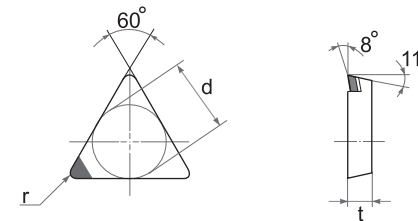

Type		Dimensions (mm)					
ISO	ASA	d	t	r	SPD 1000	SPD 2000	SPD 3000
TPGN 090204 R1	TPGN 721 R1	5.56	2.38	0.4			
TPGN 090208 R1	TPGN 732 R1	5.56	2.38	0.8			
TPGN 110302 R1	TPGN 2202 R1	6.35	3.18	0.2	●	●	●
TPGN 110304 R1	TPGN 221 R1	6.35	3.18	0.4	●	●	●
TPGN 110308 R1	TPGN 222 R1	6.35	3.18	0.8	●	●	●
TPGN 160302 R1	TPGN 3202 R1	9.52	3.18	0.2	●	●	●
TPGN 160304 R1	TPGN 321 R1	9.52	3.18	0.4	●	●	●
TPGN 160308 R1	TPGN 322 R1	9.52	3.18	0.8	●	●	●

TPGB

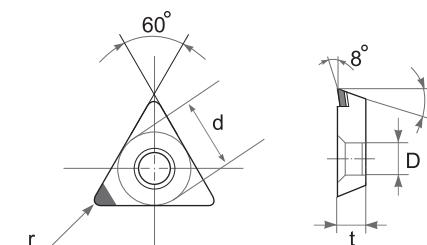

Type		Dimensions (mm)					
ISO	d	t	r	D	SPD 1000	SPD 2000	SPD 3000
TPGB 080204 R1	4.76	2.38	0.4	2.40			
TPGB 080208 R1	4.76	2.38	0.8	2.40			
TPGB 090204 R1	5.56	2.38	0.4	2.50			
TPGB 090208 R1	5.56	2.38	0.8	2.50			
TPGB 110304 R1	6.35	3.18	0.4	3.30		●	
TPGB 110308 R1	6.35	3.18	0.8	3.30		●	

PCD

STANDARD

TPGW

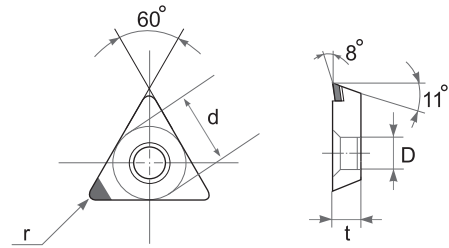

Type		Dimensions (mm)						
ISO		d	t	r	D	SPD 1000	SPD 2000	SPD 3000
TPGW 080202 R1		4.76	2.38	0.2	2.40		●	
TPGW 080204 R1		4.76	2.38	0.4	2.40		●	
TPGW 110302 R1		6.35	3.18	0.2	3.30			
TPGW 110304 R1		6.35	3.18	0.4	3.30		●	
TPGW 110308 R1		6.35	3.18	0.8	3.30			
TPGW 160404 R1		9.52	4.76	0.4	3.81			
TPGW 160408 R1		9.52	4.76	0.8	3.81			

TPGT

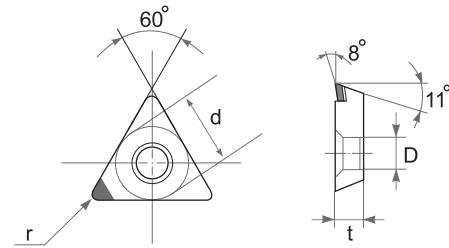

Type		Dimensions (mm)						
ISO		d	t	r	D	SPD 1000	SPD 2000	SPD 3000
TPGT 110302 R1		6.35	3.18	0.2	3.40			
TPGT 110304 R1		6.35	3.18	0.4	3.40			

VNGA

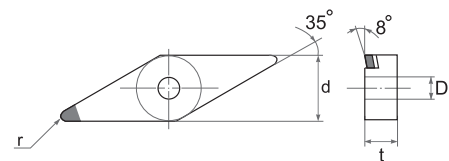

Type		Dimensions (mm)						
ISO	ASA	d	t	r	D	SPD 1000	SPD 2000	SPD 3000
VNGA 160404 R1	VNGA 331 R1	9.52	4.76	0.4	3.18	●	●	
VNGA 160408 R1	VNGA 332 R1	9.52	4.76	0.8	3.18		●	

VBGW

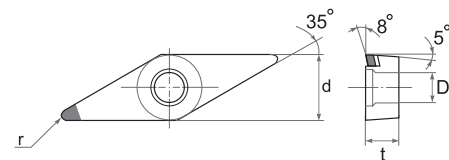

Type		Dimensions (mm)						
ISO	ASA	d	t	r	D	SPD 1000	SPD 2000	SPD 3000
VBGW 110302 R1	VBGW 2202 R1	6.35	3.18	0.2	3.40			
VBGW 110304 R1	VBGW 221 R1	6.35	3.18	0.4	3.40			
VBGW 110308 R1	VBGW 222 R1	6.35	3.18	0.8	3.40			
VBGW 160402 R1	VBGW 3302 R1	9.52	4.76	0.2	4.40			
VBGW 160404 R1	VBGW 331 R1	9.52	4.76	0.4	4.40	●	●	
VBGW 160408 R1	VBGW 332 R1	9.52	4.76	0.8	4.40		●	
VBGW 160412 R1	VBGW 333 R1	9.52	4.76	1.2	4.40			

PCD

STANDARD

VCGW

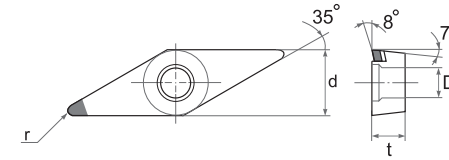

Type		Dimensions (mm)						
ISO	ASA	d	t	r	D	SPD 1000	SPD 2000	SPD 3000
VCGW 110302 R1	VCGW 2202 R1	6.35	3.18	0.2	2.80	●		
VCGW 110304 R1	VCGW 221 R1	6.35	3.18	0.4	3.40	●		
VCGW 110308 R1	VCGW 222 R1	6.35	3.18	0.8	3.40			
VCGW 160404 R1	VCGW 331 R1	9.52	4.76	0.4	4.40			
VCGW 160408 R1	VCGW 332 R1	9.52	4.76	0.8	4.40			
VCGW 160412 R1	VCGW 333 R1	9.52	4.76	1.2	4.40			

TCGW/TPGW .. FS

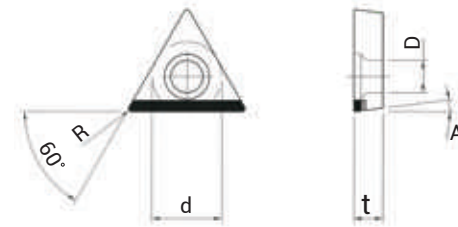

Type	Dimensions (mm)					PCBN				PCD				
	ISO	d	t	A	D	r	SBN 1000	SBN 2000	SBN 3000	SBN 4000	SPD 1000	SPD 2000	SPD 3000	SPD 4000
TCGW 0902..FS	6.35	2.38	7°	2.3	0.2 0.4 0.8		●				●			
TCGW 1102..FS	6.35	2.38	7°	2.8	0.2 0.4 0.8		●				●			
TPGW 1103..FS	6.35	2.38	11°	3.3	0.2 0.4 0.8		●				●			

CCGW .. FS

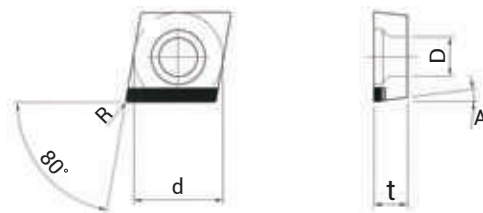

Type	Dimensions (mm)					PCBN				PCD				
	ISO	d	t	A	D	r	SBN 1000	SBN 2000	SBN 3000	SBN 4000	SPD 1000	SPD 2000	SPD 3000	SPD 4000
CCGW 0602..FS	6.35	2.38	7°	2.8	0.2 0.4 0.8		●				●			
CCGW 09T3..FS	9.52	3.97	7°	4.4	0.2 0.4 0.8		●				●			
CCGW 1204..FS	12.70	4.76	7°	5.5	0.2 0.4 0.8		●				●			

SCGW .. FS

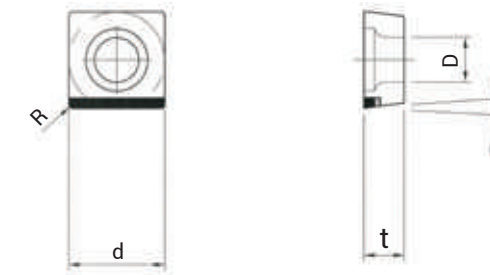

Type	Dimensions (mm)					PCBN				PCD				
	ISO	d	t	A	D	r	SBN 1000	SBN 2000	SBN 3000	SBN 4000	SPD 1000	SPD 2000	SPD 3000	SPD 4000
SCGW 0602..FS	6.35	2.38	7°	2.8	0.2 0.4 0.8		●					●		
SCGW 09T3..FS	9.52	3.97	7°	4.4	0.2 0.4 0.8		●					●		
SCGW 1204..FS	12.70	4.76	7°	5.60	0.4 0.8		●					●		

SPGW .. FS

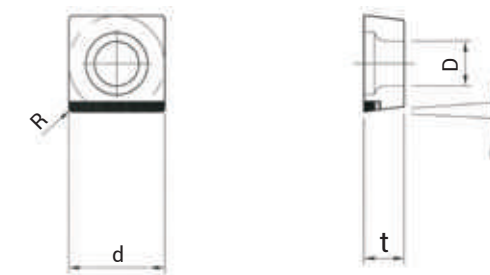

Type	Dimensions (mm)					PCBN				PCD				
	ISO	d	t	A	D	R	SBN 1000	SBN 2000	SBN 3000	SBN 4000	SPD 1000	SPD 2000	SPD 3000	SPD 4000
SPGW 09T3..FS	9.52	3.97	11°	4.4	0.2 0.4 0.8 1.2		●					●		
SPGW 1204..FS	12.70	4.76	11°	4.4	0.2 0.4 0.8 1.2		●					●		

SPCN

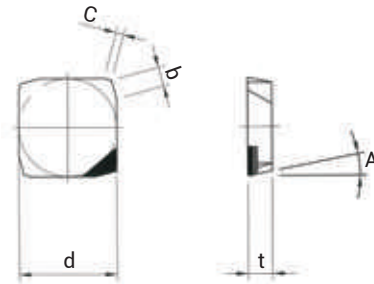

Type	Dimensions (mm)					PCBN				PCD				
	ISO	d	t	A	b	c	SBN 1000	SBN 2000	SBN 3000	SBN 4000	SPD 1000	SPD 2000	SPD 3000	SPD 4000
SPCN 1203EDR/L	12.7	3.18	11°	1.4	1									

SPKN

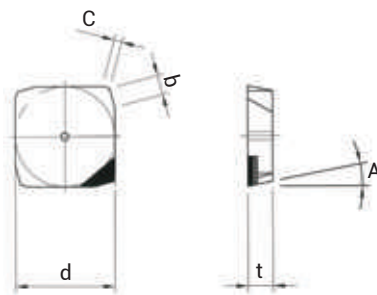

Type	Dimensions (mm)					PCBN				PCD				
	ISO	d	t	A	b	c	SBN 1000	SBN 2000	SBN 3000	SBN 4000	SPD 1000	SPD 2000	SPD 3000	SPD 4000
SPCN 1203EDSR	12.7	3.18	11°	1.87	0.86									

SFCN

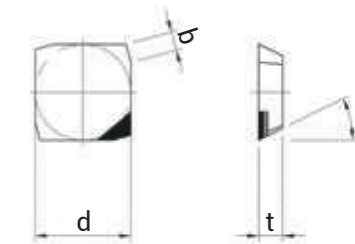

Type	Dimensions (mm)				PCBN				PCD				
	ISO	d	t	A	b	SBN 1000	SBN 2000	SBN 3000	SBN 4000	SPD 1000	SPD 2000	SPD 3000	SPD 4000
SFCN 1203EFR	12.7	3.18	26°	2.5									

TPCN

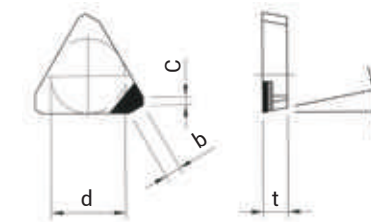

Type	Dimensions (mm)					PCBN				PCD				
	ISO	d	t	A	b	c	SBN 1000	SBN 2000	SBN 3000	SBN 4000	SPD 1000	SPD 2000	SPD 3000	SPD 4000
TPCN 1603PPN	9.525	3.18	11°	1.2	1.2									
TPCN 1603PPR	9.525	3.18	11°	1.2	1									
TPCN 2204PDR	12.7	4.76	11°	1.4	0.7									

UGMR

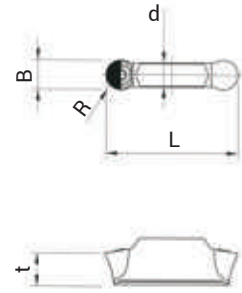

Type	Dimensions (mm)					PCBN				PCD				
	B	R	L	d	t	SBN 1000	SBN 2000	SBN 3000	SBN 4000	SPD 1000	SPD 2000	SPD 3000	SPD 4000	
UGMR	300N-R1.5	3.0	1.5	21.0	2.4	4.8		●				●		
	400N-R2.0	4.0	2.0	21.0	3.3	4.8		●				●		
	500N-R2.5	5.0	2.5	26.0	4.1	5.8		●				●		

UGMT

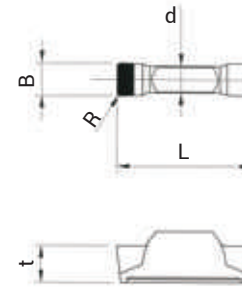

Type	Dimensions (mm)					PCBN				PCD				
	B	R	L	d	t	SBN 1000	SBN 2000	SBN 3000	SBN 4000	SPD 1000	SPD 2000	SPD 3000	SPD 4000	
UGMT	300N-R0.2	3.0	0.2	21.0	2.4	4.8		●				●		
	300N-R0.4	3.0	0.4	21.0	2.4	4.8		●				●		
	400N-R0.2	4.0	2.5	26.0	3.3	4.8		●				●		
	400N-R0.4	4.0	1.5	21.0	3.3	4.8		●				●		
	500N-R0.2	5.0	2.0	26.0	4.1	5.8		●				●		
	500N-R0.4	5.0	2.5	26.0	4.1	5.8		●				●		

UTGR/L

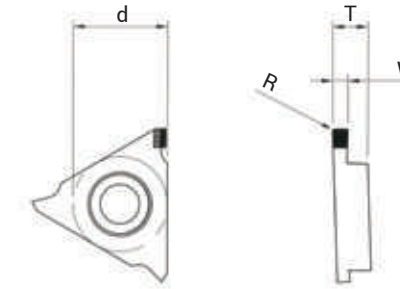

Type	Dimensions (mm)				PCBN				PCD				
	d	T	W	R	SBN 1000	SBN 2000	SBN 3000	SBN 4000	SPD 1000	SPD 2000	SPD 3000	SPD 4000	
UTGR/L	121002	12.70	4.76	1.0	0.2		●				●		
	121004	12.70	4.76	1.0	0.4		●				●		
	121502	12.70	4.76	1.5	0.2		●				●		
	121504	12.70	4.76	1.5	0.4		●				●		
	122002	12.70	4.76	2.0	0.2		●				●		
	122004	12.70	4.76	2.0	0.4		●				●		
	122502	12.70	4.76	2.5	0.2		●				●		
	122504	12.70	4.76	2.5	0.4		●				●		
	123002	12.70	4.76	3.0	0.2		●				●		
	123004	12.70	4.76	3.0	0.4		●				●		

※ W : Min. 0.8mm ~ Max. 3.5mm
R : Min. 0.05R ~ Max. 1.75R

NOTCH BITE

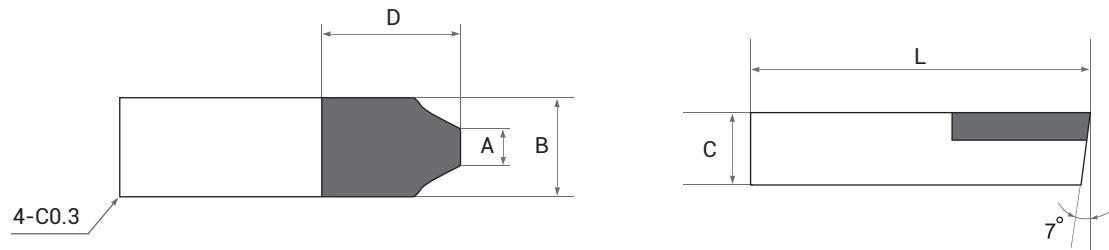

Type	Dimensions (mm)					SBN1000	SPD3000
	A	B	C	D	L		
BITE SD-10	0.80	3.0	2.50	4.0	8.6		
BITE SD-13	0.80	3.5	3.50	4.5	11.5		
BITE SD-16	1.00	5.0	4.00	6.0	14.4		
BITE SD-19	1.00	6.0	4.50	8.0	16.5		
BITE SD-22	1.20	10.0	6.00	10.0	21.0		
BITE SD-25	1.60	10.0	6.00	10.0	24.0		
BITE SD-29	1.70	11.3	6.00	10.0	28.5		
BITE SD-32	1.70	11.3	6.00	10.0	30.0		
BITE SD-35	2.02	12.5	6.00	10.0	33.0		
BITE SD-38	2.39	15.0	6.50	10.0	36.0		
BITE SD-51	4.28	20.0	8.00	10.0	49.0		
BITE SD-57	2.92	22.0	8.00	10.0	56.0		

SFE .. 1C

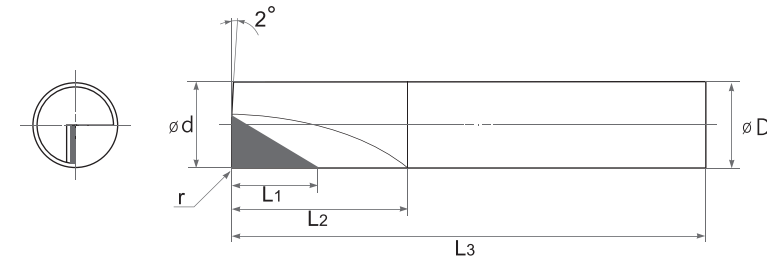

Type	Dimensions (mm)						PCBN				PCD			
	ISO	d	D	L ₁	L ₂	L ₃	r	SBN 1000	SBN 2000	SBN 3000	SBN 4000	SPD 1000	SPD 2000	SPD 3000
SFE 250-1C		2.0	4.0	4.0	10.0	50.0	0.15						●	
SFE 280-1C		2.0	4.0	4.0	10.0	80.0	0.15						●	
SFE 350-1C		3.0	4.0	4.0	10.0	50.0	0.15						●	
SFE 380-1C		3.0	4.0	4.0	10.0	80.0	0.15						●	
SFE 450-1C		4.0	4.0	6.0	12.0	50.0	0.20						●	
SFE 480-1C		4.0	4.0	6.0	12.0	80.0	0.20						●	
SFE 650-1C		6.0	6.0	6.0	16.0	50.0	0.20						●	
SFE 6100-1C		6.0	6.0	6.0	16.0	100.0	0.20						●	
SFE 860-1C		8.0	8.0	7.0	16.0	60.0	0.40						●	
SFE 8120-1C		8.0	8.0	7.0	16.0	120.0	0.40						●	
SFE 1070-1C		10.0	10.0	7.0	16.0	70.0	0.40						●	
SFE 10120-1C		10.0	10.0	7.0	16.0	120.0	0.40						●	

SFE .. 2C

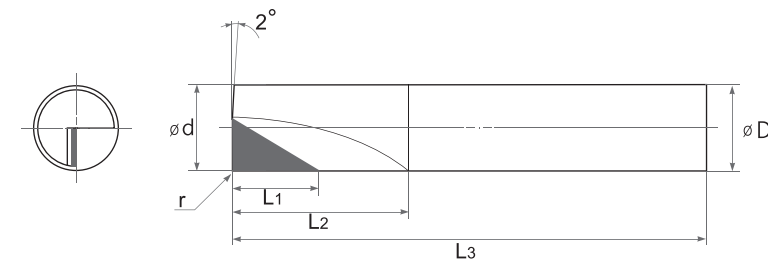

Type	Dimensions (mm)						PCBN				PCD			
	ISO	d	D	L ₁	L ₂	L ₃	r	SBN 1000	SBN 2000	SBN 3000	SBN 4000	SPD 1000	SPD 2000	SPD 3000
SFE 650-2C		6.0	6.0	4.0	12.0	50.0	0.20						●	
SFE 680-2C		6.0	6.0	6.0	16.0	80.0	0.20						●	
SFE 860-2C		8.0	8.0	7.0	16.0	60.0	0.20						●	
SFE 8120-2C		8.0	8.0	9.0	20.0	120.0	0.40						●	
SFE 1070-2C		10.0	10.0	9.0	20.0	70.0	0.40						●	
SFE 10120-2C		10.0	10.0	12.0	25.0	120.0	0.80						●	
SFE 1270-2C		12.0	12.0	12.0	25.0	70.0	0.80						●	
SFE 12120-2C		12.0	12.0	16.0	30.0	120.0	1.00						●	
SFE 16100-2C		16.0	16.0	16.0	25.0	100.0	0.80						●	
SFE 16150-2C		16.0	16.0	20.0	30.0	150.0	1.00						●	
SFE 18100-2C		18.0	18.0	20.0	30.0	100.0	0.80						●	
SFE 18200-2C		18.0	18.0	24.0	35.0	200.0	1.20						●	
SFE 20100-2C		20.0	20.0	24.0	35.0	100.0	0.80						●	
SFE 20200-2C		20.0	20.0	28.0	40.0	200.0	1.20						●	

SPECIAL

ENDMILL

SBE .. 1C

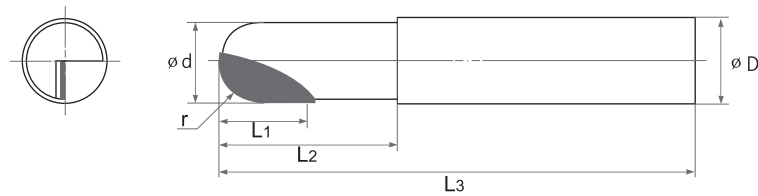

Type	Dimensions (mm)						PCBN				PCD			
	ISO	d	D	L ₁	L ₂	L ₃	r	SBN 1000	SBN 2000	SBN 3000	SBN 4000	SPD 1000	SPD 2000	SPD 3000
SBE 250-1C	2.0	4.0	4.0	12.0	50.0	1.0								
SBE 280-1C	2.0	4.0	4.0	16.0	80.0	1.0								
SBE 350-1C	3.0	4.0	4.0	16.0	50.0	1.5						●		
SBE 380-1C	3.0	4.0	6.0	30.0	80.0	1.5						●		
SBE 450-1C	4.0	4.0	4.0	16.0	50.0	2.0						●		
SBE 480-1C	4.0	4.0	6.0	40.0	80.0	2.0						●		
SBE 650-1C	6.0	6.0	6.0	20.0	50.0	3.0						●		
SBE 6100-1C	6.0	6.0	8.0	50.0	100.0	3.0						●		
SBE 860-1C	8.0	8.0	8.0	30.0	60.0	4.0						●		
SBE 8120-1C	8.0	8.0	10.0	60.0	120.0	4.0						●		
SBE 1080-1C	10.0	10.0	10.0	30.0	80.0	5.0						●		
SBE 10160-1C	10.0	10.0	12.0	60.0	160.0	5.0						●		
SBE 12100-1C	12.0	12.0	12.0	40.0	100.0	6.0						●		
SBE 12200-1C	12.0	12.0	16.0	80.0	200.0	6.0						●		
SBE 16160-1C	16.0	16.0	16.0	60.0	160.0	8.0						●		
SBE 16250-1C	16.0	16.0	20.0	100.0	250.0	8.0						●		

SBE .. 2C

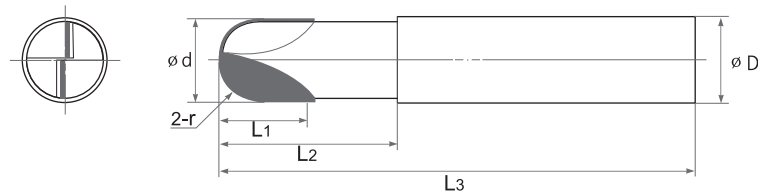

Type	Dimensions (mm)						PCBN				PCD			
	ISO	d	D	L ₁	L ₂	L ₃	r	SBN 1000	SBN 2000	SBN 3000	SBN 4000	SPD 1000	SPD 2000	SPD 3000
SBE 650-2C	6.0	6.0	6.0	20.0	50.0	3.0								
SBE 6100-2C	6.0	6.0	8.0	50.0	100.0	3.0								
SBE 860-2C	8.0	8.0	8.0	30.0	60.0	4.0						●		
SBE 8120-2C	8.0	8.0	10.0	60.0	120.0	4.0						●		
SBE 1080-2C	10.0	10.0	10.0	30.0	80.0	5.0						●		
SBE 10160-2C	10.0	10.0	12.0	60.0	160.0	5.0						●		
SBE 12100-2C	12.0	12.0	12.0	40.0	100.0	6.0						●		
SBE 12200-2C	12.0	12.0	16.0	80.0	200.0	6.0						●		

SPECIAL

HSK - TOOL

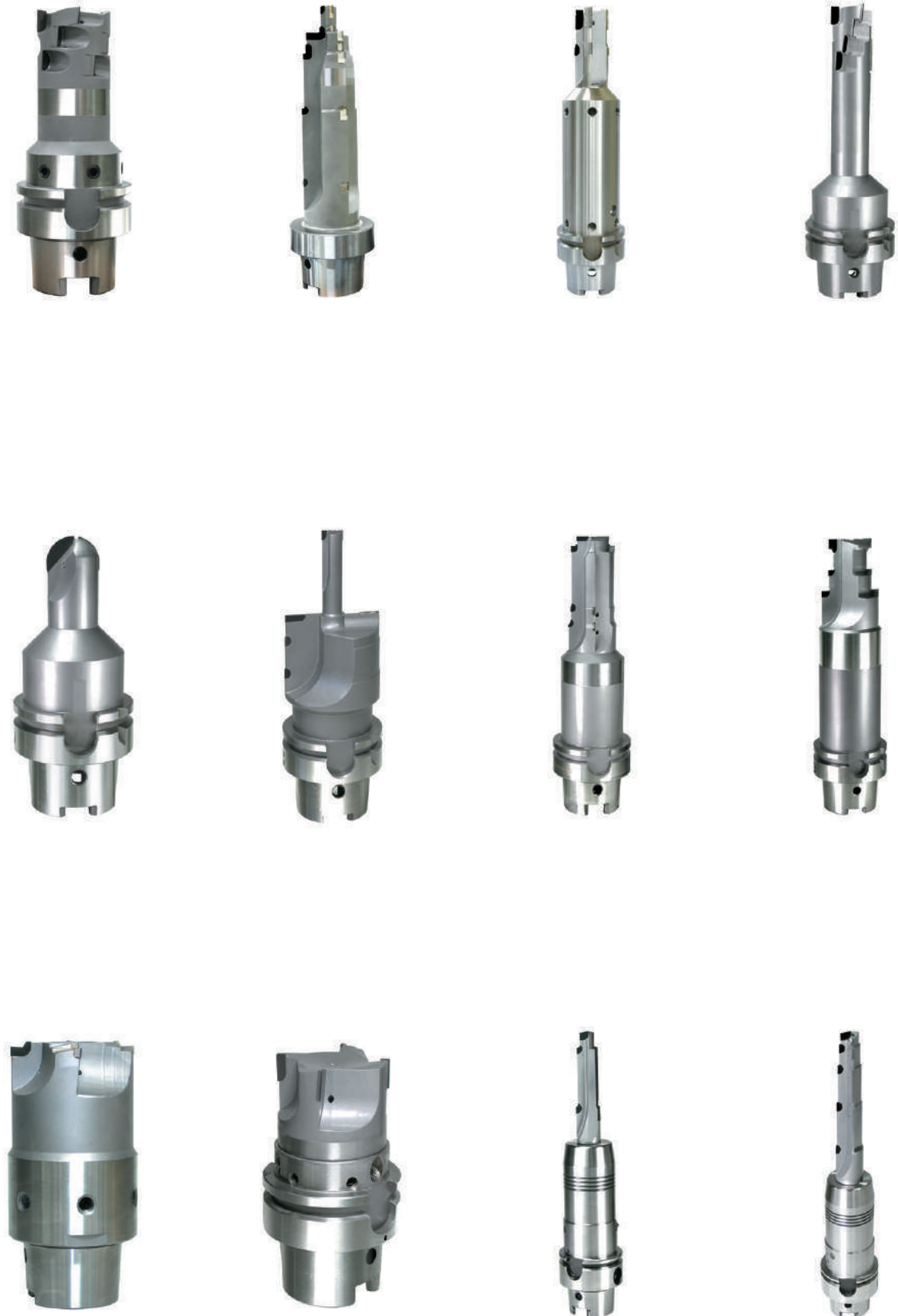

SPECIAL

PCD ENDMILL

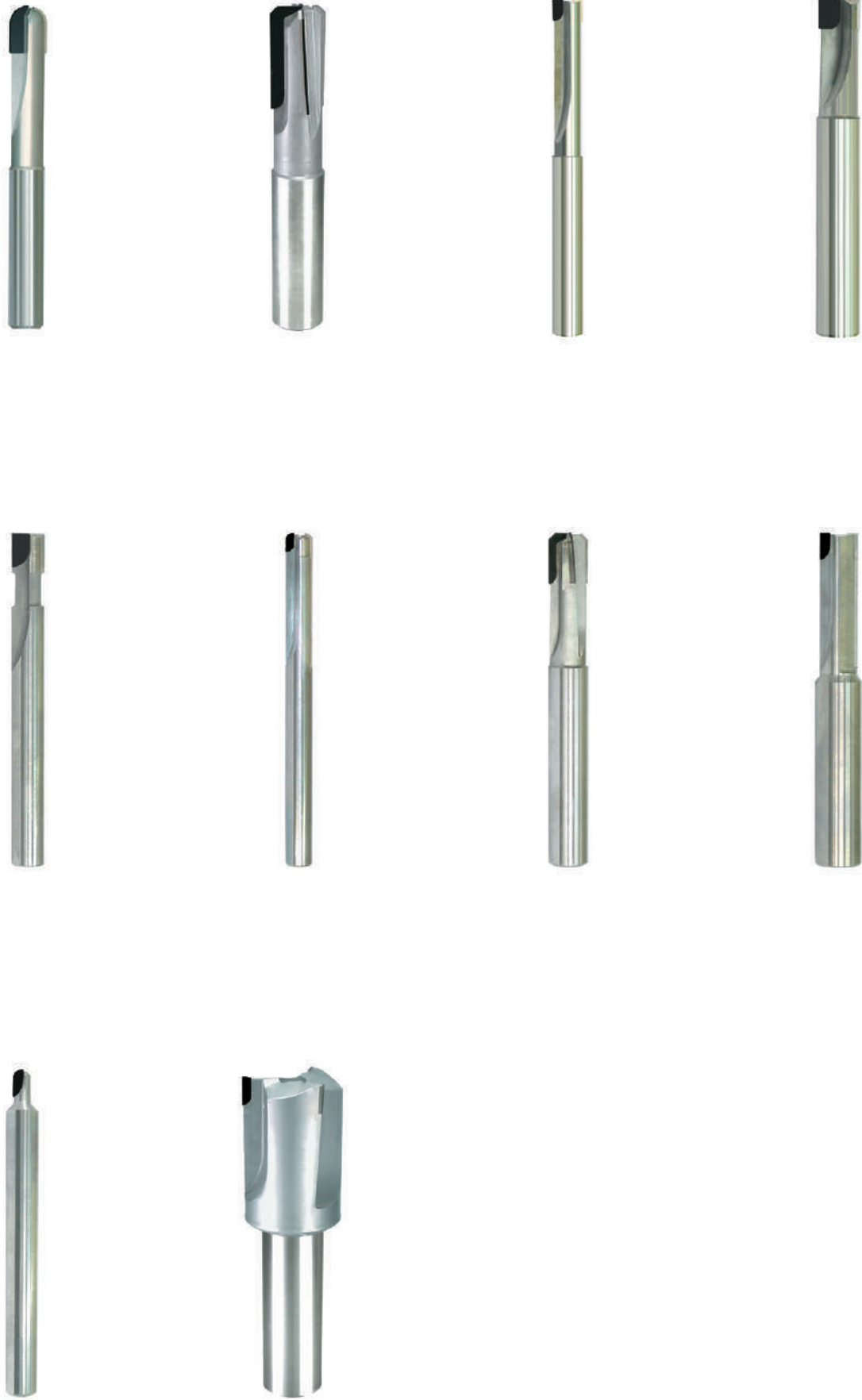

SPECIAL

PCD DRILL / GUN REAMER



TOOL HOLDER

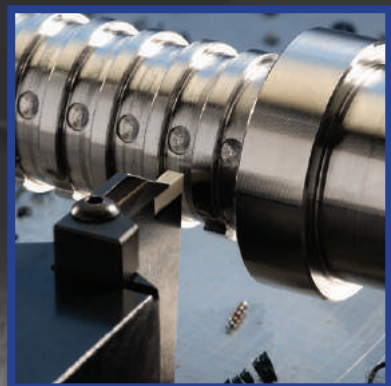

APPLICATION INDEX	A 140
IDENTIFICATION SYSTEM	A 142
EXTERNAL TOOLHOLDER	A 144
SPECIAL	A 181

APPLICATION INDEX

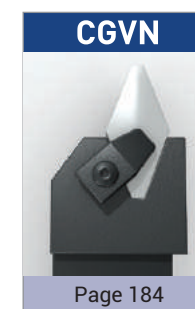
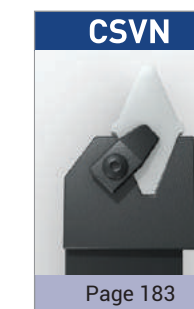
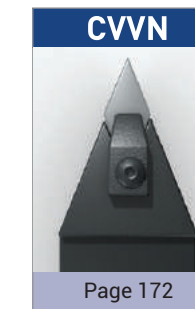

IDENTIFICATION SYSTEM

C
1 **C**
2 **L**
3 **N**
4 **R**
5 **25**
6

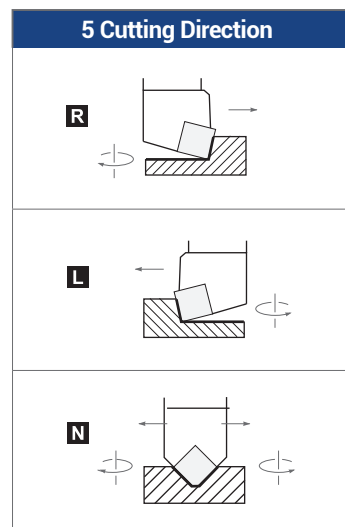
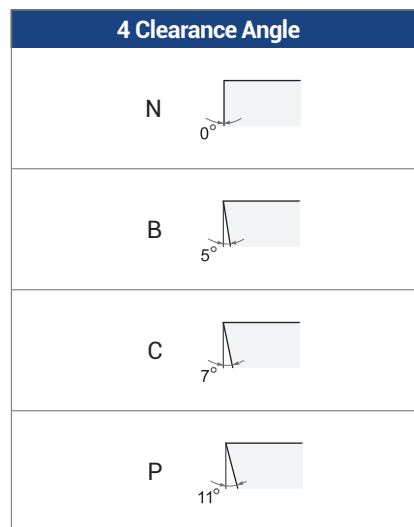
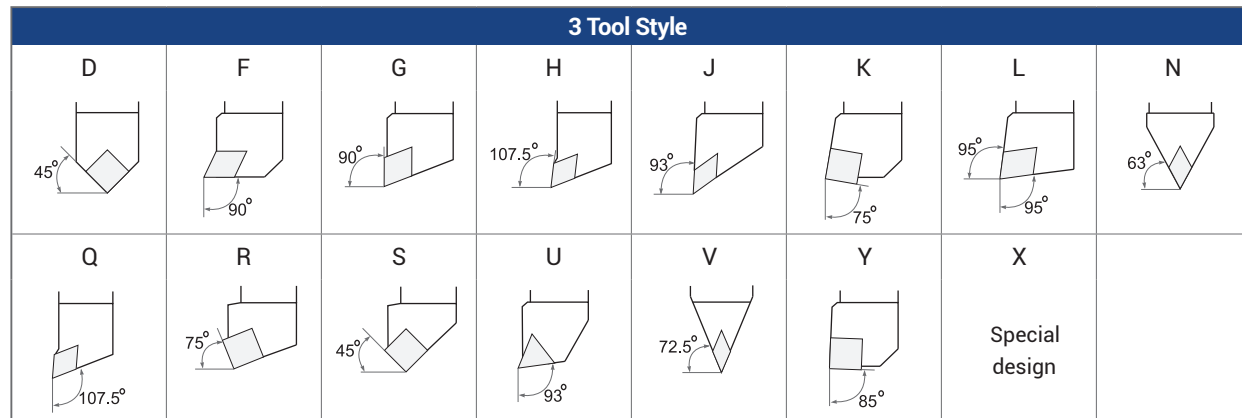
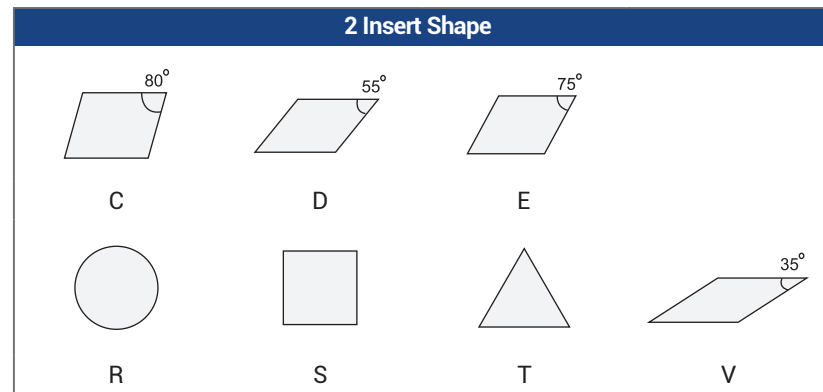
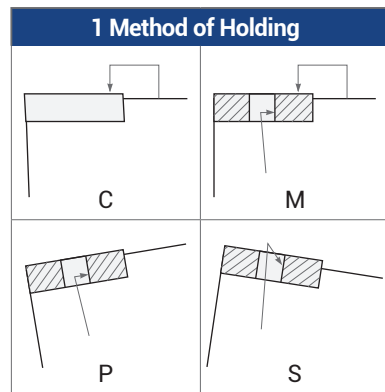

6 Tool Height (h=h₁)

h (mm)	h (mm)
12	12
16	16
20	20
25	25
32	32
40	40
50	50

25
7 **M**
8 **12**
9 -
10 **A**
11 **7**
11

7 Tool Width (d)

d (mm)	d (mm)
12	12
16	16
20	20
25	25
32	32
40	40
50	50

8 Tool Length (h)

h (mm)	h (mm)
D	60
E	70
F	80
H	100
K	125
M	150
N	160
P	170
R	200
S	250
T	300
U	350

9 Insert Size

Inscribed Circle	d	d	d	d	d	d	
d (mm)	R, S		T (60°)	C (80°)	E (75°)	D (55°)	V (35°)
5.56			09				
6.35	06		11				
7.94	07		13				
9.52	09		16	09		11	16
12.70	12		22	12	13	15	22
15.87	15		27	16		19	
19.05	19		33	19		23	
25.40	25		44	25		31	

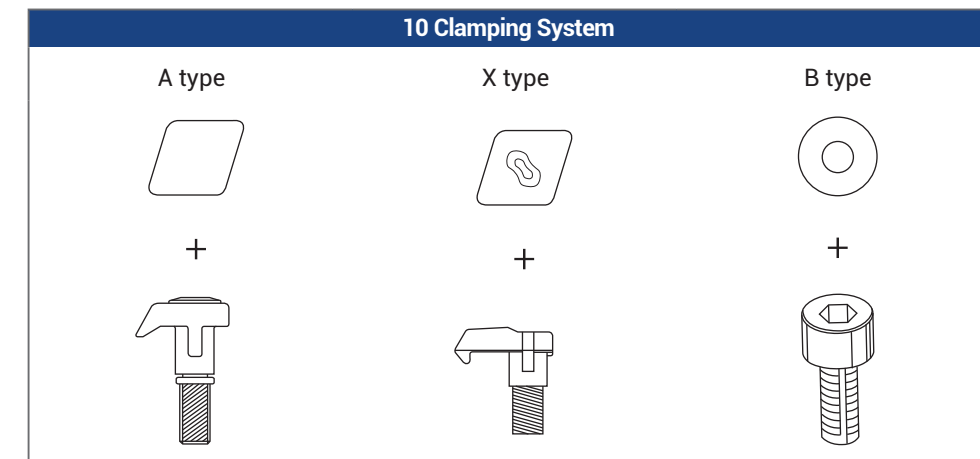

11 Insert Thickness

Index	s (mm)
3	3.18
4	4.76
6	6.35
7	7.94
9	9.52

EXTERNAL TOOLHOLDER

CCLN

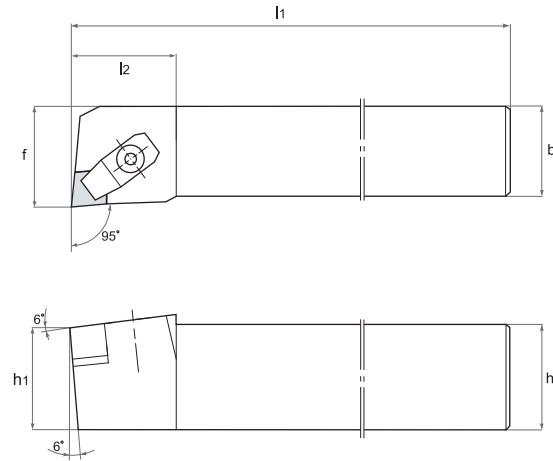
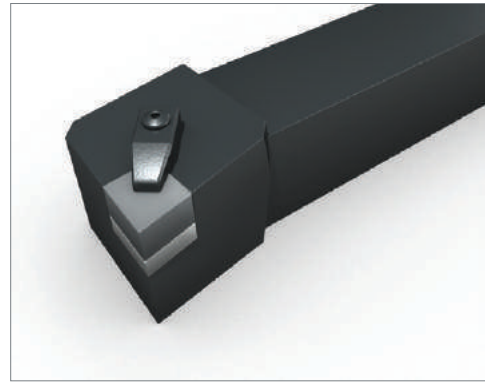

Type	Dimensions (mm)					Stock		Insert	Spare Parts			
	h(h ₁)	b	l ₁	l ₂	f	R	L		Clamp & Clamp Screw	Shim	Shim Screw	Wrench
CCLNR/L 2525M12-A4	25	25	150	27	32	●	●	CNGN1204	UH1	SHCN4A	BM510	LW4
CCLNR/L 2525M12-A7	25	25	150	27	32	●	●	CNGN1207	UH1	SHCN4A	BM510	LW4
CCLNR/L 2525M12-X7	25	25	150	27	32	●	●	CNG(V)X1207	UH5	SHCN4A	BM510	LW4
CCLNR/L 3225P12-A4	32	25	170	27	32	●	●	CNGN1204	UH1	SHCN4A	BM510	LW4
CCLNR/L 3225P12-A7	32	25	170	27	32	●	●	CNGN1207	UH1	SHCN4A	BM510	LW4
CCLNR/L 3225P12-X7	32	25	170	27	32	●	●	CNG(V)X1207	UH5	SHCN4A	BM510	LW4
CCLNR/L 3225P16-X7	32	25	170	27	32	●		CNG(V)X1607	UH5	SHCN5A	FM510S	LW4
CCLNR/L 3225P16-A7	32	25	170	27	32			CNGN1607	UH1	SHCN5A	FM510S	LW4
CCLNR/L 4040S19-A7	40	40	250	40	50			CNGN1907	UH4	SHCN6A	FM615S	LW5
CCLNR/L 5050T25-A9	50	50	300	43	60			CNGN2509	UH4	SHCN8A	FM815S	LW5

Spare parts												
Clamp & Clamp Screw			Shim				Shim Screw			Wrench		
UH1	UH4	UH5	SHCN4A	SHCN5A	SHCN6A	SHCN8	BM510	FM510	FM615	FM815	LW4	LW5

CNGN	CNGX	CNVX
Page 26	Page 28	Page 28

EXTERNAL TOOLHOLDER

CCBN

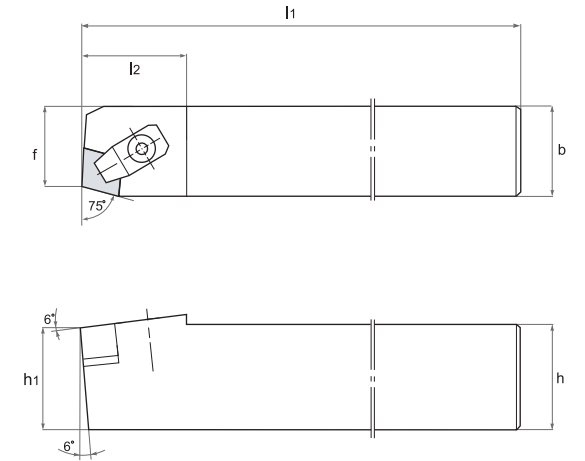
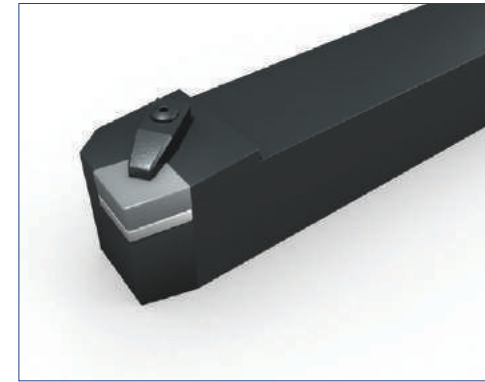

Type	Dimensions (mm)					Stock		Insert	Spare Parts			
	h(h ₁)	b	l ₁	l ₂	f	R	L		Clamp & Clamp Screw	Shim	Shim Screw	Wrench
CCBNR/L 2525M12-A4	25	25	150	27	22		●	CNGN1204	UH1	SHCN4A	BM510	LW4
CCBNR/L 2525M12-A7	25	25	150	27	22	●		CNGN1207	UH1	SHCN4A	BM510	LW4
CCBNR/L 2525M12-X7	25	25	150	27	22			CNG(V)X1207	UH5	SHCN4A	BM510	LW4
CCBNR/L 3225P12-A4	32	25	170	27	22			CNGN1204	UH1	SHCN4A	BM510	LW4
CCBNR/L 3225P12-A7	32	25	170	27	22			CNGN1207	UH1	SHCN4A	BM510	LW4
CCBNR/L 3225P12-X7	32	25	170	27	22			CNG(V)X1207	UH5	SHCN4A	BM510	LW4
CCBNR/L 3225P16-A7	32	25	170	27	27			CNGN1607	UH1	SHCN5A	FM510S	LW4
CCBNR/L 3225P16-X7	32	25	170	27	27			CNG(V)X1607	UH5	SHCN5A	FM510S	LW4
CCBNR/L 4040S19-A7	40	40	250	40	36			CNGN1907	UH4	SHCN6A	FM615S	LW5
CCBNR/L 5050T25-A9	50	50	300	43	45			CNGN2509	UH4	SHCN8A	FM815S	LW5

Spare parts												
Clamp & Clamp Screw			Shim				Shim Screw			Wrench		
UH1	UH4	UH5	SHCN4A	SHCN5A	SHCN6A	SHCN8	BM510	FM51	FM615	FM815S	LW4	LW5

CNGN	CNGX	CNVX
Page 26	Page 28	Page 28

EXTERNAL TOOLHOLDER

CCKN

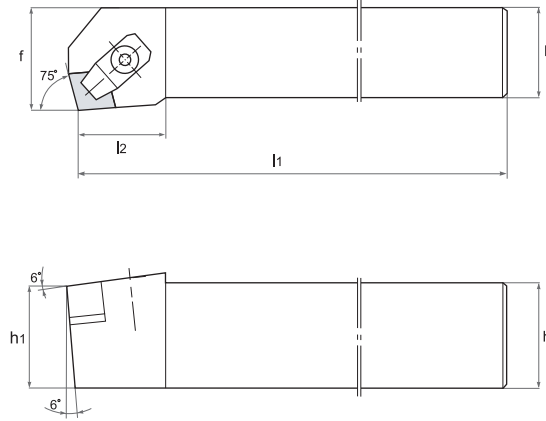
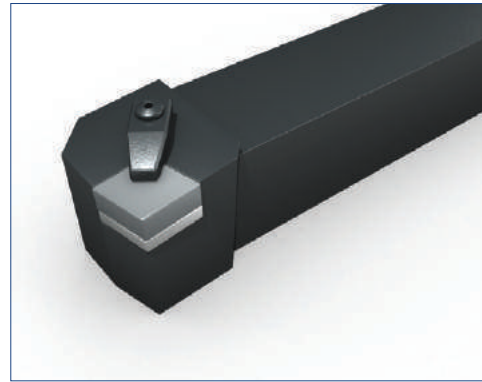

Type	Dimensions (mm)					Stock		Insert	Spare Parts			
	h(h ₁)	b	l ₁	l ₂	f	R	L		Clamp & Clamp Screw	Shim	Shim Screw	Wrench
CCKNR/L 2525M12-A4	25	25	150	24	32			CNGN1204	UH1	SHCN4A	BM510	LW4
CCKNR/L 2525M12-A7	25	25	150	24	32	●	●	CNGN1207	UH1	SHCN4A	BM510	LW4
CCKNR/L 2525M12-X7	25	25	150	24	32	●	●	CNG(V)X1207	UH5	SHCN4A	BM510	LW4
CCKNR/L 3225P12-A4	32	25	170	24	32			CNGN1204	UH1	SHCN4A	BM510	LW4
CCKNR/L 3225P12-A7	32	25	170	24	32		●	CNGN1207	UH1	SHCN4A	BM510	LW4
CCKNR/L 3225P12-X7	32	25	170	24	32	●	●	CNG(V)X1207	UH5	SHCN4A	BM510	LW4

Spare parts				
Clamp & Clamp Screw		Shim	Shim Screw	Wrench
UH1	UH5	SHCN4A	BM510	LW4

CNGN	CNGX	CNVX
Page 26	Page 28	Page 28

EXTERNAL TOOLHOLDER

CDHN

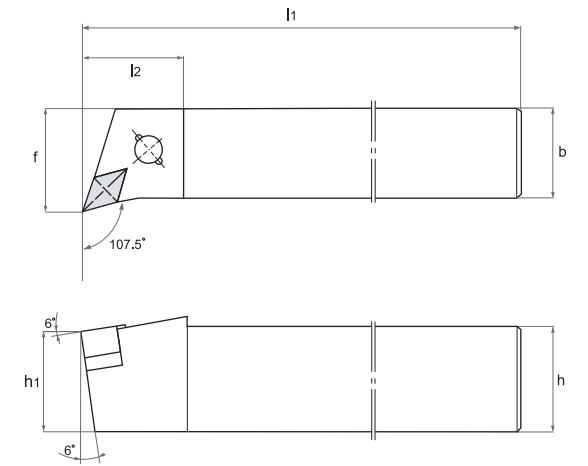
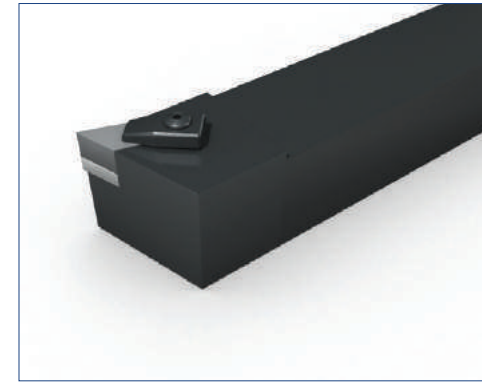

Type	Dimensions (mm)					Stock		Insert	Spare Parts			
	h(h ₁)	b	l ₁	l ₂	f	R	L		Clamp & Clamp Screw	Shim	Shim Screw	Wrench
CDHNR/L 2525M15-A4	25	25	150	33	32	●		DNGN1504	UH24S	SHDN4A	BM510	LW4
CDHNR/L 2525M15-A7	25	25	150	33	32	●	●	DNGN1507	UH24S	SHDN4A	BM510	LW4
CDHNR/L 2525M12-X7	25	25	150	30	32			DNGX1207	UH5	SHDN3A	TM3508	LW4
CDHNR/L 2525M15-X7	25	25	150	33	32			DNGX1507	UH24	SHDN4A	BM510	LW4
CDHNR/L 3225P15-A4	32	25	170	33	32			DNGN1504	UH24S	SHDN4A	BM510	LW4
CDHNR/L 3225P15-A7	32	25	170	33	32			DNGN1507	UH24S	SHDN4A	BM510	LW4
CDHNR/L 3225P12-X7	32	25	170	30	32			DNGX1207	UH5	SHDN3A	TM3508	LW4
CDHNR/L 3225P15-X7	32	25	170	33	32			DNGX1507	UH24	SHDN4A	BM510	LW4

Spare parts					
Clamp & Clamp Screw		Shim	Shim Screw	Wrench	
UH24S	UH5	SHDN3A	SHDN4A	TM3508	BM510

DNGN	DNGX
Page 33	Page 34

EXTERNAL TOOLHOLDER

CDJN

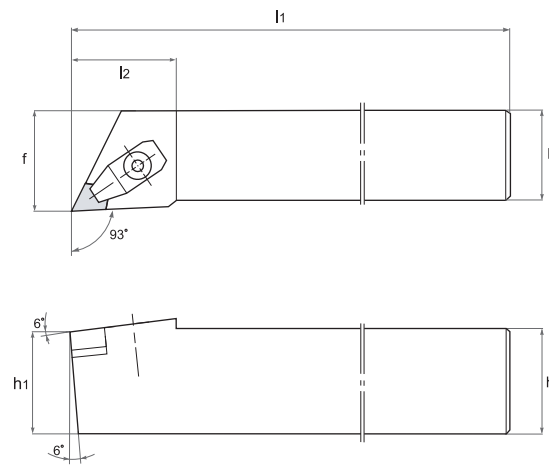
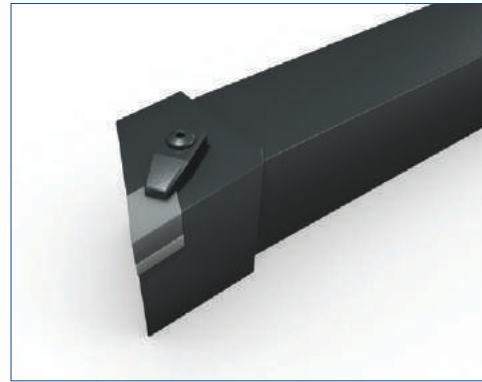

Type	Dimensions (mm)					Stock		Insert	Spare Parts			
	h(h ₁)	b	l ₁	l ₂	f	R	L		Clamp & Clamp Screw	Shim	Shim Screw	Wrench
CDJNR/L 2525M15-A4	25	25	150	38	32	●		DNGN1504	UH24S	SHDN4A	BM510	LW4
CDJNR/L 2525M15-A7	25	25	150	38	32	●	●	DNGN1507	UH24S	SHDN4A	BM510	LW4
CDJNR/L 2525M12-X7	25	25	150	38	32	●	●	DNGX1207	UH5	SHDN3A	TM3508	LW4
CDJNR/L 2525M15-X7	25	25	150	38	32		●	DNGX1507	UH5	SHDN4A	BM510	LW4
CDJNR/L 3225P15-A4	32	25	170	38	32			DNGN1504	UH24S	SHDN4A	BM510	LW4
CDJNR/L 3225P15-A7	32	25	170	38	32	●	●	DNGN1507	UH24S	SHDN4A	BM510	LW4
CDJNR/L 3225P12-X7	32	25	170	38	32		●	DNGX1207	UH5	SHDN3A	TM3507	LW4
CDJNR/L 3225P15-X7	32	25	170	38	32	●		DNGX1507	UH5	SHDN4A	BM510	LW4

Spare parts						
Clamp & Clamp Screw		Shim		Shim Screw		Wrench
UH24S	UH5	SHDN3A	SHDN4A	TM3507	BM510	LW4

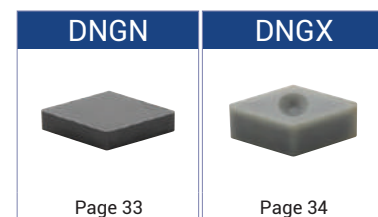

EXTERNAL TOOLHOLDER

CDNN

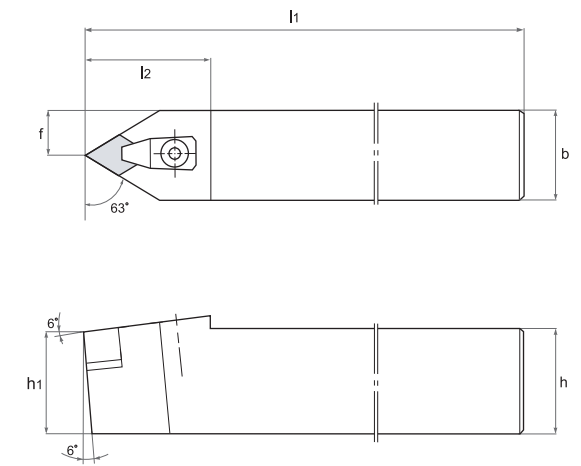
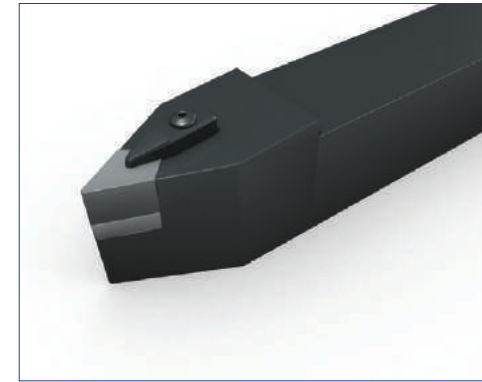

Type	Dimensions (mm)					Stock		Insert	Spare Parts			
	h(h ₁)	b	l ₁	l ₂	f	R	L		Clamp & Clamp Screw	Shim	Shim Screw	Wrench
CDNNN 2525M15-A4	25	25	150	40	12.5			DNGN1504	UH24S	SHDN4A	BM510	LW4
CDNNN 2525M15-A7	25	25	150	40	12.5			DNGN1507	UH24S	SHDN4A	BM510	LW4
CDNNN 4025M15-A7	40	25	150	40	12.5			DNGN1507	UH24S	SHDN4A	BM510	LW4

Spare parts			
Clamp & Clamp Screw	Shim	Shim Screw	Wrench
UH24S	SHDN4A	BM510	LW4



EXTERNAL TOOLHOLDER

CEFN

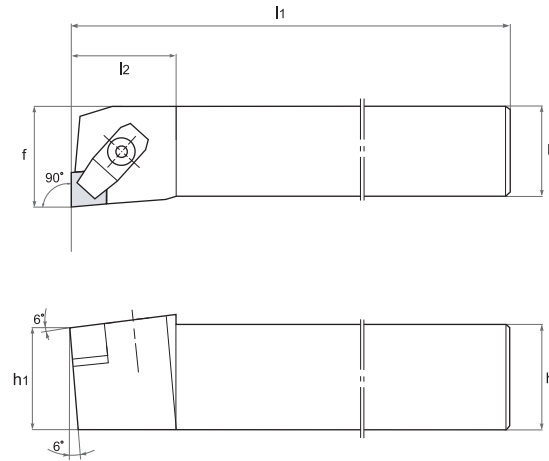
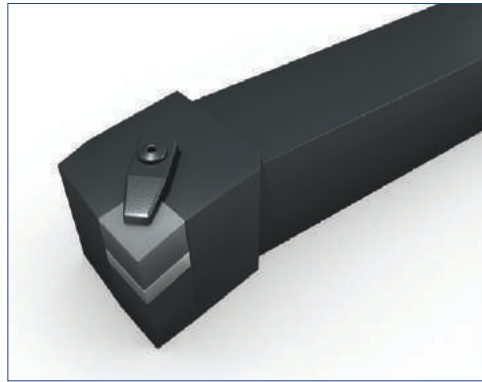

Type	Dimensions (mm)					Stock		Insert	Spare Parts			
	h(h ₁)	b	l ₁	l ₂	f	R	L		Clamp & Clamp Screw	Shim	Shim Screw	Wrench
CEFNR/L 2525M13-A7	25	25	150	27	32			ENGN1307	UH1	SHEN4A	BM510	LW4
CEFNR/L 3225P13-A7	32	25	170	27	32			ENGN1307	UH1	SHEN4A	BM510	LW4

Spare parts			
Clamp & Clamp Screw	Shim	Shim Screw	Wrench
UH1	SHEN4A	BM510	LW4

ENGN

Page 35

EXTERNAL TOOLHOLDER

CEGN

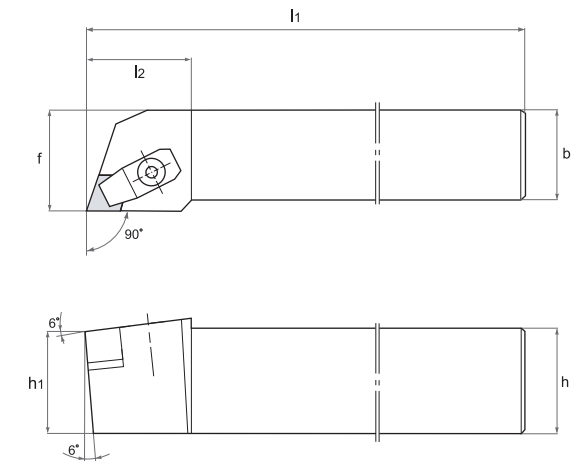
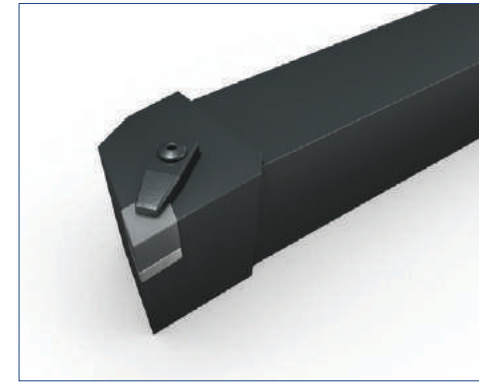

Type	Dimensions (mm)					Stock		Insert	Spare Parts			
	h(h ₁)	b	l ₁	l ₂	f	R	L		Clamp & Clamp Screw	Shim	Shim Screw	Wrench
CEGNR/L 2525M13-A7	25	25	150	27	32			ENGN1307	UH1	SHEN4A	BM510	LW4
CEGNR/L 3225P13-A7	32	25	170	27	32	●	●	ENGN1307	UH1	SHEN4A	BM510	LW4

Spare parts			
Clamp & Clamp Screw	Shim	Shim Screw	Wrench
UH1	SHEN4A	BM510	LW4

ENGN

Page 35

EXTERNAL TOOLHOLDER

CEJN

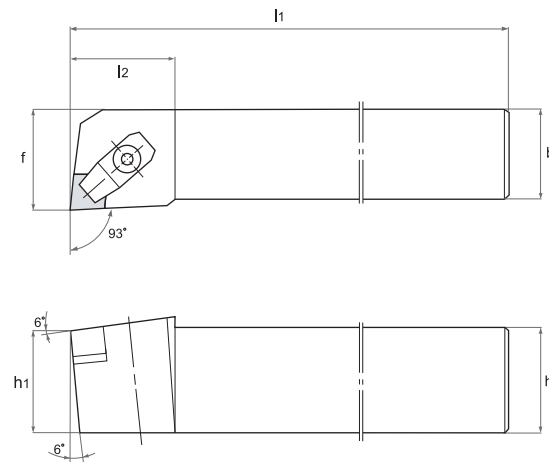
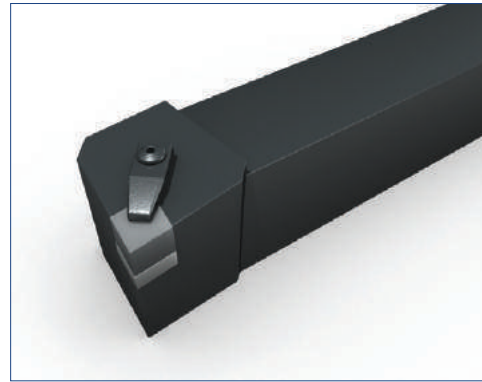

Type	Dimensions (mm)					Stock		Insert	Spare Parts			
	h(h ₁)	b	l ₁	l ₂	f	R	L		Clamp & Clamp Screw	Shim	Shim Screw	Wrench
CEJNR/L 2525M13-A7	25	25	150	27	32	●	●	ENGN1307	UH1	SHEN4A	BM510	LW4
CEJNR/L 3225P13-A7	32	25	170	27	32			ENGN1307	UH1	SHEN4A	BM510	LW4

Spare parts			
Clamp & Clamp Screw	Shim	Shim Screw	Wrench
UH1	SHEN4A	BM510	LW4

ENGN

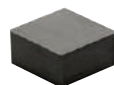

Page 35

EXTERNAL TOOLHOLDER

CRDN

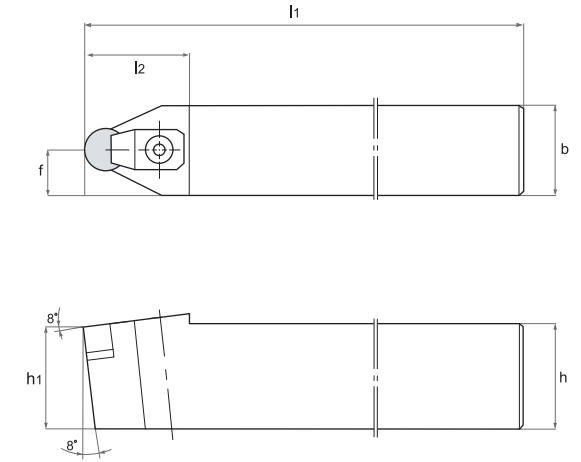
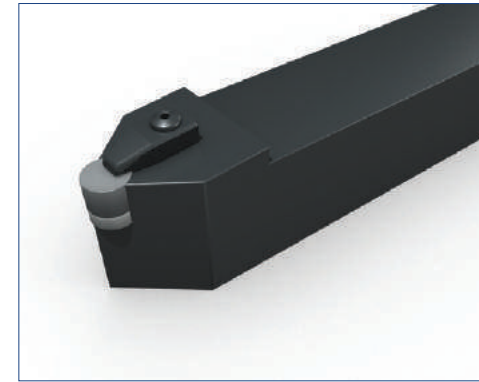

Type	Dimensions (mm)					Stock		Insert	Spare Parts			
	h(h ₁)	b	l ₁	l ₂	f	R	L		Clamp & Clamp Screw	Shim	Shim Screw	Wrench
CRDNN 2525M09-A4	25	25	150	32	12.5	●		RNGN0904	UH1	SHRN3A	TM3507	LW4
CRDNN 2525M09-A7	25	25	150	32	12.5	●		RNGN0907	UH1	SHRN3A	TM3507	LW4
CRDNN 2525M12-A4	25	25	150	32	12.5		●	RNGN1204	UH1	SHRN4A	BM510	LW4
CRDNN 2525M12-A7	25	25	150	32	12.5		●	RNGN1207	UH1	SHRN4A	BM510	LW4
CRDNN 2525M12-X7	25	25	150	32	12.5			RNGX1207	UH5	SHRN4A	BM510	LW4
CRDNN 3225P12-A4	32	25	170	32	12.5			RNGN1204	UH1	SHRN4A	BM510	LW4
CRDNN 3225P12-A7	32	25	170	32	12.5	●		RNGN1207	UH1	SHRN4A	BM510	LW4
CRDNN 3225P12-X7	32	25	170	32	12.5			RNGX1207	UH5	SHRN4A	BM510	LW4
CRDNN 3225P15-A7	32	25	170	32	12.5			RNGN1507	UH1	SHRN5A	BM510	LW4
CRDNN 3225P19-A7	32	25	170	32	12.5	●		RNGN1907	UH4	SHRN6A	FM510	LW5

Spare parts											
Clamp & Clamp Screw			Shim			Shim Screw			Wrench		
UH1	UH4	UH5	SHRN3A	SHRN4A	SHRN5A	SHRN6	BM510	TM3507	FM512	LW4	LW6

RNGN



Page 36

RNGX .. DP

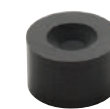

Page 38

EXTERNAL TOOLHOLDER

CRGN

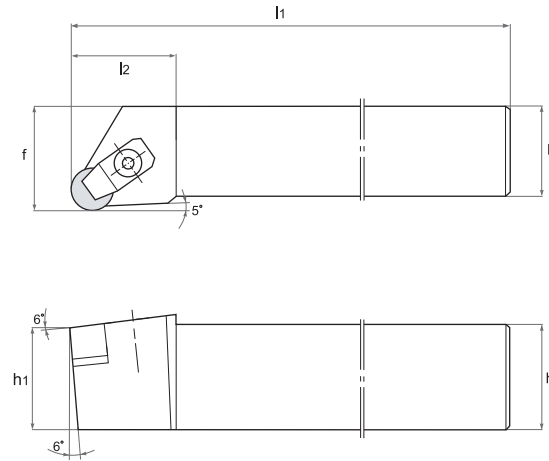
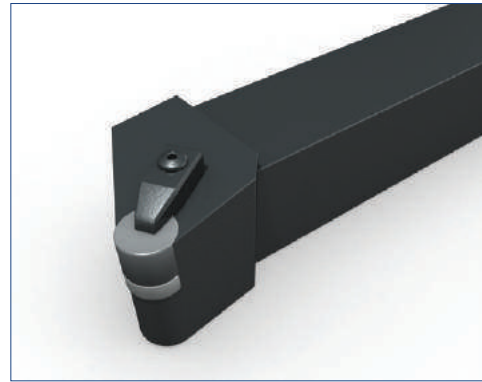

Type	Dimensions (mm)					Stock		Insert	Spare Parts			
	h(h ₁)	b	l ₁	l ₂	f	R	L		Clamp & Clamp Screw	Shim	Shim Screw	Wrench
CRGNR/L 2525M09-A4	25	25	150	32	32			RNGN0904	UH1	SHRN3A	TM3507	LW4
CRGNR/L 2525M09-A7	25	25	150	32	32	●		RNGN0907	UH1	SHRN3A	TM3507	LW4
CRGNR/L 2525M12-A4	25	25	150	35	32	●		RNGN1204	UH1	SHRN4A	BM510	LW4
CRGNR/L 2525M12-A7	25	25	150	35	32	●		RNGN1207	UH1	SHRN4A	BM510	LW4
CRGNR/L 2525M12-X7	25	25	150	35	32	●		RNGX1207	UH5	SHRN4A	BM510	LW4
CRGNR/L 3225P12-A4	32	25	170	35	32	●		RNGN1204	UH1	SHRN4A	BM510	LW4
CRGNR/L 3225P12-A7	32	25	170	35	32	●		RNGN1207	UH1	SHRN4A	BM510	LW4
CRGNR/L 3225P12-X7	32	25	170	35	32			RNGX1207	UH5	SHRN4A	BM510	LW4
CRGNR/L 3225P15-A7	32	25	170	37	32	●		RNGN1507	UH1	SHRN5A	BM510	LW4
CRGNR/L 3225P19-A7	32	25	170	45	32	●		RNGN1907	UH4	SHRN6A	FM510	LW5

Spare parts											
Clamp & Clamp Screw			Shim			Shim Screw			Wrench		
UH1	UH4	UH5	SHRN3A	SHRN4A	SHRN5A	SHRN6A	BM510	TM3507	FM510	LW4	LW6

RNGN	RNGX .. DP
Page 36	Page 38

EXTERNAL TOOLHOLDER

CRDB

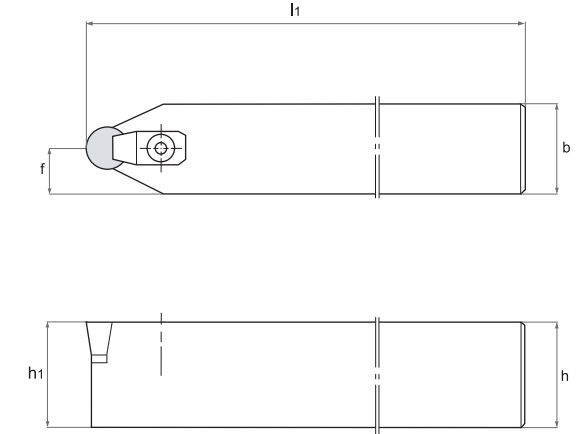
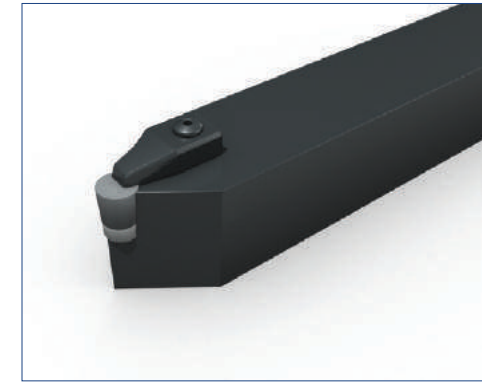

Type	Dimensions (mm)				Stock		Insert	Spare Parts			
	h(h ₁)	b	l ₁	f	R	L		Clamp & Clamp Screw	Shim	Shim Screw	Wrench
CRDBN 2525M12-A	25	25	150	12.5	●		RBGX12T	UH1	SHRB12	SH3015	LW4
CRDBN 2525M16-A	25	25	150	12.5	●		RBGX16T	UH1	SHRB16	SH3515	LW4
CRDBN 3225P12-A	32	32	170	16	●		RBGX12T	UH1	SHRB12	SH3015	LW4
CRDBN 3225P16-A	32	32	170	16	●		RBGX16T	UH1	SHRB16	SH3515	LW4
CRDBN 3225P20-A	32	32	170	16			RBGX20T	UH4	SHRB20	SH5015	LW5
CRDBN 3225P26-A	32	32	170	16			RBGX26T	UH4	SHRB26	SH6015	LW5

Spare parts											
Clamp & Clamp Screw		Shim				Shim Screw				Wrench	
UH1	UH4	SHRB12	SHRB16	SHRB20	SHRB26	SH3015	SH3515	SH5015	SH6015	LW4	LW6

RBGX
Page 56

EXTERNAL TOOLHOLDER

CRDC

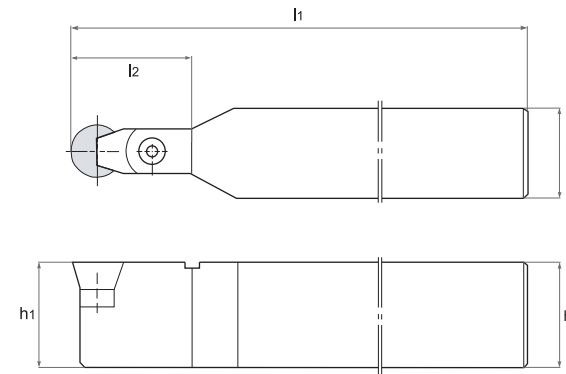
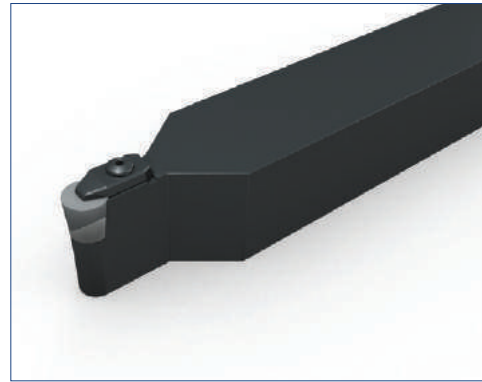

Type	Dimensions (mm)				Stock		Insert	Spare Parts			
	h(h ₁)	b	l ₁	l ₂	R	L		Clamp & Clamp Screw	Shim	Shim Screw	Wrench
CRDCN 3225P06-A4	32	25	170	20	●		RCGX0604	CLRC6	SHRC102	-	LW3
CRDCN 3225P06-A6	32	25	170	20	●		RCGX0606	CLRC6	SHRC102	-	LW3
CRDCN 3225P06-A7	32	25	170	20	●		RCGX0607	CLRC6	SHRC102	-	LW3
CRDCN 3225P09-A7	32	25	170	20	●		RCGX0907	UH1	SHRC103	FM315S	LW4
CRDCN 3225P12-A7	32	25	170	20	●		RCGX1207	UH1	SHRC104	FM315	LW4
CRDCN 5040T12-A7	50	40	300	30	●		RCGX1207	UH1	SHRC104	FM315	LW4
CRDCN 5040T15-A10	50	40	300	35	●		RCGX1510	UH1	SHRC105	FM415	LW4
CRDCN 5040T19-A10	50	40	300	45			RCGX1910	UH4	SHRC106	FM415	LW6
CRDCN 5040T25-A12	50	40	300	50			RCGX2512	UH4	SHRC108	FM515	LW6

Spare parts										
Clamp & Clamp Screw			Shim			Shim Screw		Wrench		
CLRC6	UH1	UH4	SHRC102	SHRC103	SHRC104	FM210	FM315	LW3	LW4	LW6
			SHRC105	SHRC106	SHRC108	FM415	FM515			



EXTERNAL TOOLHOLDER

CSBN

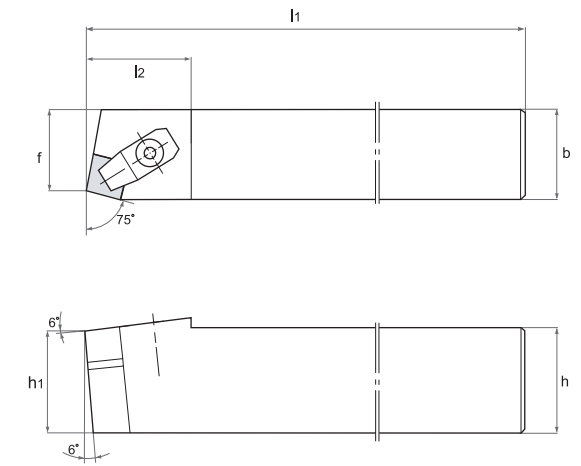
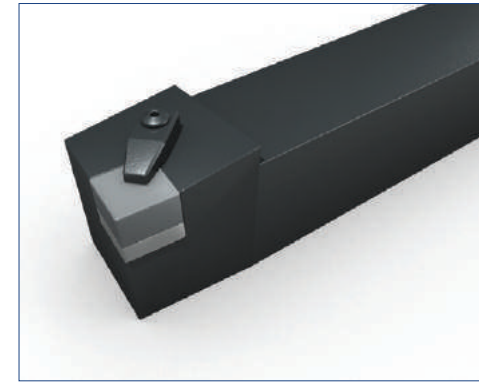

Type	Dimensions (mm)					Stock		Insert	Spare Parts			
	h(h ₁)	b	l ₁	l ₂	f	R	L		Clamp & Clamp Screw	Shim	Shim Screw	Wrench
CSBNR/L 2525M12-A4	25	25	150	27	22	●	●	SNGN1204	UH1	SHSN4A	BM510	LW4
CSBNR/L 2525M12-A7	25	25	150	27	22	●	●	SNGN1207	UH1	SHSN4A	BM510	LW4
CSBNR/L 2525M12-X7	25	25	150	27	22	●		SNGX1207	UH5	SHSN4A	BM510	LW4
CSBNR/L 2525M15-A7	25	25	150	34	22			SNGN1507	UH1	SHSN5A	FM512S	LW4
CSBNR/L 2525M15-X7	25	25	150	34	22			SNGX1507	UH5	SHSN5A	FM512S	LW4
CSBNR/L 3225P12-A7	32	25	170	27	22	●	●	SNGN1207	UH1	SHSN4A	BM510	LW4
CSBNR/L 3225P12-X7	32	25	170	27	22	●		SNGX1207	UH5	SHSN4A	BM510	LW4
CSBNR/L 3225P15-A7	32	25	170	34	22	●		SNGN1507	UH1	SHSN5A	FM512S	LW4
CSBNR/L 3225P15-X7	32	25	170	34	22			SNGX1507	UH5	SHSN5A	FM512S	LW4
CSBNR/L 4040S19-A7	40	40	250	45	35			SNGN1907	UH4	SHSN6A	FM615S	LW6
CSBNR/L 5050T25-A9	50	50	300	50	45			SNGN2509	UH4	SHSN8	FM815S	LW6

Spare parts										
Clamp & Clamp Screw			Shim		Shim Screw		Wrench			
UH1	UH4	UH5	SHSN4A	SHSN5A	BM510	FM512S	FM615S	LW4	LW6	
			SHSN6A	SHSN8A	FM815S					



EXTERNAL TOOLHOLDER

CSDN

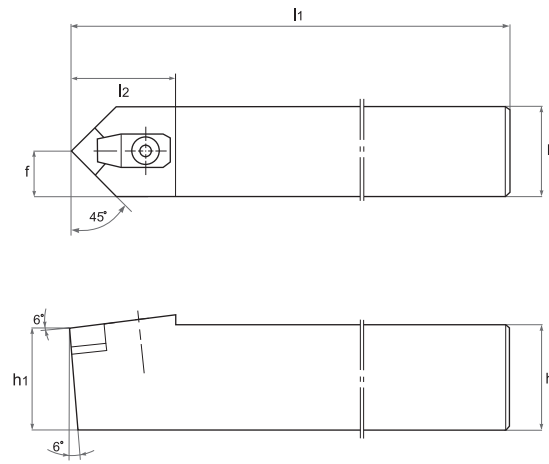
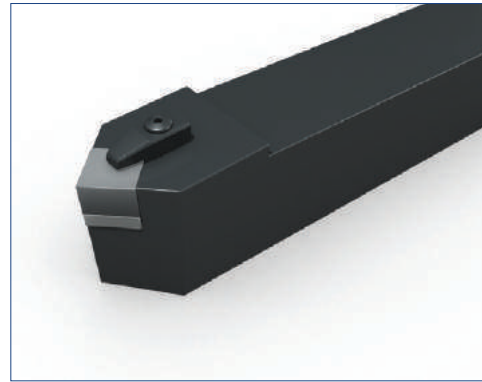

Type	Dimensions (mm)					Stock		Insert	Spare Parts			
	h(h ₁)	b	l ₁	l ₂	f	R	L		Clamp & Clamp Screw	Shim	Shim Screw	Wrench
CSDNN 2525M12-A4	25	25	150	35	12.5	●		SNGN1204	UH1	SHSN4A	BM510	LW4
CSDNN 2525M12-A7	25	25	150	35	12.5	●		SNGN1207	UH1	SHSN4A	BM510	LW4
CSDNN 2525M12-X7	25	25	150	35	12.5			SNGX1207	UH5	SHSN4A	BM510	LW4
CSDNN 2525M15-A7	25	25	150	38	12.5			SNGN1507	UH1	SHSN5A	FM512	LW4
CSDNN 2525M15-X7	25	25	150	38	12.5			SNGX1507	UH5	SHSN5A	FM512	LW4
CSDNN 3225P12-A7	32	25	170	35	12.5	●		SNGN1207	UH1	SHSN4A	BM510	LW4
CSDNN 3225P12-X7	32	25	170	35	12.5			SNGX1207	UH5	SHSN4A	BM510	LW4
CSDNN 3225P15-A7	32	25	170	38	12.5	●		SNGN1507	UH1	SHSN5A	FM512	LW4
CSDNN 3225P15-X7	32	25	170	38	12.5			SNGX1507	UH5	SHSN5A	FM512	LW4
CSDNN 4040S19-A7	40	40	250	50	20	●		SNGN1907	UH4	SHSN6A	FM612	LW6
CSDNN 5050T25-A9	50	50	300	55	25	●		SNGN2509	UH4	SHSN8	FM815	LW6

Spare parts									
Clamp & Clamp Screw			Shim		Shim Screw			Wrench	
UH1	UH4	UH5	SHSN4A SHSN6A	SHSN5A SHSN8	BM510	FM512S FM815S	FM615S	LW4	LW6



EXTERNAL TOOLHOLDER

CSKN

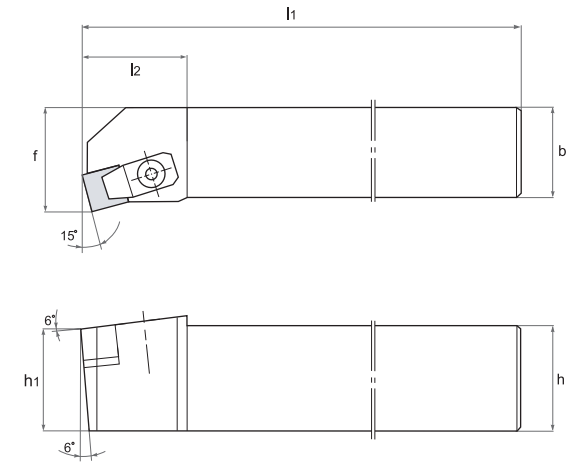
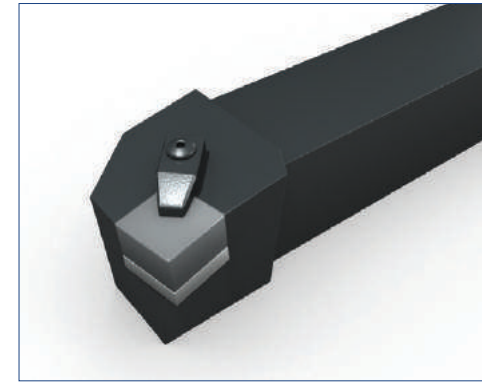

Type	Dimensions (mm)					Stock		Insert	Spare Parts			
	h(h ₁)	b	l ₁	l ₂	f	R	L		Clamp & Clamp Screw	Shim	Shim Screw	Wrench
CSKNR/L 2525M12-A4	25	25	150	34	32			SNGN1204	UH1	SHSN4A	BM510	LW4
CSKNR/L 2525M12-A7	25	25	150	34	32	●	●	SNGN1207	UH1	SHSN4A	BM510	LW4
CSKNR/L 2525M12-X7	25	25	150	34	32	●	●	SNGX1207	UH5	SHSN4A	BM510	LW4
CSKNR/L 2525M15-A7	25	25	150	40	32			SNGN1507	UH1	SHSN5A	FM512S	LW4
CSKNR/L 2525M15-X7	25	25	150	40	32			SNGX1507	UH5	SHSN5A	FM512S	LW4
CSKNR/L 3225P12-A7	32	25	170	34	32			SNGN1207	UH1	SHSN4A	BM510	LW4
CSKNR/L 3225P12-X7	32	25	170	34	32		●	SNGX1207	UH5	SHSN4A	BM510	LW4
CSKNR/L 3225P15-A7	32	25	170	40	32	●	●	SNGN1507	UH1	SHSN5A	FM512S	LW4
CSKNR/L 3225P15-X7	32	25	170	40	32			SNGX1507	UH5	SHSN5A	FM512S	LW4

Spare parts						
Clamp & Clamp Screw		Shim		Shim Screw		Wrench
UH1	UH5	SHSN4A	SHSN5A	BM510	FM512S	LW4



EXTERNAL TOOLHOLDER

CSRNR

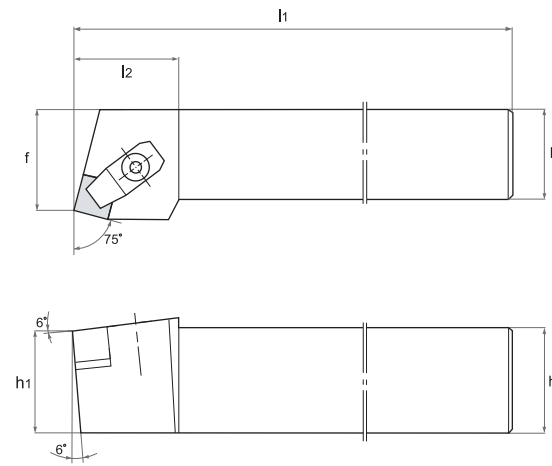
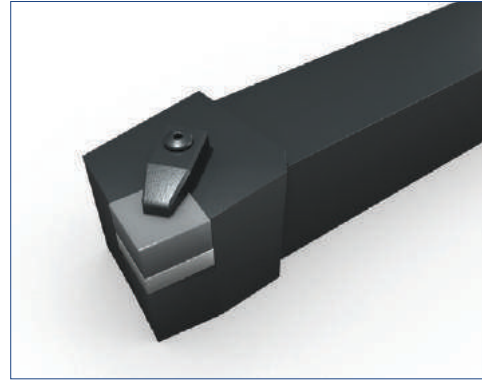

Type	Dimensions (mm)					Stock		Insert	Spare Parts			
	h(h ₁)	b	l ₁	l ₂	f	R	L		Clamp & Clamp Screw	Shim	Shim Screw	Wrench
CSRNR/L 2525M12-A4	25	25	150	32	27	●	●	SNGN1204	UH1	SHSN4A	BM510	LW4
CSRNR/L 2525M12-A7	25	25	150	32	27	●	●	SNGN1207	UH1	SHSN4A	BM510	LW4
CSRNR/L 2525M12-X7	25	25	150	32	27	●		SNGX1207	UH5	SHSN4A	BM510	LW4
CSRNR/L 2525M15-A7	25	25	150	34	27			SNGN1507	UH1	SHSN5A	FM512	LW4
CSRNR/L 2525M15-X7	25	25	150	34	27			SNGX1507	UH5	SHSN5A	FM512	LW4
CSRNR/L 3225P12-A7	32	25	170	32	27			SNGN1207	UH1	SHSN4A	BM510	LW4
CSRNR/L 3225P12-X7	32	25	170	32	27			SNGX1207	UH5	SHSN4A	BM510	LW4
CSRNR/L 3225P15-A7	32	25	170	34	27	●	●	SNGN1507	UH1	SHSN5A	FM512	LW4
CSRNR/L 3225P15-X7	32	25	170	34	27	●		SNGX1507	UH5	SHSN5A	FM512	LW4
CSRNR/L 4040S19-A7	40	40	250	47	43			SNGN1907	UH4	SHSN6A	FM612	LW6
CSRNR/L 5050T25-A9	50	50	300	54	53			SNGN2509	UH4	SHSN8	FM815	LW6

Spare parts									
Clamp & Clamp Screw			Shim		Shim Screw		Wrench		
UH1	UH4	UH5	SHSN4A SHSN6A	SHSN5A SHSN8	BM510	FM512 FM815	FM612	LW4	LW6

SNGN	SNGX
Page 41	Page 42

EXTERNAL TOOLHOLDER

CSSNR

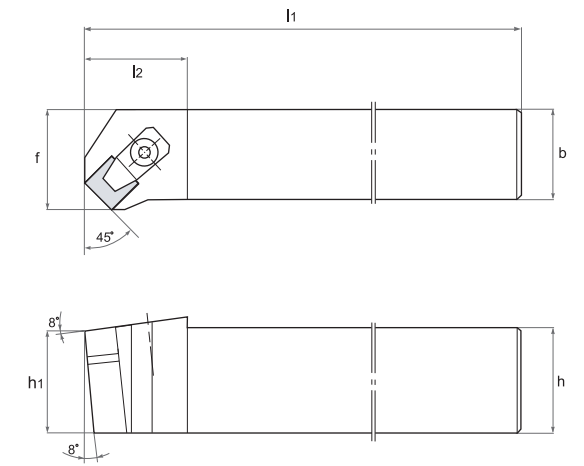
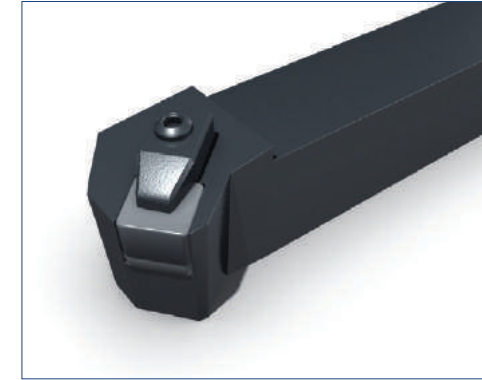

Type	Dimensions (mm)					Stock		Insert	Spare Parts			
	h(h ₁)	b	l ₁	l ₂	f	R	L		Clamp & Clamp Screw	Shim	Shim Screw	Wrench
CSSNR/L 2525M12-A4	25	25	150	35	32			SNGN1204	UH1	SHSN4A	BM510	LW4
CSSNR/L 2525M12-A7	25	25	150	35	32	●	●	SNGN1207	UH1	SHSN4A	BM510	LW4
CSSNR/L 2525M12-X7	25	25	150	35	32		●	SNGX1207	UH5	SHSN4A	BM510	LW4
CSSNR/L 2525M15-A7	25	25	150	37	32	●		SNGN1507	UH1	SHSN5A	FM512S	LW4
CSSNR/L 2525M15-X7	25	25	150	37	32			SNGX1507	UH5	SHSN5A	FM512S	LW4
CSSNR/L 3225P12-A7	32	25	170	35	32	●		SNGN1207	UH1	SHSN4A	BM510	LW4
CSSNR/L 3225P12-X7	32	25	170	35	32			SNGX1207	UH5	SHSN4A	BM510	LW4
CSSNR/L 3225P15-A7	32	25	170	37	32			SNGN1507	UH1	SHSN5A	FM512S	LW4
CSSNR/L 3225P15-X7	32	25	170	37	32			SNGX1507	UH5	SHSN5A	FM512S	LW4

Spare parts						
Clamp & Clamp Screw		Shim		Shim Screw		Wrench
UH1	UH5	SHSN4A	SHSN5A	BM510	FM512S	LW4

SNGN	SNGX
Page 41	Page 42

EXTERNAL TOOLHOLDER

CSYN

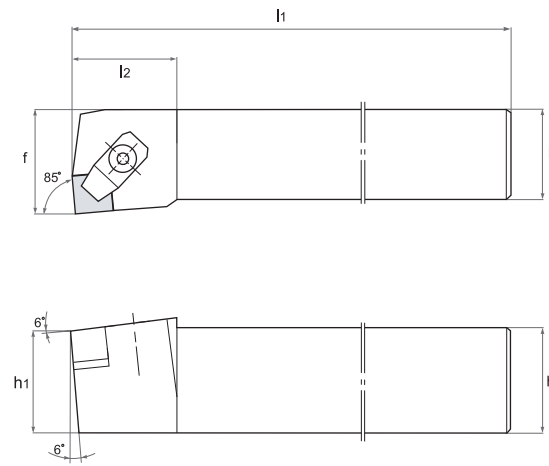
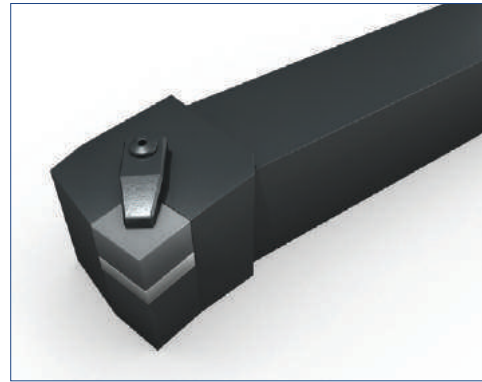

Type	Dimensions (mm)					Stock		Insert	Spare Parts			
	h(h ₁)	b	l ₁	l ₂	f	R	L		Clamp & Clamp Screw	Shim	Shim Screw	Wrench
CSYNR/L 2525M12-A4	25	25	150	27	32	●		SNGN1204	UH1	SHSN4A	BM510	LW4
CSYNR/L 2525M12-A7	25	25	150	27	32	●		SNGN1207	UH1	SHSN4A	BM510	LW4
CSYNR/L 2525M12-X7	25	25	150	27	32			SNGX1207	UH5	SHSN4A	BM510	LW4
CSYNR/L 2525M15-A7	25	25	150	27	32			SNGN1507	UH1	SHSN5A	FM512S	LW4
CSYNR/L 2525M15-X7	25	25	150	27	32			SNGX1507	UH5	SHSN5A	FM512S	LW4
CSYNR/L 3225P12-A7	32	25	170	27	32			SNGN1207	UH1	SHSN4A	BM510	LW4
CSYNR/L 3225P12-X7	32	25	170	27	32			SNGX1207	UH5	SHSN4A	BM510	LW4
CSYNR/L 3225P15-A7	32	25	170	27	32			SNGN1507	UH1	SHSN5A	FM512S	LW4
CSYNR/L 3225P15-X7	32	25	170	27	32			SNGX1507	UH5	SHSN5A	FM512S	LW4

Spare parts						
Clamp & Clamp Screw		Shim		Shim Screw		Wrench
UH1	UH5	SHSN4A	SHSN5A	BM510	FM512	LW4



EXTERNAL TOOLHOLDER

CTFN

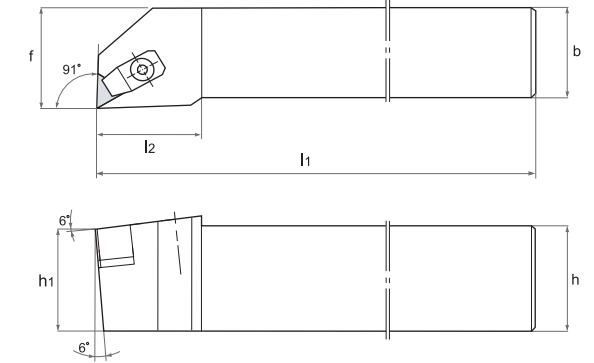
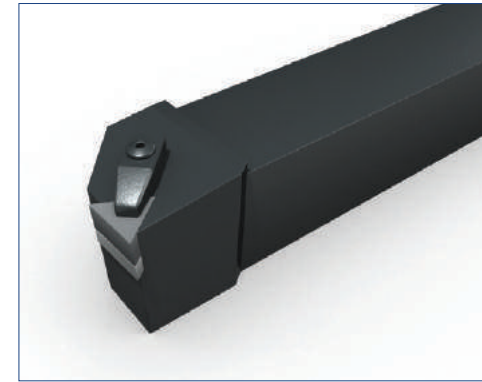

Type	Dimensions (mm)					Stock		Insert	Spare Parts			
	h(h ₁)	b	l ₁	l ₂	f	R	L		Clamp & Clamp Screw	Shim	Shim Screw	Wrench
CTFNR/L 2525M16-A4	25	25	150	29	32			TNGN1604	UH1	SHTN3A	BM408	LW4
CTFNR/L 2525M16-A7	25	25	150	29	32			TNGN1607	UH1	SHTN3A	BM408	LW4
CTFNR/L 2525M22-A4	25	25	150	32	32			TNGN2204	UH1	SHTN4A	FM410	LW4
CTFNR/L 2525M22-A7	25	25	150	32	32	●		TNGN2207	UH1	SHTN4A	FM410	LW4
CTFNR/L 3225P16-A4	32	25	170	29	32			TNGN1604	UH1	SHTN3A	BM408	LW4
CTFNR/L 3225P16-A7	32	25	170	29	32			TNGN1607	UH1	SHTN3A	BM408	LW4
CTFNR/L 3225P22-A4	32	25	170	32	32			TNGN2204	UH1	SHTN4A	FM410	LW4
CTFNR/L 3225P22-A7	32	25	170	32	32			TNGN2207	UH1	SHTN4A	FM410	LW4

Spare parts					
Clamp & Clamp Screw	Shim		Shim Screw		Wrench
UH1	SHTN3A	SHTN4A	BM408	FM410	LW4



EXTERNAL TOOLHOLDER

CTGN

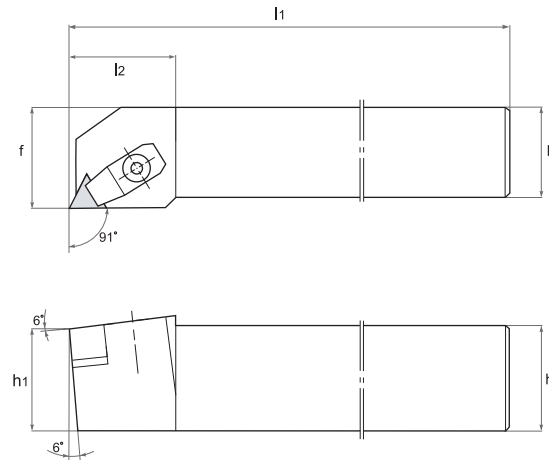
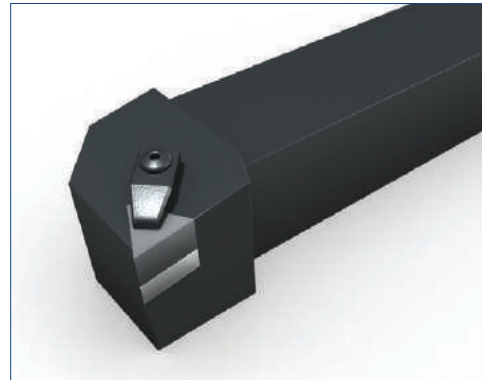

Type	Dimensions (mm)					Stock		Insert	Spare Parts			
	h(h ₁)	b	l ₁	l ₂	f	R	L		Clamp & Clamp Screw	Shim	Shim Screw	Wrench
CTGNR/L 2525M16-A4	25	25	150	26	32	●	●	TNGN1604	UH1	SHTN3A	BM408	LW4
CTGNR/L 2525M16-A7	25	25	150	26	32		●	TNGN1607	UH1	SHTN3A	BM408	LW4
CTGNR/L 2525M22-A4	25	25	150	32	32	●		TNGN2204	UH1	SHTN4A	FM410	LW4
CTGNR/L 2525M22-A7	25	25	150	32	32			TNGN2207	UH1	SHTN4A	FM410	LW4
CTGNR/L 3225P16-A4	32	25	170	26	32	●	●	TNGN1604	UH1	SHTN3A	BM408	LW4
CTGNR/L 3225P16-A7	32	25	170	26	32			TNGN1607	UH1	SHTN3A	BM408	LW4
CTGNR/L 3225P22-A4	32	25	170	32	32			TNGN2204	UH1	SHTN4A	FM410	LW4
CTGNR/L 3225P22-A7	32	25	170	32	32			TNGN2207	UH1	SHTN4A	FM410	LW4

Spare parts					
Clamp & Clamp Screw	Shim		Shim Screw		Wrench
UH1	SHTN3A	SHTN4A	BM408	FM410	LW4



EXTERNAL TOOLHOLDER

CWLN

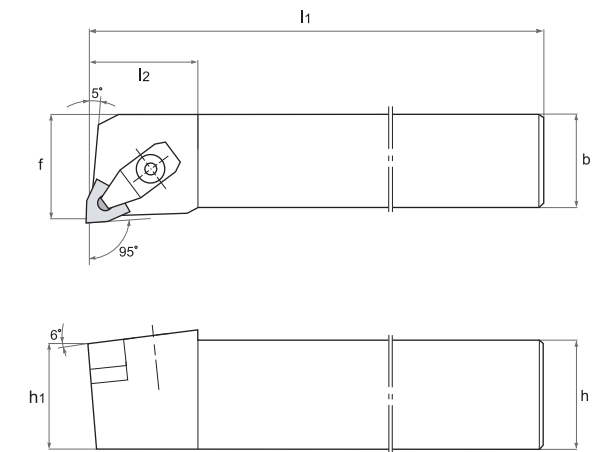
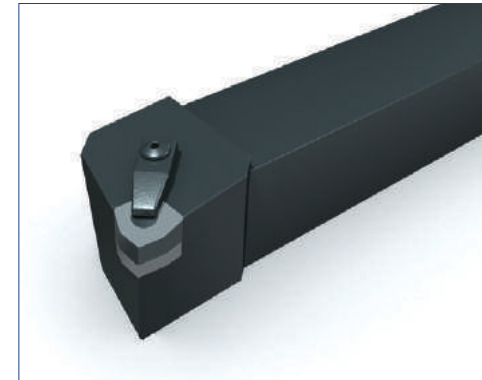

Type	Dimensions (mm)					Stock		Insert	Spare Parts			
	h(h ₁)	b	l ₁	l ₂	f	R	L		Clamp & Clamp Screw	Shim	Shim Screw	Wrench
CWLNLR/L 2525M08-X7	25	25	150	28	32	●	●	WNGX0807	UH5	SHWN4A	TM4010	LW4
CWLNLR/L 3225M08-X7	32	25	150	28	32	●	●	WNGX0807	UH5	SHWN4A	TM4010	LW4

Spare parts			
Clamp & Clamp Screw	Shim	Shim Screw	Wrench
UH5	SHWN4A	TM4010	LW4



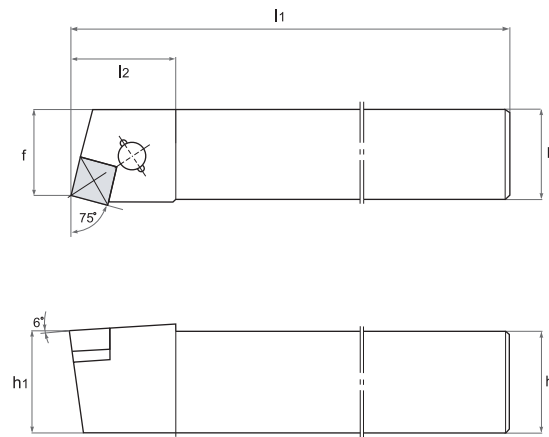
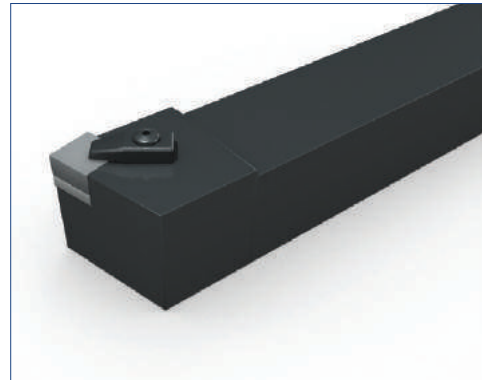

EXTERNAL TOOLHOLDER

CSRC

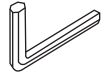

Type	Dimensions (mm)					Stock		Insert	Spare Parts			
	h(h ₁)	b	l ₁	l ₂	f	R	L		Clamp & Clamp Screw	Shim	Shim Screw	Wrench
CSRCR/L 2525M12-A4	25	25	150	32	27	●		SCGN1204	UH1	SHSC4A	SP3	LW4
CSRCR/L 3225P12-A4	32	25	170	32	27			SCGN1204	UH1	SHSC4A	SP3	LW4

Spare parts			
Clamp & Clamp Screw	Shim	Shim Screw	Wrench
			
UH1	SHSC4A	SP3	LW4

SCGN





Page 43

EXTERNAL TOOLHOLDER

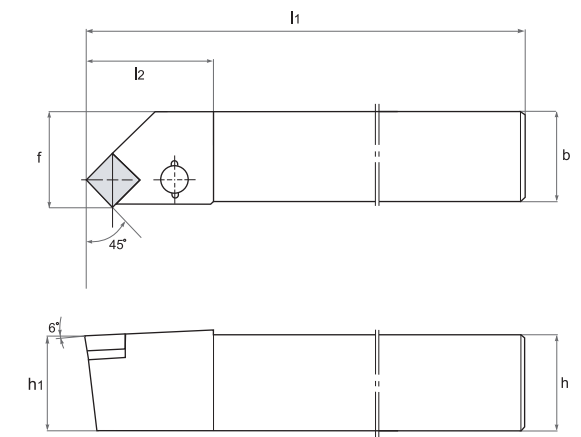
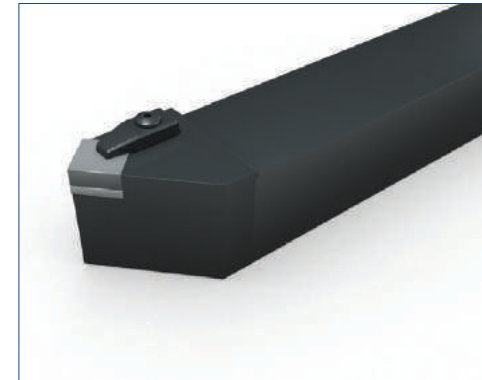
CSSC

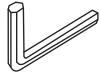

Type	Dimensions (mm)					Stock		Insert	Spare Parts			
	h(h ₁)	b	l ₁	l ₂	f	R	L		Clamp & Clamp Screw	Shim	Shim Screw	Wrench
CSSCR/L 2525M12-A4	25	25	150	35	32	●		SCGN1204	UH1	SHSC4A	SP3	LW4
CSSCR/L 3225P12-A4	32	25	170	35	32			SCGN1204	UH1	SHSC4A	SP3	LW4

Spare parts			
Clamp & Clamp Screw	Shim	Shim Screw	Wrench
			
UH1	SHSC4A	SP3	LW4

SCGN





Page 43

EXTERNAL TOOLHOLDER

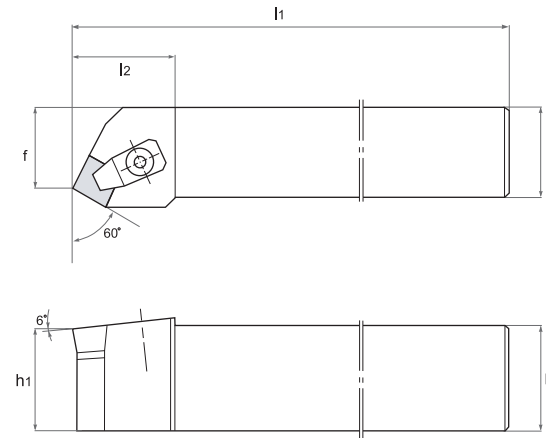
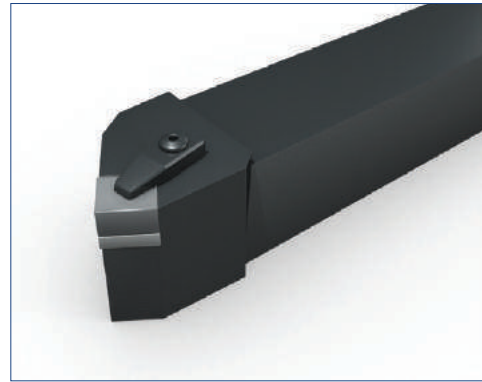
CSTP

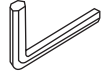

Type	Dimensions (mm)					Stock		Insert	Spare Parts			
	h(h ₁)	b	l ₁	l ₂	f	R	L		Clamp & Clamp Screw	Shim	Shim Screw	Wrench
CSTPR/L 2020K09-A3	20	20	125	24	17			SPGN0903	UH1	SHSC3A	SP3	LW4
CSTPR/L 2020K12-A3	20	20	125	30	17			SPGN1203	UH1	SHSC4A	SP3	LW4
CSTPR/L 2020K12-A4	20	20	125	30	17			SPGN1204	UH1	SHSC4A	SP3	LW4
CSTPR/L 2525M12-A3	25	25	150	30	22			SPGN1203	UH1	SHSC4A	SP3	LW4
CSTPR/L 2525M12-A4	25	25	150	30	22			SPGN1204	UH1	SHSC4A	SP3	LW4

Spare parts			
Clamp & Clamp Screw	Shim	Shim Screw	Wrench
			
UH1	SHSC3A SHSC4A	SP3	LW4

SPGN

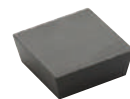



Page 44

EXTERNAL TOOLHOLDER

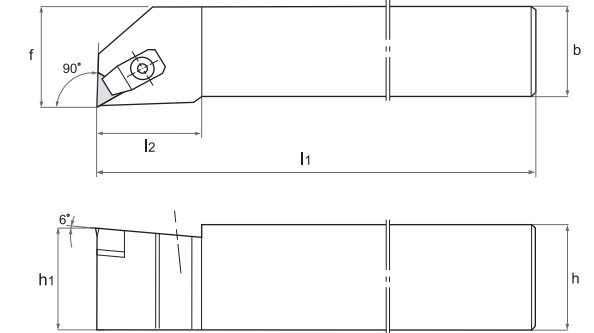
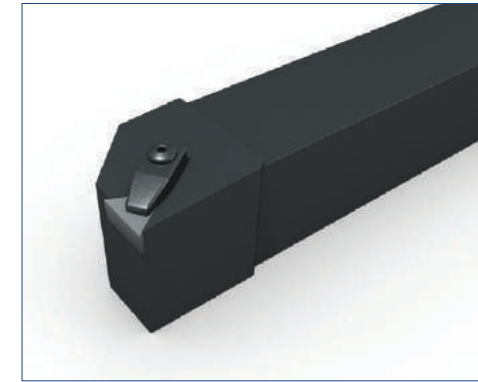
CTFP

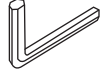

Type	Dimensions (mm)					Stock		Insert	Spare Parts			
	h(h ₁)	b	l ₁	l ₂	f	R	L		Clamp & Clamp Screw	Shim	Shim Screw	Wrench
CTFPR/L 2020K16-A3	20	20	125	20	25			TPGN1603	UH1	SHTC3A	SP3	LW4
CTFPR/L 2525M16-A3	25	25	150	20	32			TPGN1603	UH1	SHTC3A	SP3	LW4

Spare parts			
Clamp & Clamp Screw	Shim	Shim Screw	Wrench
			
UH1	SHTC3A	SP3	LW3 LW4

TPGN

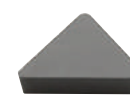

Page 48

EXTERNAL TOOLHOLDER

HRCD

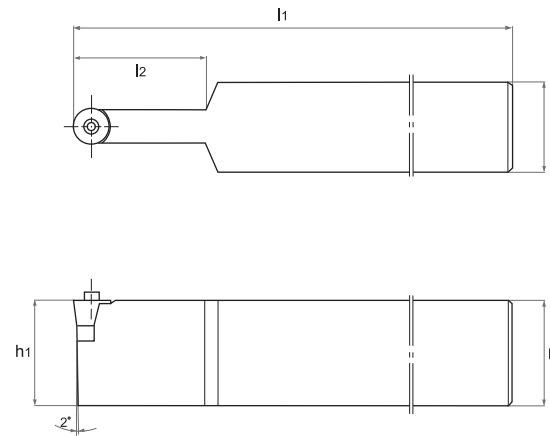
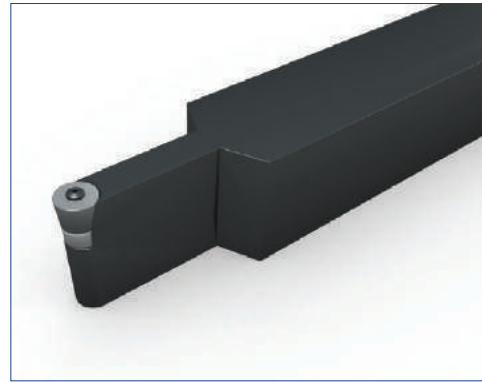

Type	Dimensions (mm)				Stock		Insert	Spare Parts			
	h(h ₁)	b	l ₁	f	R	L		Clamp & Clamp Screw	Shim	Shim Screw	Wrench
HRCD 2525M12-B6	25	25	150	15	●		CDH1206	HB 2	SHCD22		LW2.5
HRCD 2525M19-B9	25	25	150	15	●		CDH1909	HB 3	SHCD33		LW5
HRCD 3225R19-B9	32	25	200	38	●		CDH1909	HB 3	SHCD33		LW5
HRCD 4035S19-B9	40	35	250	45	●		CDH1909	HB 3	SHCD33		LW5
HRCD 4035S32-B19	40	35	250	45			CDH3219	HB 5	SHCD53		LW6
HRCD 5050T32-B19	50	50	300	50			CDH3219	HB 5	SHCD53		LW6

Spare parts									
Clamp & Clamp Screw			Shim				Wrench		
HB2	HB3	HB5	SHCD22	SHCD33	SHCD53	LW2.5	LW5	LW6	



EXTERNAL TOOLHOLDER

CVJN

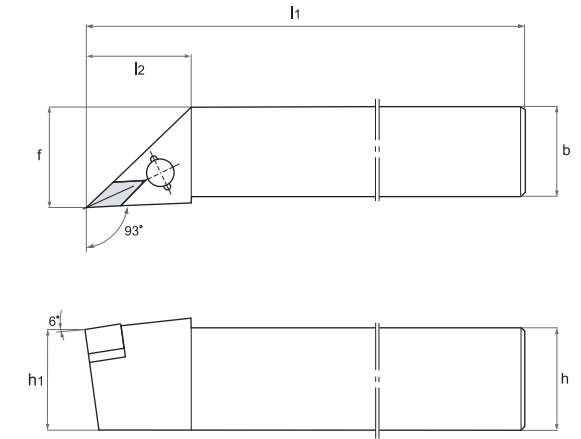
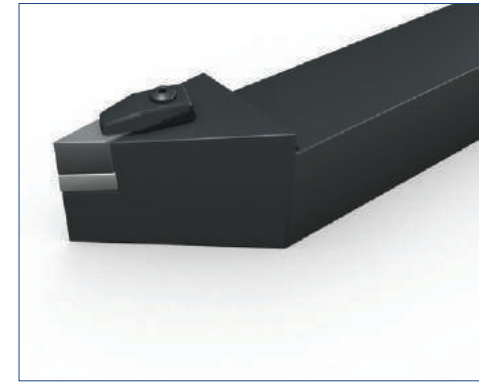

Type	Dimensions (mm)					Stock		Insert	Spare Parts			
	h(h ₁)	b	l ₁	l ₂	f	R	L		Clamp & Clamp Screw	Shim	Shim Screw	Wrench
CVJNR/L 2525M16-A4	25	25	150	41	32	●	●	VNGN1604	UH24S	SHVN3A	TM412	LW4
CVJNR/L 2525M16-X7	25	25	150	41	32	●	●	VNGX1607	UH24S	SHVN3A	TM412	LW4
CVJNR/L 3225P16-X7	32	25	170	41	32	●		VNGX1607	UH24S	SHVN3A	TM412	LW4

Spare parts			
Clamp & Clamp Screw	Shim	Shim Screw	Wrench
UH24, UH24S	SHVN3A	TM412	LW4



EXTERNAL TOOLHOLDER

CVVN

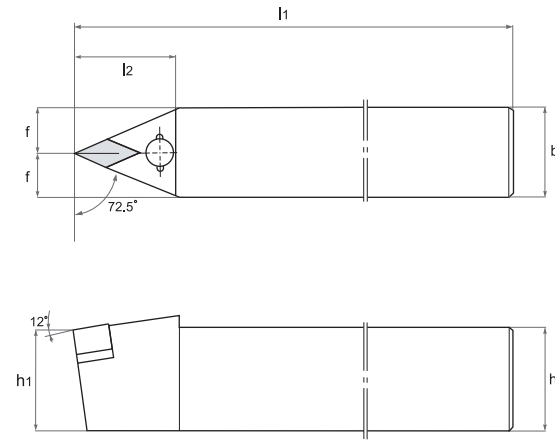
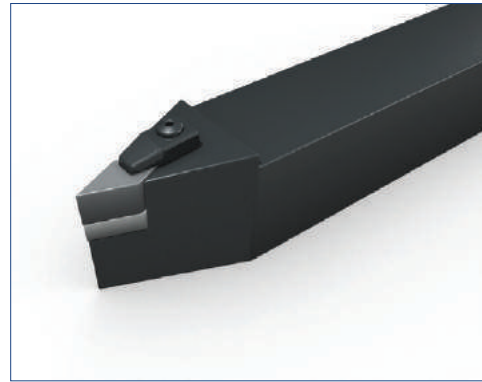

Type	Dimensions (mm)					Stock		Insert	Spare Parts			
	h(h ₁)	b	l ₁	l ₂	f	R	L		Clamp & Clamp Screw	Shim	Shim Screw	Wrench
CVVNN 2525M16-A4	25	25	150	45	12.5			VNGN1604	UH24S	SHVN3A	TM412	LW4
CVVNN 2525M16-X7	25	25	150	45	12.5			VNGX1607	UH24	SHVN3A	TM412	LW4
CVVNN 3225P16-X7	32	25	170	45	12.5		●	VNGX1607	UH24	SHVN3A	TM412	LW4

Spare parts			
Clamp & Clamp Screw	Shim	Shim Screw	Wrench
UH24 UH24S	SHVN3A	TM412	LW4

VNGN	VNGX
Page 49	Page 50

EXTERNAL TOOLHOLDER

CSBF

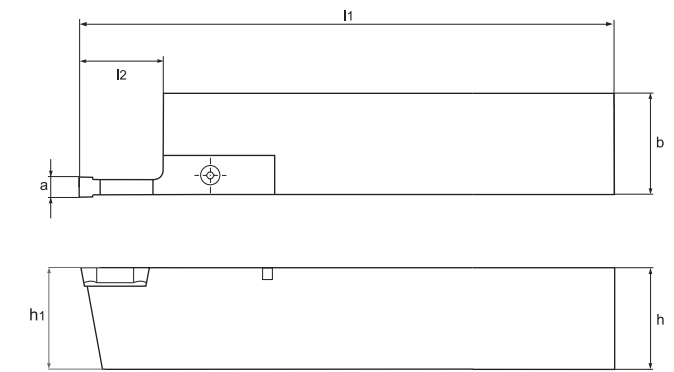

Type	Dimensions (mm)					Stock		Insert	Spare Parts			
	h(h ₁)	b	l ₁	l ₂	f	R	L		Clamp & Clamp Screw	Shim	Shim Screw	Wrench
CSBF 5040P3228R/L	3.18	50	40	170	19			SGD3/LH	SH510	SH510		LW3
CSBF 5040P4828R/L	4.78	50	40	170	19			SGD4/LH	SH510	SH510		LW4
CSBF 5040P5528R/L	5.54	50	40	170	19			SGD4/LH	SH510	SH510		LW4
CSBF 5040P6428R/L	6.35	50	40	170	19			SHD6/LHS	SH510	SH510		LW4
CSBF 5040P7928R/L	7.93	50	40	170	19			GD6/LH	SH510	SH510		LW4
CSBF 5040P9528R/L	9.52	50	40	170	19			SGD9/LH	SH510	SH510		LW5

Spare parts			
Clamp & Clamp Screw		Wrench	
SGD3 / LH	SGD4 / LH SGD6 / LH SGD9 / LH	SH520	LW3 LW4 LW5

SYBF
Page 58

EXTERNAL TOOLHOLDER

CSBR

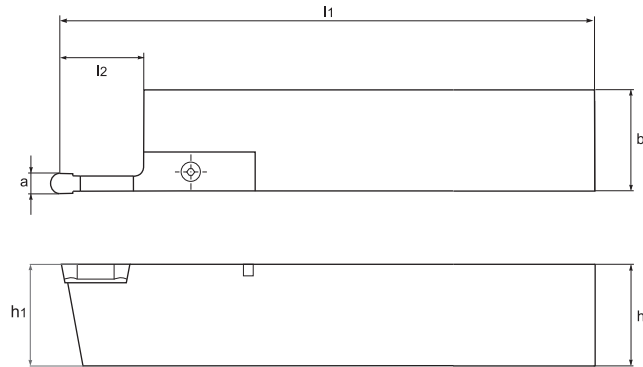

Type	Dimensions (mm)					Stock		Insert	Spare Parts	
	a	h(h ₁)	b	l ₁	l ₂	R	L		Clamp & Clamp Screw	Wrench
CSBR 5040P3228R/L	3.18	50	40	170	19			SYBR3228	SGD3 / LH SH520	LW3
CSBR 5040P4828R/L	4.78	50	40	170	19			SYBR4828	SGD4 / LH SH520	LW4
CSBR 5040P5528R/L	5.54	50	40	170	19			SYBR5528	SGD4 / LH SH520	LW4
CSBR 5040P6428R/L	6.35	50	40	170	19			SYBR6428	SGD6 / LH SH520	LW4
CSBR 5040P7928R/L	7.93	50	40	170	19			SYBR7928	SGD6 / LH SH520	LW4
CSBR 5040P9528R/L	9.52	50	40	170	19			SYBR9528	SGD9 / LH SH520	LW5

Spare parts									
Clamp & Clamp Screw					Wrench				
SGD3 / LH	SGD4 / LH	SGD6 / LH	SGD9 / LH		SH520	LW3	LW4	LW5	



EXTERNAL TOOLHOLDER

CSGF

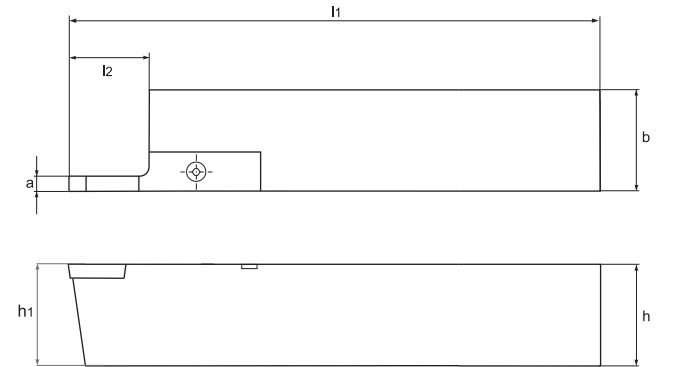
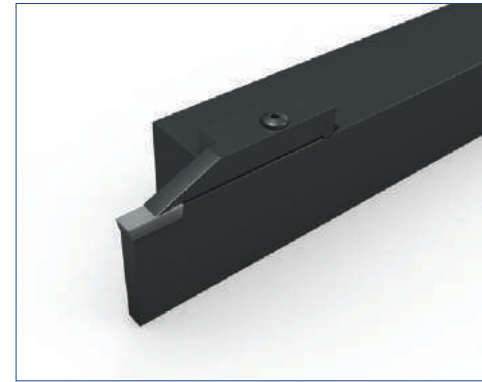

Type	Dimensions (mm)					Stock		Insert	Spare Parts	
	a	h(h ₁)	b	l ₁	l ₂	R	L		Clamp & Clamp Screw	Wrench
CSGF 3225P4012R/L	4.0	32	25	170	19	●		SGF4012	SGL4 / LH SH520	LW3
CSGF 3225P5012R/L	5.0	32	25	170	19	●		SGF5012	SGL5 / LH SH520	LW4
CSGF 3225P6015R/L	6.0	32	25	170	19	●	●	SGF6015	SGL5 / LH SH520	LW4
CSGF 3225P7015R/L	7.0	32	25	170	19	●		SGF7015	SGL7 / LH SH520	LW5
CSGF 3225P8015R/L	8.0	32	25	170	19	●	●	SGF8015	SGL8 / LH SH520	LW5
CSGF 3225P1015R/L	10.0	32	25	170	19			SGF1015	SGL8 / LH SH520	LW5

Spare parts									
Clamp & Clamp Screw					Wrench				
SGL4 / LH	SGL5 / LH	SGL7 / LH	SGL8 / LH		SH520	LW3	LW4	LW5	



EXTERNAL TOOLHOLDER

CSGR

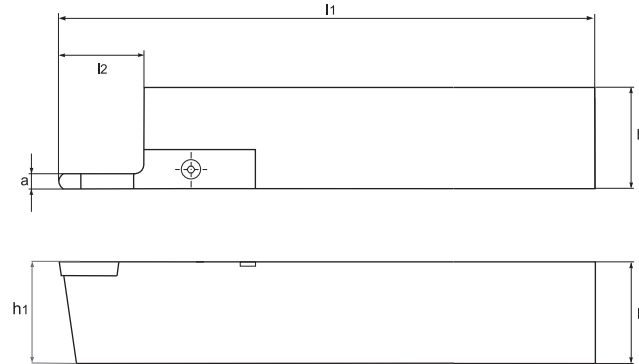

Type	Dimensions (mm)					Stock		Insert	Spare Parts		
	a	h(h ₁)	b	l ₁	l ₂	R	L		Clamp & Clamp Screw		Wrench
CSGR 3225P4012R/L	4.0	32	25	170	19		●	SGR4012	SGL4 / LH	SH520	LW3
CSGR 3225P5012R/L	5.0	32	25	170	19	●		SGR5012	SGL5 / LH	SH520	LW4
CSGR 3225P6015R/L	6.0	32	25	170	19			SGR6015	SGL5 / LH	SH520	LW4
CSGR 3225P7015R/L	7.0	32	25	170	19			SGR7015	SGL7 / LH	SH520	LW5
CSGR 3225P8015R/L	8.0	32	25	170	19			SGR8015	SGL8 / LH	SH520	LW5
CSGR 3225P1015R/L	10.0	32	25	170	19			SGR1015	SGL8 / LH	SH520	LW5

Spare parts											
Clamp & Clamp Screw								Wrench			
SGL4 / LH	SGL5 / LH	SGL7 / LH	SGL8 / LH	SH520	LW3	LW4	LW5				



EXTERNAL TOOLHOLDER

CSSF

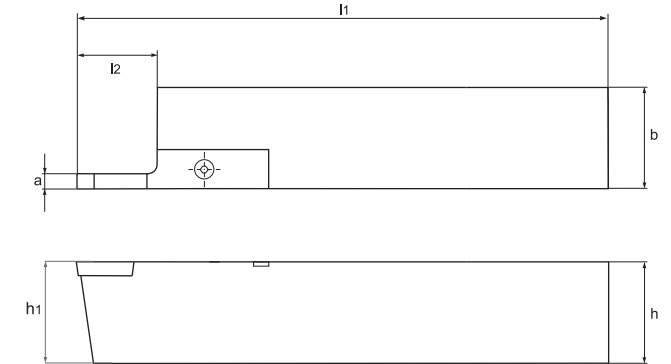
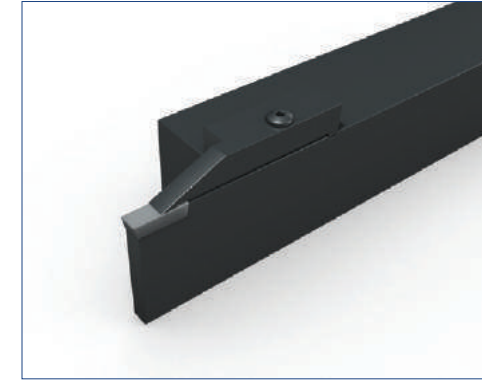

Type	Dimensions (mm)					Stock		Insert	Spare Parts		
	a	h(h ₁)	b	l ₁	l ₂	R	L		Clamp & Clamp Screw		Wrench
CSSF 3225P4012R/L	4.0	32	25	170	19	●	●	SSF4012	SGL4 / LH	SH520	LW3
CSSF 3225P5012R/L	5.0	32	25	170	19	●		SSF5012	SGL5 / LH	SH520	LW4
CSSF 3225P6015R/L	6.0	32	25	170	19	●		SSF6015	SGL5 / LH	SH520	LW4
CSSF 3225P7015R/L	7.0	32	25	170	19			SSF7015	SGL7 / LH	SH520	LW5
CSSF 3225P8015R/L	8.0	32	25	170	19			SSF8015	SGL8 / LH	SH520	LW5
CSSF 3225P1015R/L	10.0	32	25	170	19			SSF1015	SGL8 / LH	SH520	LW5

Spare parts											
Clamp & Clamp Screw								Wrench			
SGL4 / LH	SGL5 / LH	SGL7 / LH	SGL8 / LH	SH520	LW3	LW4	LW5				



EXTERNAL TOOLHOLDER

CSSR

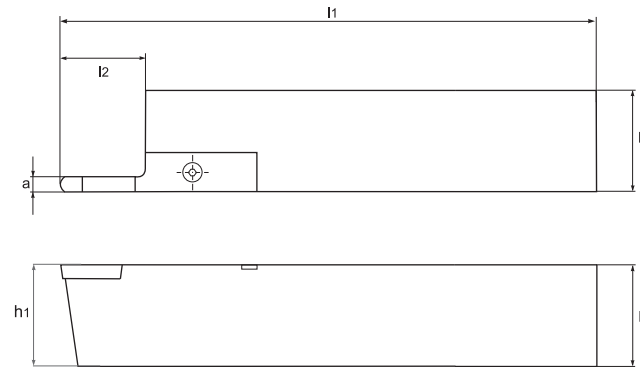
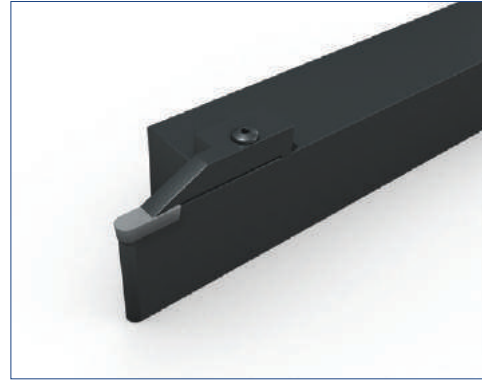

Type	Dimensions (mm)					Stock	Insert	Spare Parts		
	a	h(h ₁)	b	l ₁	l ₂			Clamp & Clamp Screw		Wrench
CSSR 3225P4012R/L	4.0	32	25	170	19		SSR4012	SGL4 / LH	SH520	LW3
CSSR 3225P5012R/L	5.0	32	25	170	19	●	SSR5012	SGL5 / LH	SH520	LW4
CSSR 3225P6015R/L	6.0	32	25	170	19	●	SSR6015	SGL5 / LH	SH520	LW4
CSSR 3225P7015R/L	7.0	32	25	170	19		SSR7015	SGL7 / LH	SH520	LW5
CSSR 3225P8015R/L	8.0	32	25	170	19	●	SSR8015	SGL8 / LH	SH520	LW5
CSSR 3225P1015R/L	10.0	32	25	170	19		SSR1015	SGL8 / LH	SH520	LW5

Spare parts										
Clamp & Clamp Screw					Wrench					
SGL4 / LH	SGL5 / LH	SGL7 / LH	SGL8 / LH	SH520	LW3	LW4	LW5			



EXTERNAL TOOLHOLDER

CSSR .. N

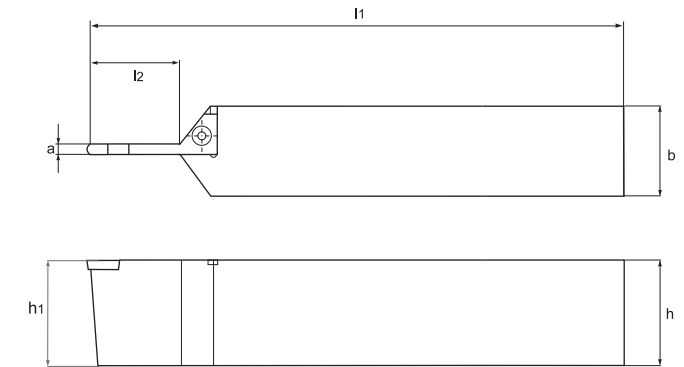
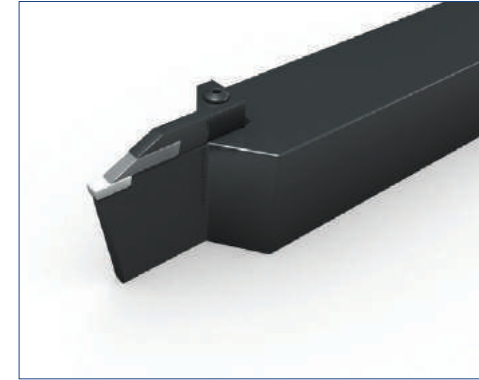

Type	Dimensions (mm)					Stock	Insert	Spare Parts		
	a	h(h ₁)	b	l ₁	l ₂			Clamp & Clamp Screw		Wrench
CSSR 4040R4012.N5	4.0	40	40	200	5		SSR4012	GRW4012	SH520	LW3
CSSR 5040P4012.N19	4.0	50	40	170	19		SSR4012	GRW4012	SH520	LW3

Spare parts		
Clamp & Clamp Screw	Wrench	
GRW4012	SH520	LW4





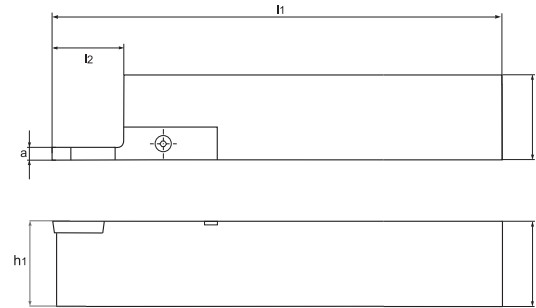
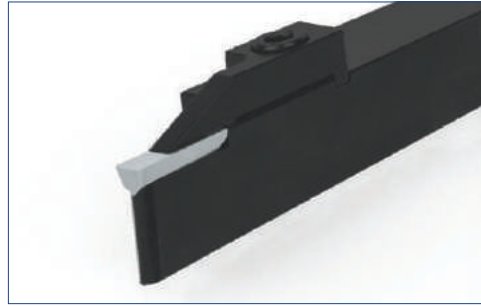

EXTERNAL TOOLHOLDER

CWF/R

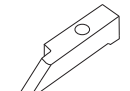

Type	Dimensions (mm)					Stock		Insert	Spare Parts	
	a	h(h ₁)	b	l ₁	l ₂	R	L		Clamp & Clamp Screw	Wrench
CWF/R 2525M094050R/L	2.3	25	25	150	19			WFP094050 WRP094050 WFC094050 WRC094050	WGL2.3 R/L & WCB6	WCS6 LW5
CWF/R 2525M125050R/L	3.1	25	25	150	19	●	●	WFP125050 WRP125050 WFC125050 WRC125050	WGL3.1 R/L & WCB6	WCS6 LW5
CWF/R 2525M156050R/L	3.9	25	25	150	19	●	●	WFP156050 WRP156050 WFC156050 WRC156050	WGL3.9 R/L & WCB6	WCS6 LW5
CWF/R 2525M187050R/L	4.7	25	25	150	19	●	●	WFP187050 WRP187050 WFC187050 WRC187050	WGL4.7 R/L & WCB6	WCS6 LW5
CWF/R 2525M218075R/L	5.5	25	25	150	29	●		WFP218075 WRP218075 WFC218075 WRC218075	WGL5.5 R/L & WCB6	WCS6 LW5
CWF/R 2525M250075R/L	6.3	25	25	150	29	●	●	WFP250075 WRP250075 WFC250075 WRC250075	WGL6.3 R/L & WCB6	WCS6 LW5
CWF/R 2525M281075R/L	7.1	25	25	150	29			WFP281075 WRP281075 WFC281075 WRC281075	WGL7.1 R/L & WCB6	WCS6 LW5
CWF/R 2525M312100R/L	7.9	25	25	150	38			WFP312100 WRP312100 WFC312100 WRC312100	WGL7.9 R/L & WCB6	WCS6 LW5
CWF/R 2525M344100R/L	8.7	25	25	150	38			WFP344100 WRP344100 WFC344100 WRC344100	WGL8.7 R/L & WCB6	WCS6 LW5
CWF/R 2525M375100R/L	9.5	25	25	150	38			WFP375100 WRP375100 WFC375100 WRC375100	WGL9.5 R/L & WCB6	WCS6 LW5



Spare parts			
Clamp & Clamp Screw	Spring	Wrench	
 WGL2.3 R/L~WGL9.5 R/L	 WCB6	 WCS6	 LW5

SPECIAL TOOLHOLDER

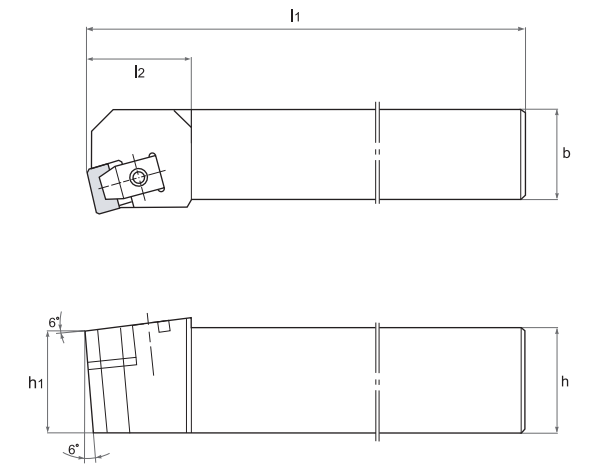
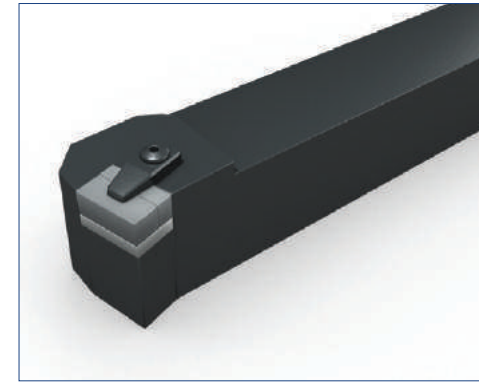
CLKN

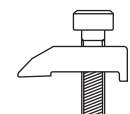
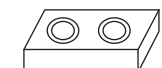

Type	Dimensions (mm)				Stock		Insert	Spare Parts			
	h(h ₁)	b	l ₁	l ₂	R	L		Clamp & Clamp Screw	Shim	Shim Screw	Wrench
CLKNR/L 6060V65-A	60	60	400	70			LNJ6588	SM14	SHLJ5	BM510	LW6
CLKNR/L 6060V66-A	60	60	400	70			LNJ6688	SM14	SHLJ5	BM510	LW6

Spare parts			
Clamp & Clamp Screw	Shim	Shim Screw	Wrench
 SM14	 SHLJ5 SHLJ6	 BM510	 LW6

LNJ



Page 55

SPECIAL TOOLHOLDER

CFLN

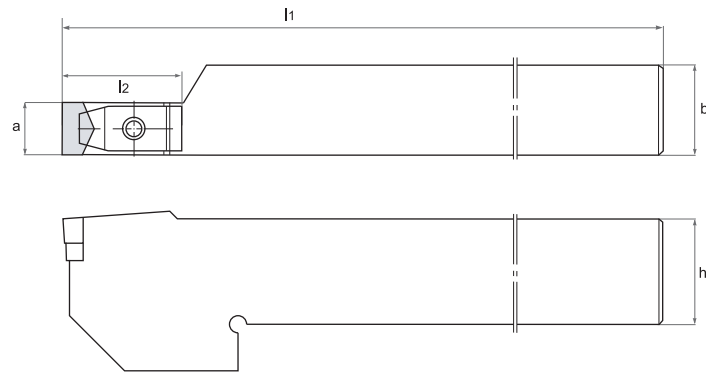
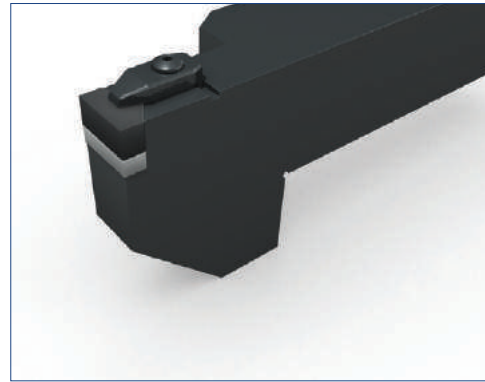

Type	Dimensions (mm)					Stock	Insert	Spare Parts			
	a	h(h ₁)	b	l ₁	l ₂			R	Clamp & Clamp Screw	Shim	Shim Screw
CFLNN 6060U44-A	14	60	60	350	80		F10537	SM14	SHF10	BM510	LW6
CFLNN 5050T32-A	12	50	50	300	75		F13941	SM14	SHF13	BM510	LW6
CFLNN 4040R25-A	7	40	40	200	40		F250723	SM14	SHF25	BM510	LW4

Spare parts					
Clamp & Clamp Screw		Shim		Shim Screw	Wrench
SM14		SHF10	SHF13	SHF25	BM510
					LW8

F-Series	F-Series
Page 53	Page 54

SPECIAL TOOLHOLDER

CSVN

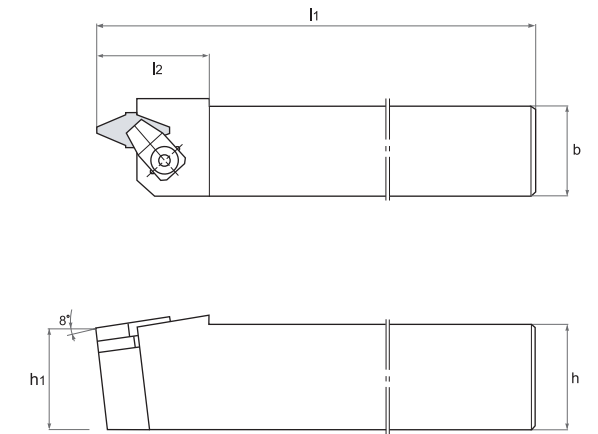
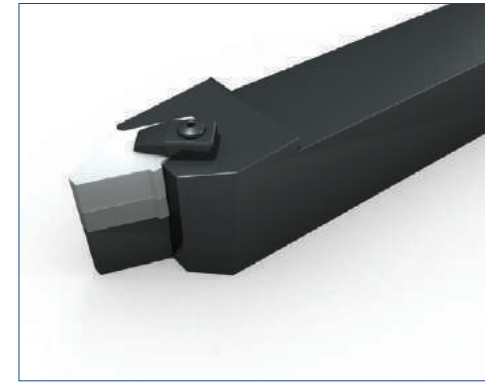

Type	Dimensions (mm)				Stock	Insert	Spare Parts			
	h(h ₁)	b	l ₁	l ₂			R	Clamp & Clamp Screw	Shim	Shim Screw
CSVNN 3232P38-A7-26	32	32	170	38		SVW38260	UH1	SHSV3826	FM510	LW4
CSVNN 3232P38-A7-32	32	32	170	40		SVW38320	UH1	SHSV3832	FM510	LW4
CSVNN 3232P34-A7-40	32	32	170	50		SVW34400	UH1	SHSV3440	FM510	LW4

Spare parts				
Clamp & Clamp Screw	Shim		Shim Screw	Wrench
UH1	SHSV3826	SHSV3832	SHSV3440	FM510
				LW4

SVW
Page 78

SPECIAL TOOLHOLDER

CGVN

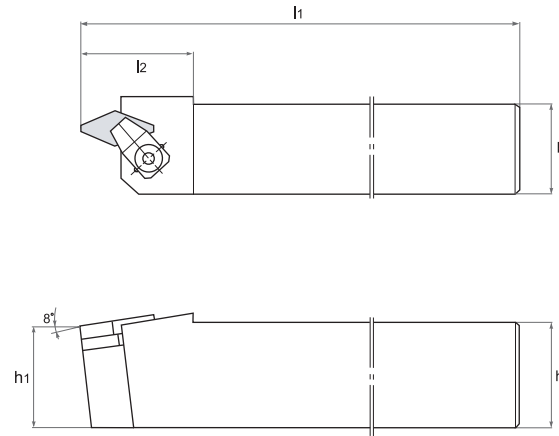
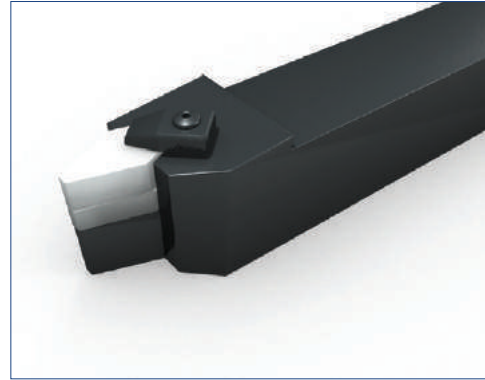

Type	Dimensions (mm)				Stock	Insert	Spare Parts			
	h(h ₁)	b	l ₁	l ₂			Clamp & Clamp Screw	Shim	Shim Screw	Wrench
CGVNN 3232P38-A7-32	32	32	170	48		GVGN38320	UH1	SHGV3832	TM510	LW4
CGVNN 3232P38-A7-33	32	32	170	46		GVGN38335	UH1	SHGV3833	TM510	LW4
CGVNN 3232P36-A7-34	32	32	170	49		GVGN36340	UH1	SHGV3634	TM510	LW4
CGVNN 3232P38-A7-36	32	32	170	44		GVGN38360	UH1	SHGV3836	TM510	LW4
CGVNN 3232P34-A7-36	32	32	170	44		GVGN34360	UH1	SHGV3436	TM510	LW4

Spare parts				
Clamp & Clamp Screw	Shim		Shim Screw	Wrench
UH1	SHGV3832 SHGV3836	SHGV3833 SHGV3436	SHGV3634	TM510 LW4

GVGN

Page 78

SPECIAL TOOLHOLDER

CINN

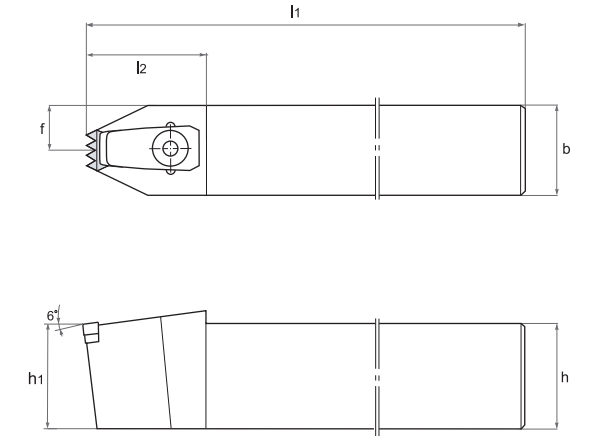
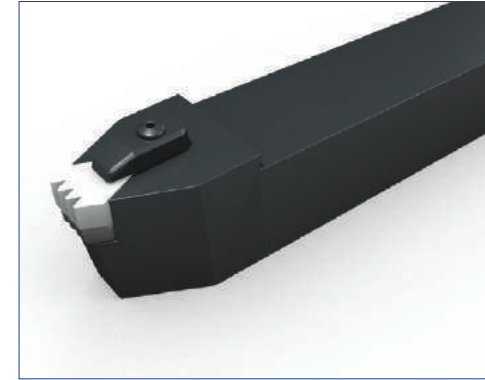

Type	Dimensions (mm)					Stock	Insert	Spare Parts			
	h(h ₁)	b	l ₁	l ₂	f			Clamp & Clamp Screw	Shim	Shim Screw	Wrench
CINNN 2525M09-A4-F3	25	25	150	30	12.5	●	INGN160435F3	UH1	SHIN33F3	TM3008	LW4
CINNN 2525M12-A4-F4	25	25	150	34	12.5	●	INGN220435F4	UH1	SHIN43F4	TM4010	LW4
CINNN 3225P09-A4-F3	32	25	170	30	12.5		INGN160435F3	UH1	SHIN33F3	TM3008	LW4
CINNN 3225P12-A4-F4	32	25	170	34	12.5		INGN220435F4	UH1	SHIN43F4	TM4010	LW4

Spare parts				
Clamp & Clamp Screw	Shim		Shim Screw	Wrench
UH1	SHIN33F3	SHIN43F4	TM3008 TM4010	LW4

INGN

Page 80

INGN

Page 103

ROLL TOOLING SOLUTION

PLATE MILL ROLL

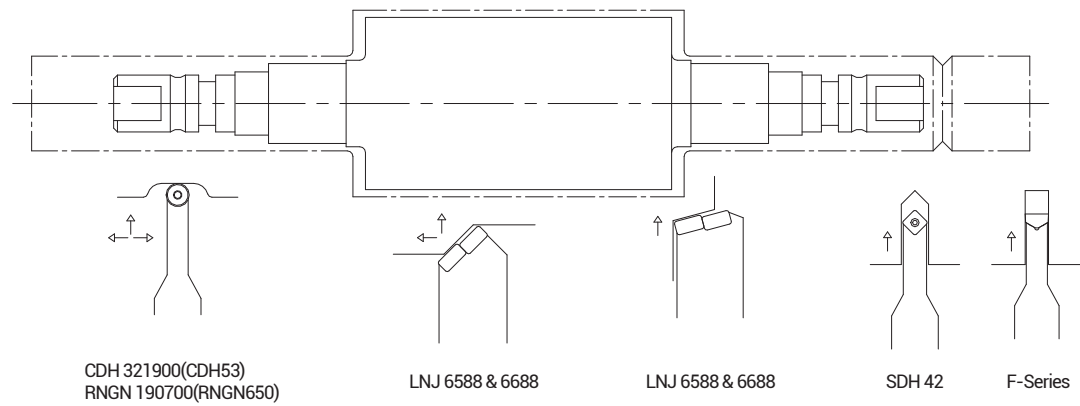

CDH 321900(CDH53)
RNGN 190700(RNGN650)

LNJ 6588 & 6688

LNJ 6588 & 6688

SDH 42

F-Series

SECTION MILL

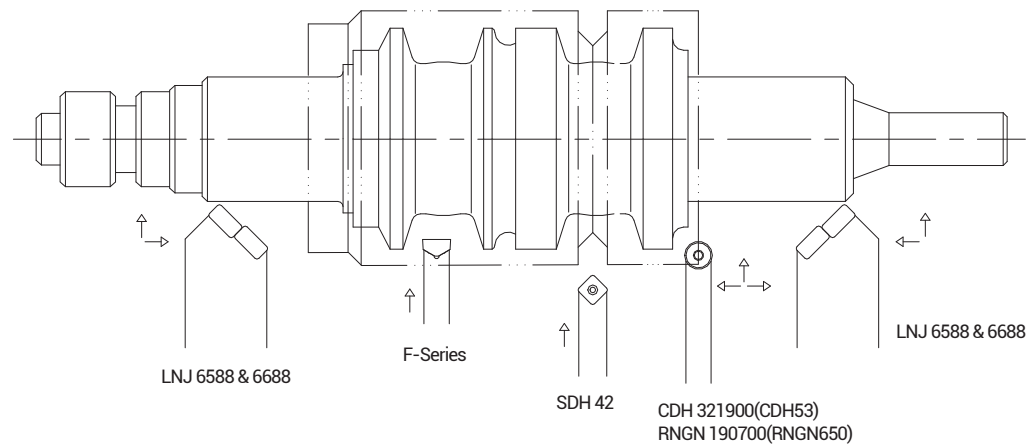

LNJ 6588 & 6688

F-Series

SDH 42

CDH 321900(CDH53)
RNGN 190700(RNGN650)

LNJ 6588 & 6688

ROLL TOOLING SOLUTION / SPECIAL TYPE

CARTRIDGE TYPE (INSERT : CDH 321900)

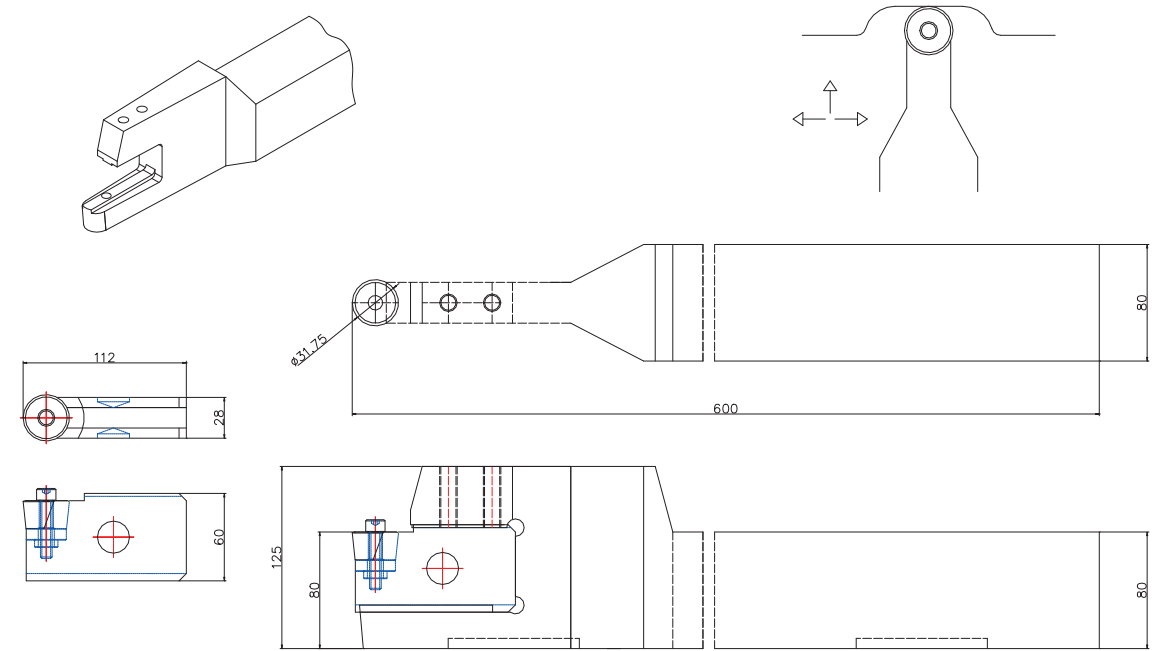

Heavy Duty Roll Cutting Tool / HEINLEIL

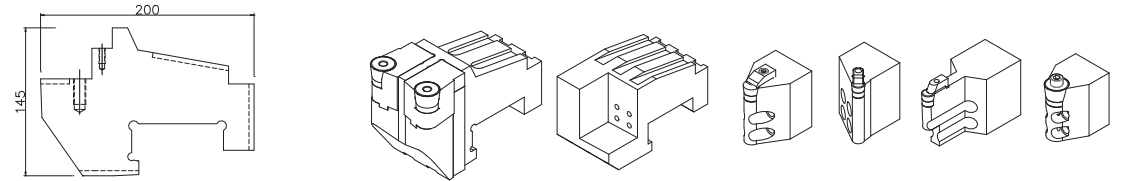

Heavy Duty Roll Cutting Tool / WALDRICH SIEGEN

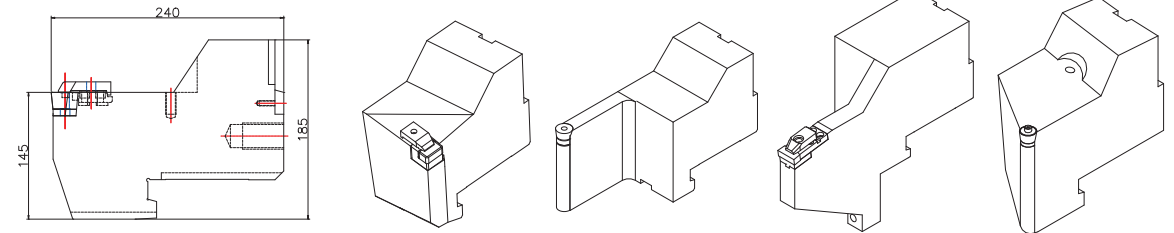

Heavy Duty Roll Cutting Tool / RAVENSBURG

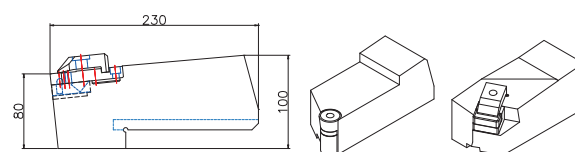

CBN INSERT TOOL & HOLDER

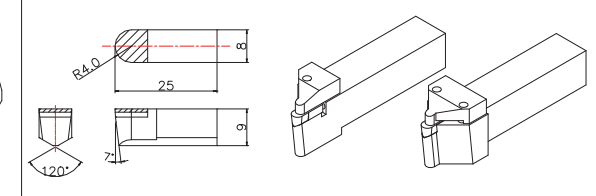

ROLL TOOLING SOLUTION / SPECIAL TYPE

CARTRIDGE TYPE (INSERT : CDH 321900)

MILLING CUTTER



Application Index A 190

Face Milling Cutter A 192

Ball Endmill A 230

Chamfer Cutter A 232

Aluminum Cutter A 235

Special Tools A 244

APPLICATION INDEX

TURNING
&
MILLING

CERAMIC

CERMET

PCBN / PCD

TOOL HOLDER

MILLING CUTTER

SFKN .. 88



PAGE 192

SFKN .. 75



PAGE 194

SFKN .. 45



PAGE 196

SFKP .. 88



PAGE 198

SFKP .. 75



PAGE 200

SFKP .. 45



PAGE 202

SFAN .. 88



PAGE 204

SFAN .. 75



PAGE 206

SFSX .. 00 .. EC



PAGE 208

SFSX .. 70 .. EC



PAGE 210

SFSP .. OT



PAGE 212

SFKN .. HX



PAGE 214

SFKP .. MF



PAGE 216

SFMS .. LRF



PAGE 218

SFCN .. 00 .. R



PAGE 220

SFCP .. 00 .. R



PAGE 222

SFKN .. 90



PAGE 228

SEXP



PAGE 232

HPA-H



PAGE 238

QCB-I



PAGE 243

SFXN



PAGE 224

SMCD .. 90



PAGE 229

CSC



PAGE 234

HPA-M



PAGE 239

QCB-H



PAGE 244

SFXP



PAGE 226

SECP



PAGE 230

HPA-I



PAGE 237

ARBOR



PAGE 240

TURNING
&
MILLING

CERAMIC

CERMET

PCBN / PCD

TOOL HOLDER

MILLING CUTTER

FACE MILLING CUTTER

SFKN .. 88



Axial rake angle : -7°

Radial rake angle
D40 : -12°
D50~125 : -10°

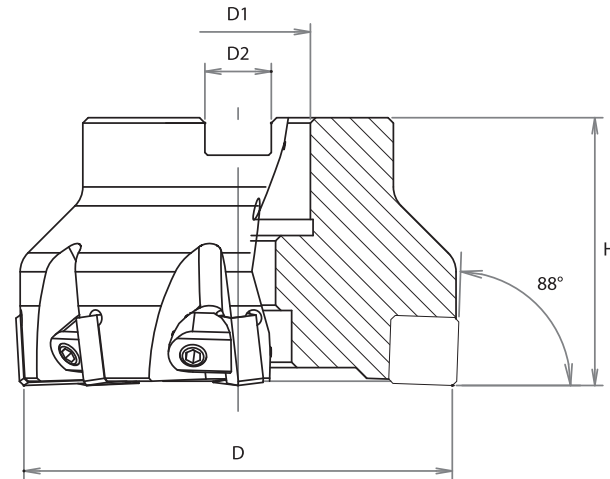

Type	Dimensions (mm)				Z	Insert
	D	D ₁	D ₂	H		
SFKN 040-04-88 N4	40	16	8.4	40	4	SNCN 0904 ZYT
SFKN 050-05-88 N4	50	22	10.4	40	5	
SFKN 063-06-88 N4	63	22	10.4	40	6	SNCN 1204 ZYT SNCN 1204 ZN
SFKN 080-08-88 N4A	80	25.4	9.5	50	8	
SFKN 080-08-88 N4	80	27	12.4	50	8	
SFKN 100-10-88 N4A	100	31.75	12.7	50	10	
SFKN 100-10-88 N4	100	32	14.4	50	10	
SFKN 125-12-88 N4A	125	38.1	15.9	63	12	
SFKN 125-12-88 N4	125	40	16.4	63	12	

Dimensions (mm) D	Spare parts		
	Wedge	Wedge Screw	Wrench
40 - 50	SSW9	WS6 (M6)	LW3
63 - 125	SSW10	WS6 (M6)	LW3

Recommended Cutting Condition for Gray Cast Iron

Process	Hardness (HB)	Cutting Speed Vc(m/min)	Feed fz(mm/z)	Depth ap(mm)	Surface Quality Ra(μm)
Roughing	190~210	800~2,000	0.08~0.15	2.0~5.0	6.3~12.5
Roughing	220~240	500~1,500	0.08~0.15	2.0~5.0	6.3~12.5
Roughing	250~280	300~1,200	0.08~0.15	2.0~5.0	6.3~12.5

SNCN .. ZYT

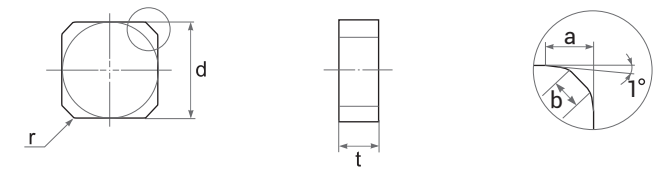

Type		Dimensions (mm)				ST100	ST300	ST500	ST900	TC300	TM300	SD200	SZ200	SZ300	SN26	SN300	SN400	SN500	SN600	SN800	SNT1000	NC400	SW400	SW800
ISO	ASA	d	t	a	b																			
SNCN 0904 ZYT	SNCN 33 ZYT	9.52	4.76	1.30	1.10												●	●		●	●			
SNCN 1204 ZYT	SNCN 43 ZYT	12.70	4.76	3.25	1.10												●	●		●	●			

SNCN .. ZN

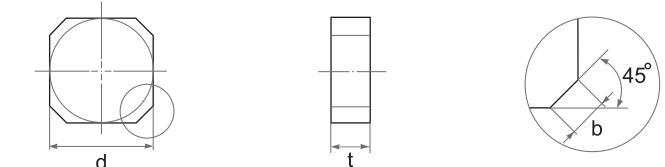

Type		Dimensions (mm)			ST100	ST300	ST500	ST900	TC300	TM300	SD200	SZ200	SZ300	SN26	SN300	SN400	SN500	SN600	SN800	SNT1000	NC400	SW400	SW800	
ISO	ASA	d	t	b																				
SNCN 1204 ZN	SNCN 43 ZN	12.70	4.76	1.10												●								

FACE MILLING CUTTER

SFKN .. 75



Axial rake angle : -6°

Radial rake angle : -10°

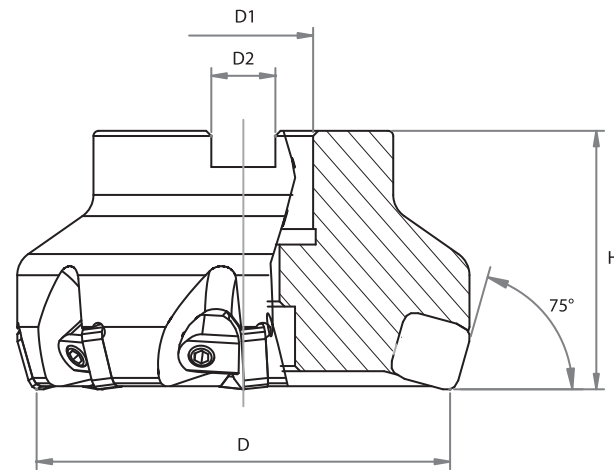

Type	Dimensions (mm)				⚙️	Insert
	D	D ₁	D ₂	H		
SFKN 050-05-75 N4	50	22	10.4	40	5	SNCN 1204 ENTN SNGN 1204 □□
SFKN 063-06-75 N4	63	22	10.4	40	6	
SFKN 080-08-75 N4A	80	25.4	9.5	50	8	
SFKN 080-08-75 N4	80	27	12.4	50	8	
SFKN 100-10-75 N4A	100	31.75	12.7	50	10	
SFKN 100-10-75 N4	100	32	14.4	50	10	
SFKN 125-12-75 N4A	125	38.1	15.9	63	12	
SFKN 125-12-75 N4	125	40	16.4	63	12	

Dimensions (mm) D	Spare parts		
	Wedge	Wedge Screw	Wrench
50	SSW10	WS6 (M6)	LW3
63 - 125	SSW10	WS6 (M6)	LW3

Recommended Cutting Condition for Gray Cast Iron

Process	Hardness (HB)	Cutting Speed Vc(m/min)	Feed fz(mm/z)	Depth ap(mm)	Surface Quality Ra(μm)
Roughing	190~210	800~2,000	0.10~0.20	2.0~5.0	6.3~12.5
Roughing	220~240	500~1,500	0.10~0.20	2.0~5.0	6.3~12.5
Roughing	250~280	300~1,200	0.10~0.20	2.0~5.0	6.3~12.5

SNCN .. ENTN

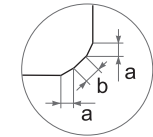
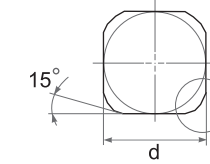

Type		Dimensions (mm)					ST100	ST300	ST500	ST900	TC300	TM300	SD200	SZ200	SZ300	SN26	SN300	SN400	SN500	SN600	SN800	SN1000	NC400	SW400	SW800
ISO	ASA	d	t	a	b																				
SNCN 1204 ENTN	SNCN 43 ENTN	12.70	4.76	1.40	1.00											●	●	●							

SNGN

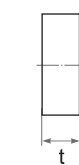
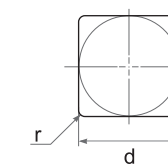

Type		Dimensions (mm)			ST100	ST300	ST500	ST900	TC300	TM300	SD200	SZ200	SZ300	SN26	SN300	SN400	SN500	SN600	SN800	SN1000	NC400	SW400	SW800
ISO	ASA	d	t	r																			
SNGN 120412	SNGN 433	12.70	4.76	1.2												●							
SNGN 120416	SNGN 434	12.70	4.76	1.6												●							

FACE MILLING CUTTER

SFKN .. 45



Axial rake angle : -6°

Radial rake angle : -12°

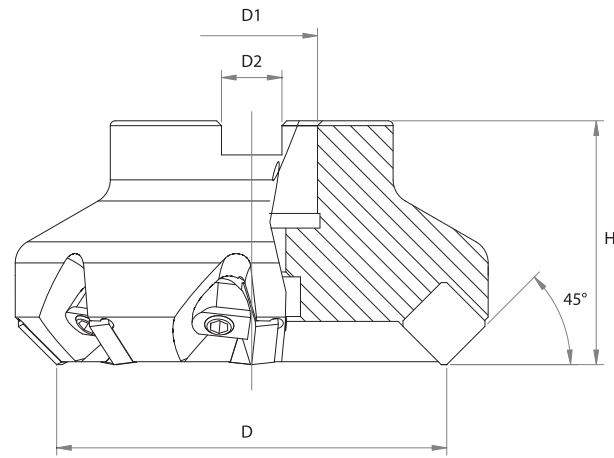

Type	Dimensions (mm)				⚙️	Insert
	D	D ₁	D ₂	H		
SFKN 050-05-45 N4	50	22	10.4	40	5	SNCN 1204 AN SNCN 1204 ZN SNGN 1204 □□
SFKN 063-06-45 N4	63	22	10.4	40	6	
SFKN 080-08-45 N4A	80	25.4	9.5	50	8	
SFKN 080-08-45 N4	80	27	12.4	50	8	
SFKN 100-10-45 N4A	100	31.75	12.7	50	10	
SFKN 100-10-45 N4	100	32	14.4	50	10	
SFKN 125-12-45 N4A	125	38.1	15.9	63	12	
SFKN 125-12-45 N4	125	40	16.4	63	12	

Dimensions (mm) D	Spare parts		
	Wedge	Wedge Screw	Wrench
50	SSW10	WS6 (M6)	LW3
63 - 125	SSW10	WS6 (M6)	LW3

Recommended Cutting Condition for Gray Cast Iron

Process	Hardness (HB)	Cutting Speed Vc(m/min)	Feed fz(mm/z)	Depth ap(mm)	Surface Quality Ra(μm)
Roughing	190~210	800~2,000	0.15~0.30	2.0~5.0	3.2~12.5
Roughing	220~240	500~1,500	0.15~0.30	2.0~5.0	3.2~12.5
Roughing	250~280	300~1,200	0.15~0.30	2.0~5.0	3.2~12.5

SNCN

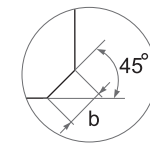
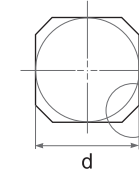

Type		Dimensions (mm)			ST100	ST300	ST500	ST900	TC300	TM300	SD200	SZ200	SZ300	SN26	SN300	SN400	SN500	SN600	SN800	SNT1000	NC400	SW400	SW800
ISO	ASA	d	t	b																			
SNCN 1204 AN	SNCN 43 AN	12.70	4.76	2.50												●							
SNCN 1204 ZN	SNCN 43 ZN	12.70	4.76	1.10												●							

SNGN

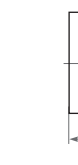
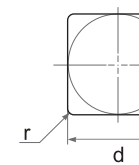

Type		Dimensions (mm)			ST100	ST300	ST500	ST900	TC300	TM300	SD200	SZ200	SZ300	SN26	SN300	SN400	SN500	SN600	SN800	SNT1000	NC400	SW400	SW800
ISO	ASA	d	t	r																			
SNGN 120412	SNGN 433	12.70	4.76	1.2												●							
SNGN 120416	SNGN 434	12.70	4.76	1.6												●							

FACE MILLING CUTTER

SFKP .. 88



Axial rake angle : +7°

Radial rake angle : +3°

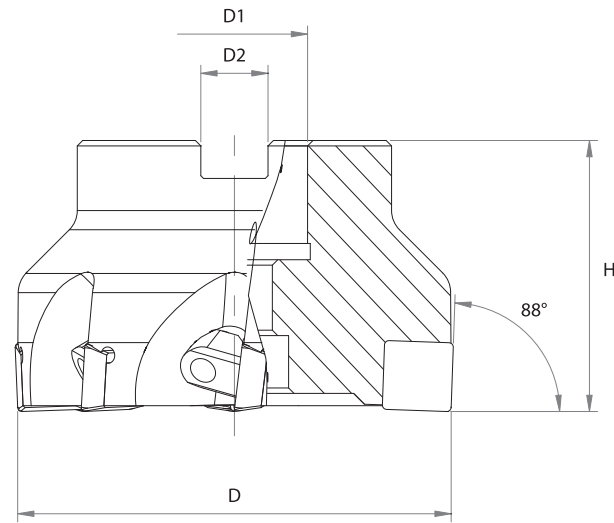

Type	Dimensions (mm)				⚙️	Insert
	D	D ₁	D ₂	H		
SFKP 050-05-88 N4	50	22	10.4	40	5	SDCN 1204 □ □ T20
SFKP 063-06-88 N4	63	22	10.4	40	6	
SFKP 080-08-88 N4A	80	25.4	9.5	50	8	
SFKP 080-08-88 N4	80	27	12.4	50	8	
SFKP 100-10-88 N4A	100	31.75	12.7	50	10	
SFKP 100-10-88 N4	100	32	14.4	50	10	
SFKP 125-12-88 N4A	125	38.1	15.9	63	12	
SFKP 125-12-88 N4	125	40	16.4	63	12	

Dimensions (mm) D	Spare parts		
	Wedge	Wedge Screw	Wrench
50	SSW9	WS6 (M6)	LW3
63 - 125	SSW10	WS6 (M6)	LW3

Recommended Cutting Condition for Gray Cast Iron

Process	Hardness (HB)	Cutting Speed Vc(m/min)	Feed fz(mm/z)	Depth ap(mm)	Surface Quality Ra(μm)
Roughing	190~210	800~2,000	0.08~0.15	2.0~5.0	6.3~12.5
Roughing	220~240	500~1,500	0.08~0.15	2.0~5.0	6.3~12.5
Roughing	250~280	300~1,200	0.08~0.15	2.0~5.0	6.3~12.5

SDCN .. T

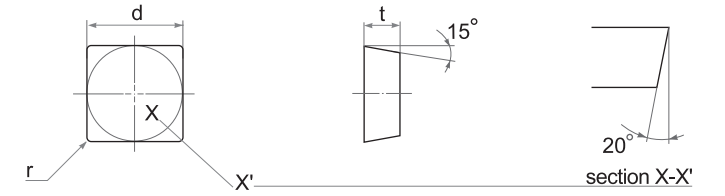

Type		Dimensions (mm)			ST100	ST300	ST500	ST900	TC300	TM300	SD200	SZ200	SZ300	SN26	SN300	SN400	SN500	SN600	SN800	SNT1000	NC400	SW400	SW800
ISO	ASA	d	t	r																			
SDCN 120408 T20	SDCN 432 T20	12.70	4.76	0.8												●							
SDCN 120412 T20	SDCN 433 T20	12.70	4.76	1.2												●							

FACE MILLING CUTTER

SFKP .. 75



Axial rake angle : +5°

Radial rake angle : 0°

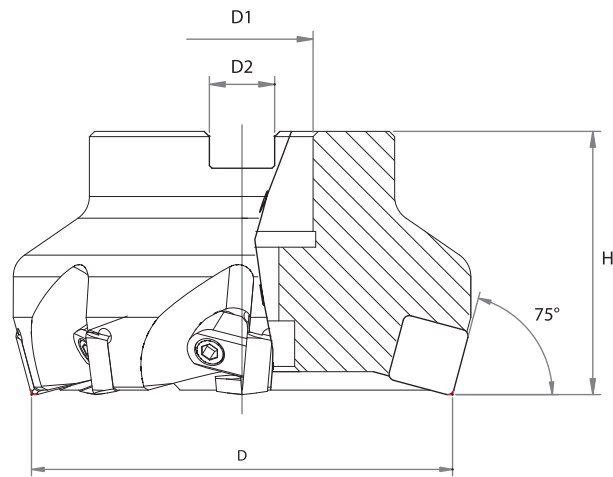

Type	Dimensions (mm)				Z	Insert
	D	D ₁	D ₂	H		
SFKP 050-05-75 N4	50	22	10.4	40	5	SPCN 1204 □ T15 SPKN 1204SP EDTR
SFKP 063-06-75 N4	63	22	10.4	40	6	
SFKP 080-08-75 N4A	80	25.4	9.5	50	8	
SFKP 080-08-75 N4	80	27	12.4	50	8	
SFKP 100-10-75 N4A	100	31.75	12.7	50	10	
SFKP 100-10-75 N4	100	32	14.4	50	10	
SFKP 125-12-75 N4A	125	38.1	15.9	63	12	
SFKP 125-12-75 N4	125	40	16.4	63	12	

Dimensions (mm) D	Spare parts		
	Wedge	Wedge Screw	Wrench
50	SSW9	WS6 (M6)	LW3
63 - 125	SSW10	WS6 (M6)	LW3

Recommended Cutting Condition for Gray Cast Iron

Process	Hardness (HB)	Cutting Speed Vc(m/min)	Feed fz(mm/z)	Depth ap(mm)	Surface Quality Ra(μm)
Roughing	190~210	800~2,000	0.10~0.20	2.0~5.0	3.2~12.5
Roughing	220~240	500~1,500	0.10~0.20	2.0~5.0	3.2~12.5
Roughing	250~280	300~1,200	0.10~0.20	2.0~5.0	3.2~12.5

SPCN .. T

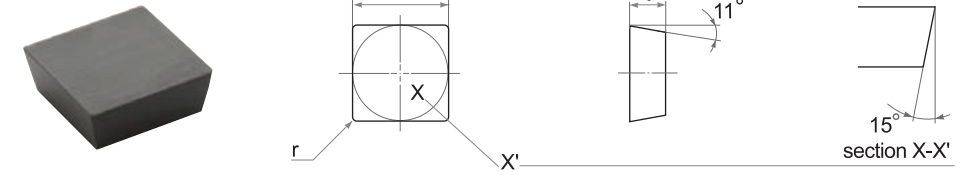

Type		Dimensions (mm)			ST100	ST300	ST500	ST900	TC300	TM300	SD200	SZ200	SZ300	SN26	SN300	SN400	SN500	SN600	SN800	SNT1000	NC400	SW400	SW800
ISO	ASA	d	t	r																			
SPCN 120412 T15	SPCN 433 T15	12.70	4.76	1.2												●							
SPCN 120416 T15	SPCN 434 T15	12.70	4.76	1.6												●							

SPKN .. SP

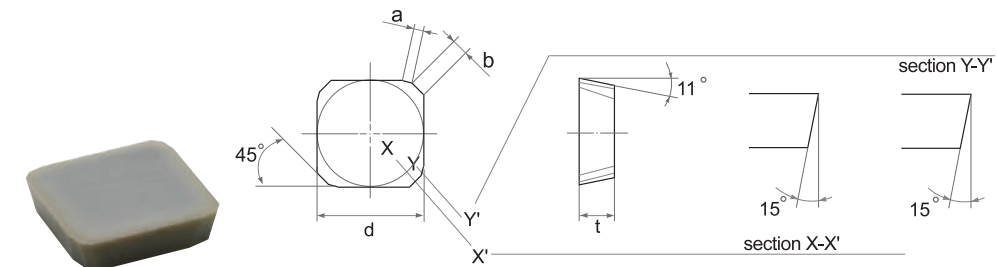

Type		Dimensions (mm)				ST100	ST300	ST500	ST900	TC300	TM300	SD200	SZ200	SZ300	SN26	SN300	SN400	SN500	SN600	SN800	SNT1000	NC400	SW400	SW800
ISO	ASA	d	t	a	b																			
SPKN 1204SP EDTR	SPKN 43SP EDTR	12.70	4.76	1.10	1.30												●							

FACE MILLING CUTTER

SFKP .. 45



Axial rake angle : +19°

Radial rake angle : -6°

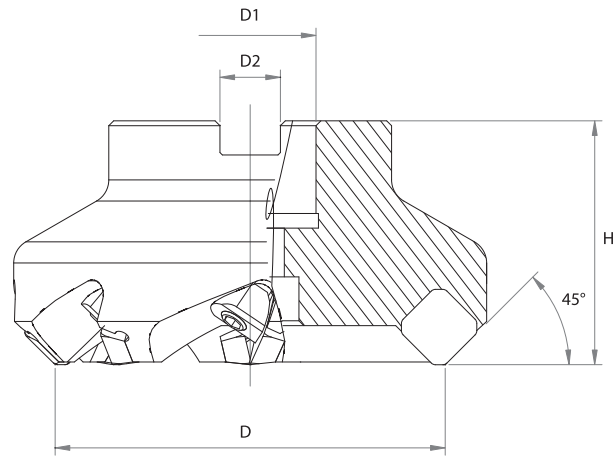

Type	Dimensions (mm)				⚙️	Insert
	D	D ₁	D ₂	H		
SFKP 050-05-45 N4	50	22	10.4	40	5	SEAN 1204 AFTN W25 SEAN 1204 □□T25
SFKP 063-06-45 N4	63	22	10.4	40	6	
SFKP 080-08-45 N4A	80	25.4	9.5	50	8	
SFKP 080-08-45 N4	80	27	12.4	50	8	
SFKP 100-10-45 N4A	100	31.75	12.7	50	10	
SFKP 100-10-45 N4	100	32	14.4	50	10	
SFKP 050-05-45 N3	50	22	10.4	40	5	SEAN 1203 NWAFTN SEAN 1203 AFTN
SFKP 063-06-45 N3	63	22	10.4	40	6	
SFKP 080-08-45 N3A	80	25.4	9.5	50	8	
SFKP 080-08-45 N3	80	27	12.4	50	8	
SFKP 100-10-45 N3A	100	31.75	12.7	50	10	
SFKP 100-10-45 N3	100	32	14.4	50	10	

Dimensions (mm)	Spare parts		
	Wedge	Wedge Screw	Wrench
D			
50	SSW9	WS6 (M6)	LW3
63 - 100	SSW10	WS6 (M6)	LW3

Recommended Cutting Condition for Gray Cast Iron

Process	Hardness (HB)	Cutting Speed Vc(m/min)	Feed fz(mm/z)	Depth ap(mm)	Surface Quality Ra(μm)
Roughing	190~210	800~2,000	0.15~0.30	2.0~5.0	6.3~12.5
Roughing	220~240	500~1,500	0.15~0.30	2.0~5.0	6.3~12.5
Roughing	250~280	300~1,200	0.15~0.30	2.0~5.0	6.3~12.5

SEAN

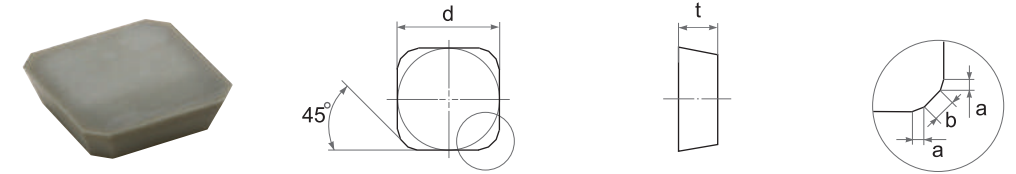

Type		Dimensions (mm)				ST100	ST300	ST500	ST900	TC300	TM300	SD200	SZ200	SZ300	SN26	SN300	SN400	SN500	SN600	SN800	SNT1000	NC400	SW400	SW800
ISO	ASA	d	t	a	b																			
SEAN 1203 AFTN	SEAN 42 AFTN	12.70	3.18	0.50	1.80										●	●	●							

SEAN .. NW

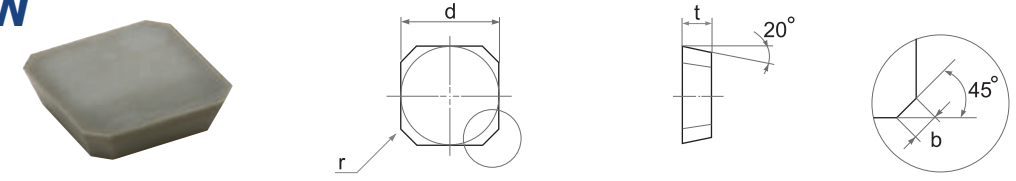

Type		Dimensions (mm)				ST100	ST300	ST500	ST900	TC300	TM300	SD200	SZ200	SZ300	SN26	SN300	SN400	SN500	SN600	SN800	SNT1000	NC400	SW400	SW800
ISO	ASA	d	t	b	r																			
SEAN 1203 NWAFTN	SEAN 42 NWAFTN	12.70	3.18	2.40	0.4										●									
SEAN 1204 AFTNW25	SEAN 43 AFTNW25	12.70	4.76	2.50	1.2												●							

SEAN .. T

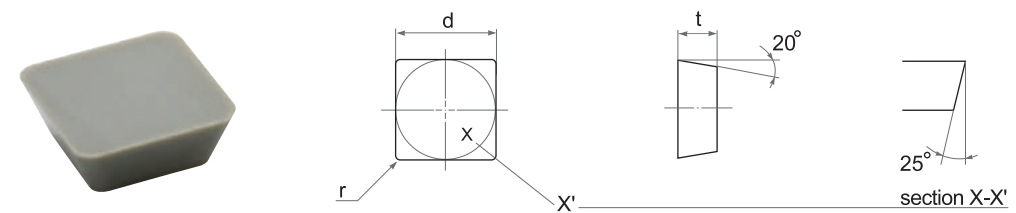

Type		Dimensions (mm)				ST100	ST300	ST500	ST900	TC300	TM300	SD200	SZ200	SZ300	SN26	SN300	SN400	SN500	SN600	SN800	SNT1000	NC400	SW400	SW800
ISO	ASA	d	t	a																				
SEAN 120412 T25	SEAN 433 T25	12.70	4.76	1.2													●					●		
SEAN 120416 T25	SEAN 434 T25	12.70	4.76	1.6													●					●		

FACE MILLING CUTTER

SFAN .. 88



Axial rake angle : -7°

Radial rake angle : -10°

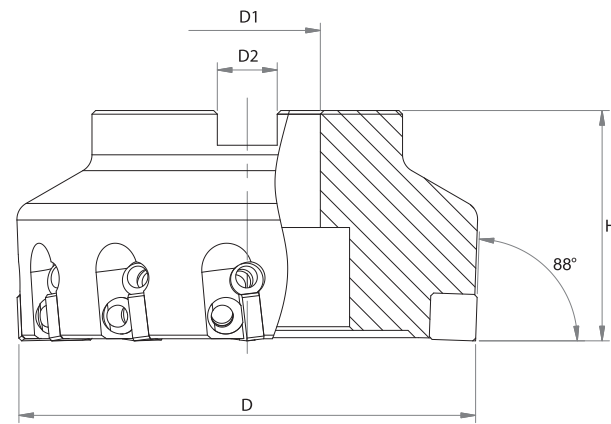

Type	Dimensions (mm)				⚙️	Insert
	D	D ₁	D ₂	H		
SFAN 063-06-88 N4	63	22	10.4	40	6	SNCN 1204 ZYT SNCN 1204 ZN
SFAN 080-08-88 N4A	80	25.4	9.5	50	8	
SFAN 080-08-88 N4	80	27	12.4	50	8	
SFAN 100-10-88 N4A	100	31.75	12.7	50	10	
SFAN 100-10-88 N4	100	32	14.4	50	10	
SFAN 125-12-88 N4A	125	38.1	15.9	63	12	
SFAN 125-12-88 N4	125	40	16.4	63	12	

Dimensions (mm)	Spare parts					
	D	Wedge	Wedge Screw	Adjust Wedge	Adjust Wedge Screw	Wrench
63 - 125						
	SW16	WS6 (M6)	SAW 20	WS6 (M6)	LW3	

Recommended Cutting Condition for Gray Cast Iron

Process	Hardness (HB)	Cutting Speed Vc(m/min)	Feed fz(mm/z)	Depth ap(mm)	Surface Quality Ra(μm)
Roughing	190~210	800~2,000	0.08~0.15	2.0~5.0	6.3~12.5
Roughing	220~240	500~1,500	0.08~0.15	2.0~5.0	6.3~12.5
Roughing	250~280	300~1,200	0.08~0.15	2.0~5.0	6.3~12.5
Finishing	190~210	200~900	0.05~0.10	0.1~0.5	0.8
Finishing	220~240	200~700	0.05~0.10	0.1~0.5	0.8
Finishing	250~280	200~500	0.05~0.10	0.1~0.5	0.8

SNCN .. ZYT

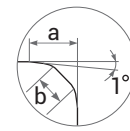
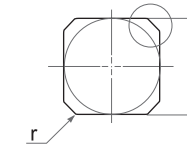

Type		Dimensions (mm)				ST100	ST300	ST500	ST900	TC300	TM300	SD200	SZ200	SZ300	SN26	SN300	SN400	SN500	SN600	SN800	SNT1000	NC400	SW400	SW800
ISO	ASA	d	t	a	b																			
SNCN 1204 ZYT	SNCN 43 ZYT	12.70	4.76	3.25	1.10		●										●	●		●	●			

SNCN .. ZN

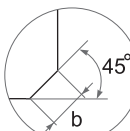
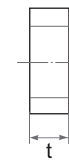
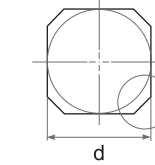

Type		Dimensions (mm)			ST100	ST300	ST500	ST900	TC300	TM300	SD200	SZ200	SZ300	SN26	SN300	SN400	SN500	SN600	SN800	SNT1000	NC400	SW400	SW800
ISO	ASA	d	t	b																			
SNCN 1204 ZN	SNCN 43 ZN	12.70	4.76	1.10												●							

FACE MILLING CUTTER

SFAN .. 75



Axial rake angle : -6°
Radial rake angle : -10°

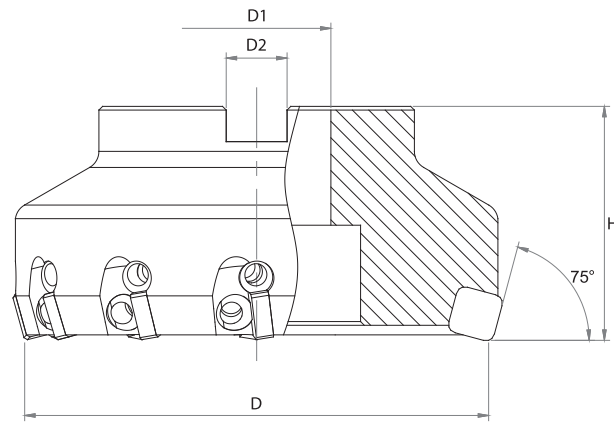

Type	Dimensions (mm)				⚙️	Insert
	D	D ₁	D ₂	H		
SFAN 063-06-75 N4	63	22	10.4	40	6	SNCN 1204 ENTN SNGN 1204 □□
SFAN 080-08-75 N4A	80	25.4	9.5	50	8	
SFAN 080-08-75 N4	80	27	12.4	50	8	
SFAN 100-10-75 N4A	100	31.75	12.7	50	10	
SFAN 100-10-75 N4	100	32	14.4	50	10	
SFAN 125-12-75 N4A	125	38.1	15.9	63	12	
SFAN 125-12-75 N4	125	40	16.4	63	12	

Dimensions (mm)	Spare parts					
	D	Wedge	Wedge Screw	Adjust Wedge	Adjust Wedge Screw	Wrench
63 - 125						
	SW16	WS6 (M6)	SAW 20	WS6 (M6)	LW3	

Recommended Cutting Condition for Gray Cast Iron

Process	Hardness (HB)	Cutting Speed Vc(m/min)	Feed fz(mm/z)	Depth ap(mm)	Surface Quality Ra(μm)
Roughing	190~210	800~2,000	0.08~0.15	2.0~5.0	6.3~12.5
Roughing	220~240	500~1,500	0.08~0.15	2.0~5.0	6.3~12.5
Roughing	250~280	300~1,200	0.08~0.15	2.0~5.0	6.3~12.5
Finishing	190~210	200~900	0.08~0.15	0.1~0.5	0.8
Finishing	220~240	200~700	0.08~0.15	0.1~0.5	0.8
Finishing	250~280	200~500	0.08~0.15	0.1~0.5	0.8

SNCN .. ENTN

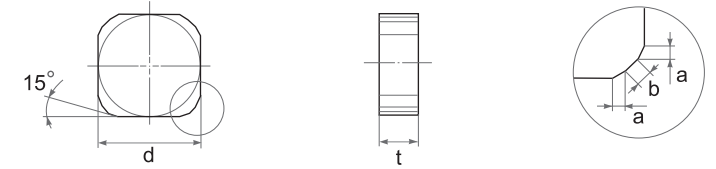

Type		Dimensions (mm)				ST100	ST300	ST500	ST900	TC300	TM300	SD200	SZ200	SZ300	SN26	SN300	SN400	SN500	SN600	SN800	SNT1000	NC400	SW400	SW800
ISO	ASA	d	t	a	b																			
SNCN 1204 ENTN	SNCN 43 ENTN	12.70	4.76	1.40	1.00										●	●	●							

SNGN

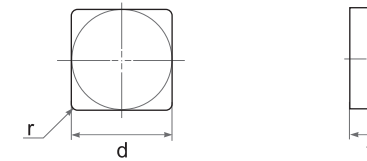

Type		Dimensions (mm)			ST100	ST300	ST500	ST900	TC300	TM300	SD200	SZ200	SZ300	SN26	SN300	SN400	SN500	SN600	SN800	SNT1000	NC400	SW400	SW800
ISO	ASA	d	t	r																			
SNGN 120412	SNGN 433	12.70	4.76	1.2		●										●							
SNGN 120416	SNGN 434	12.70	4.76	1.6		●										●							

FACE MILLING CUTTER

SFSX .. 00 .. EC

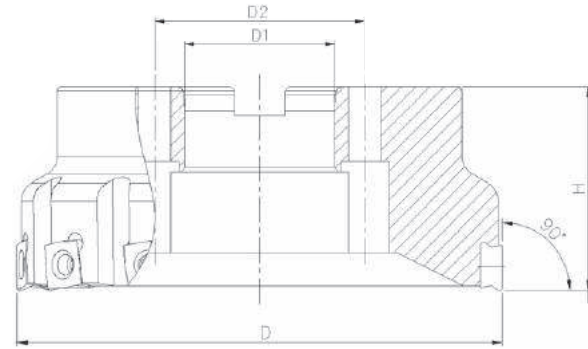

Type	Dimensions (mm)				⚙️	Insert
	D	D ₁	D ₂	H		
SFSX 050-05-00-A5EC	50	22		40	5	SPHX1205 NR
SFSX 050-05-00-A5ECA	50.8	19.05		44.5	5	
SFSX 063-07-00-A5EC	63	22	-	40	7	
SFSX 063-07-00-A5ECA	63.5	19.05		44.5	7	
SFSX 080-08-00-A5EC	80	27	-	50	8	
SFSX 080-08-00-A5ECA	76.2	25.4		44.5	8	
SFSX 100-12-00-A5EC	100	32	-	50	12	
SFSX 100-12-00-A5ECA	101.6	38.1		60.5	12	
SFSX 125-15-00-A5EC	125	40	-	63	15	
SFSX 125-15-00-A5ECA	127.0	38.1		60.5	15	
SFSX 160-18-00-A5EC	160	40	66.7	63	18	
SFSX 160-18-00-A5ECA	152.4	50.8		60.5	18	
SFSX 200-24-00-A5EC	200	60		63	24	
SFSX 200-24-00-A5ECA	203.2	63.5		60.5	24	
SFSX 250-30-00-A5EC	250	60		63	30	
SFSX 250-30-00-A5ECA	254.0	63.5		60.5	30	
SFSX 080-06-00-AT6EC	80	27	-	50	6	SPHX15T6 NR
SFSX 080-06-00-AT6ECA	76.2	25.4		44.5	6	
SFSX 100-08-00-AT6EC	100	32	-	50	8	
SFSX 100-08-00-AT6ECA	101.6	31.75		44.5	8	
SFSX 125-10-00-AT6EC	125	40	-	63	10	
SFSX 125-10-00-AT6ECA	127	38.1		60.5	10	
SFSX 160-14-00-AT6EC	160	40	66.7	63	14	
SFSX 160-14-00-AT6ECA	152.4	50.8		60.5	14	

SPHX

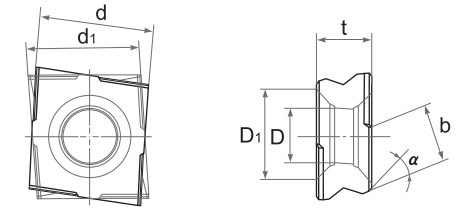

Type	Dimensions (mm)																											
	ISO	d	t	a	b	t	a	b	ST100	ST300	ST500	ST900	TC300	TM300	SD200	SZ200	SZ300	SN26	SN300	SN400	SN500	SN600	SN800	SNT1000	NC400	SW400	SW800	
SPHX 1205NR 480T	11.67	11.33	5.50	5.10	8.41	45	8.0													●	●							
SPHX 1205NL 480T	11.67	11.33	5.50	5.10	8.41	45	8.0																					
SPHX 15T6NR 880T	14.58	14.33	6.60	6.10	10.18	45	8.80													●	●							

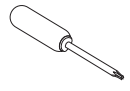
Dimensions (mm)	Spare parts	
	Screw	Wrench
D		
50 - 250 (SPHX1205 NR)	C94010	T15
80 - 160 (SPHX15T6 NR)	C95012	T20

Recommended Cutting Conditions

Process	Cutting Speed V _c (m/min)	Feed f _z (mm/z)	Depth a _p (mm) max
Gray Cast Irons	500 ~1,400	0.15 ~0.25	~5.0
Ductile Cast Irons	450 ~900	0.10 ~0.20	~3.0

FACE MILLING CUTTER

SFSX .. 70 .. EC

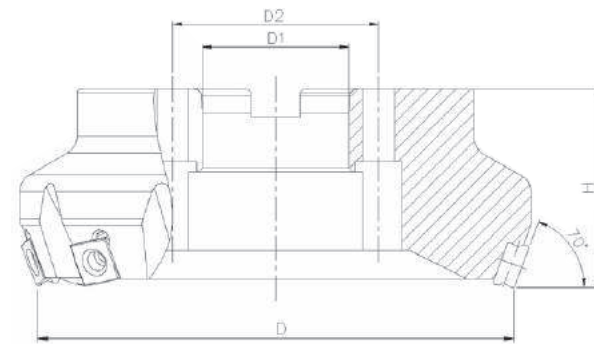

Type	Dimensions (mm)				⚙️	Insert
	D	D ₁	D ₂	H		
SFSX 050-05-70-A5EC	50	22		40	5	SPHX1205 ER
SFSX 050-05-70-A5ECA	50.8	19.05		44.5	5	
SFSX 063-07-70-A5EC	63	22	-	40	7	
SFSX 063-07-70-A5ECA	63.5	19.05		44.5	7	
SFSX 080-08-70-A5EC	80	27	-	50	8	
SFSX 080-08-70-A5ECA	76.2	25.4		44.5	8	
SFSX 100-12-70-A5EC	100	32	-	50	12	
SFSX 100-12-70-A5ECA	101.6	38.1		60.5	12	
SFSX 125-15-70-A5EC	125	40	-	63	15	
SFSX 125-15-70-A5ECA	127.0	38.1		60.5	15	
SFSX 160-18-70-A5EC	160	40	66.7	63	18	
SFSX 160-18-70-A5ECA	152.4	50.8	101.6	60.5	18	
SFSX 200-24-70-A5EC	200	60	101.6	63	24	
SFSX 200-24-70-A5ECA	203.2	63.5	101.6	60.5	24	
SFSX 250-30-70-A5EC	250	60	101.6	63	30	
SFSX 250-30-70-A5ECA	254.0	63.5	101.6	60.5	30	
SFSX 080-07-70-AT6EC	80	27	-	50	7	SPHX15T6 ER
SFSX 080-07-70-AT6ECA	76.2	25.4		44.5	7	
SFSX 100-09-70-AT6EC	100	32	-	50	9	
SFSX 100-09-70-AT6ECA	101.6	31.75		44.5	9	
SFSX 125-12-70-AT6EC	125	40	-	63	12	
SFSX 125-12-70-AT6ECA	127	38.1		60.5	12	
SFSX 160-16-70-AT6EC	160	40	66.7	63	16	
SFSX 160-16-70-AT6ECA	152.4	50.8	-	60.5	16	

SPHX

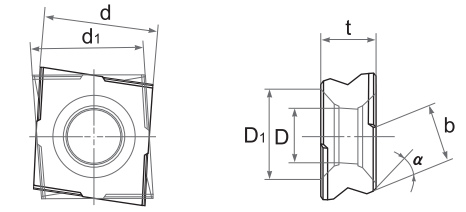

Type	Dimensions (mm)							Material																				
	ISO	d	d ₁	t	D	D ₁	α	b	ST100	ST300	ST500	ST900	TC300	TM300	SD200	SZ200	SZ300	SN26	SN300	SN400	SN500	SN600	SN800	SNT1000	NC400	SW400	SW800	
SPHX 1205ER 855T	12.09	11.33	5.50	5.10	8.41	35	5.50													●	●							
SPHX 1205EL 855T	12.09	11.33	5.50	5.10	8.41	35	5.50													●								
SPHX 15T6ER 865T	15.50	14.33	6.60	6.10	10.18	35	6.50													●	●							

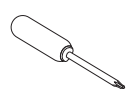
Dimensions (mm)	Spare parts	
	Screw	Wrench
D		
50 - 250 (SPHX1205 ER)	C94010	T15
80 - 160 (SPHX15T6 ER)	C95012	T20

Recommended Cutting Conditions

Process	Cutting Speed V _c (m/min)	Feed f _z (mm/z)	Depth a _p (mm) max
Gray Cast Irons	500~1,400	0.15~0.25	~5.0
Ductile Cast Irons	450~900	0.10~0.20	~3.0

FACE MILLING CUTTER



SFSP .. OT

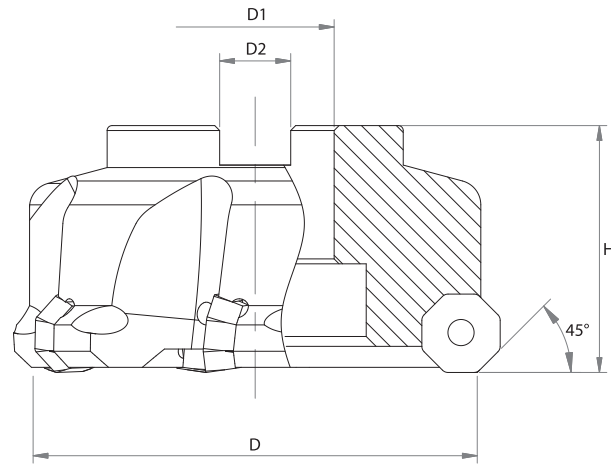

Axial rake angle : +3°
Radial rake angle : +7°



Type	Dimensions (mm)				Insert
	D	D ₁	D ₂	H	
SFSP 063-05-45-A4 OT	63	22	10.40	40	5
SFSP 080-06-45-A4 OT	80	27	12.40	50	6
SFSP 100-07-45-A4 OT	100	32	14.40	50	7

Dimensions (mm)	Spare parts	
	Screw	Wrench
63 - 100	 SWS 21480072	 T20

OEGB

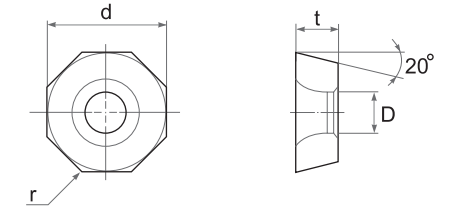

Type	Dimensions (mm)				ST100	ST300	ST500	ST900	TC300	TM300	SD200	SZ200	SZ300	SN26	SN300	SN400	SN500	SN600	SN800	SNT1000	NC400	SW400	SW800
	ISO	d	t	D																			
OEGB 070408	15.87	4.76	5.18	0.8												●							
OEGB 070416	15.87	4.76	5.18	1.6											●	●							

FACE MILLING CUTTER

SFKN .. HX



D : 80~200

Axial rake angle : -6°



Radial rake angle : -7°

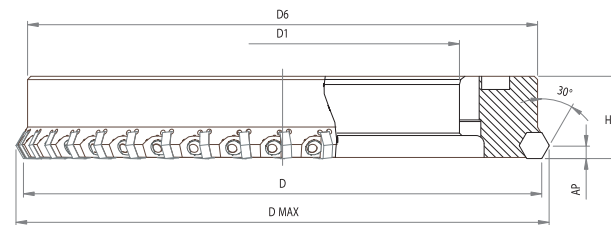
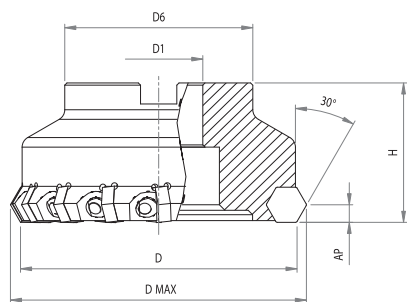

D : 250~315



Type	Dimensions (mm)					Z	AP max	Insert
	D	D(max)	D ₁	D ₆	H			
SFKN 080-08-30 N5HXA	80	88.7	25.4	52	50	8	8	HNEN 090520 HNEN 090530 HNEN 090508 ANSN
SFKN 080-08-30 N5HX	80	88.7	27	58	50	8	8	
SFKN 100-10-30 N5HXA	100	108.7	31.75	60	50	10	8	
SFKN 100-10-30 N5HX	100	108.7	32	60	50	10	8	
SFKN 125-16-30 N5HXA	125	133.7	38.1	80	63	16	8	
SFKN 125-16-30 N5HX	125	133.7	40	85	63	16	8	
SFKN 160-20-30 N5HXA	160	168.7	50.8	99	63	20	8	
SFKN 160-20-30 N5HX	160	168.7	40	85	63	20	8	
SFKN 200-26-30 N5HXA	200	208.7	47.625	128.57	63	26	8	
SFKN 200-26-30 N5HX	200	208.7	60	140	63	26	8	
SFKN 250-30-30 N5HXA	250	258.7	160.02	-	50	30	8	
SFKN 315-40-30 N5HXA	315	323.7	215.02	-	50	40	8	

Dimensions (mm)	Spare parts		
	Wedge	Wedge Screw	Wrench
80 - 315	 DT-SW16	 WS6	 LW3

HNEN

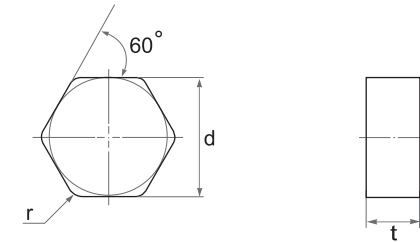

Type	Dimensions (mm)			ST100	ST300	ST500	ST900	TC300	TM300	SD200	SZ200	SZ300	SN26	SN300	SN400	SN500	SN600	SN800	SN1000	NC400	SW400	SW800	
	ISO	d	t																				r
HNEN 090520		16.20	5.56	2.0										●	●								
HNEN 090530		16.20	5.56	3.0										●	●								
HNEN 090508 ANSN		15.87	5.64	0.8										●	●			●	●				

FACE MILLING CUTTER

SFKP .. MF

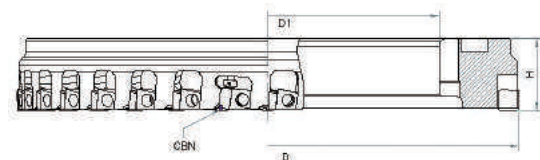

Type	Dimensions (mm)					Insert
	D	D ₁	H	Ceramic	CBN	
SFKP 250-20-00 N4MF	250	160.02	50	18	2	SPCN120412(Ceramic)+CBN(Wiper)
SFKP 315-32-00 N4MF	315	215.02	50	28	4	SPCN120412(Ceramic)+CBN(Wiper)

Dimensions (mm)	Spare parts			
	Wedge	Adjust Screw	Wedge Screw	Wrench
D				
250 - 315	DT-DW01	AJM 5F	WS8	LW4

Recommended Cutting Condition for Gray Cast Iron

Process	Hardness (HB)	Cutting Speed Vc(m/min)	Feed fz(mm/z)	Depth ap(mm)
Finishing	190~210	200~800	0.08~0.15	0.1~0.5
Finishing	220~240	200~600	0.08~0.15	0.1~0.5
Finishing	250~280	200~400	0.08~0.15	0.1~0.5

Recommended Cutting Condition for Ductile Cast Iron

Process	Tensile Strength	Cutting Speed Vc(m/min)	Feed fz(mm/z)	Depth ap(mm)
Finishing	400~500	300~600	0.08~0.15	0.1~0.5
Finishing	500~700	200~500	0.08~0.15	0.1~0.5

SPCN .. T

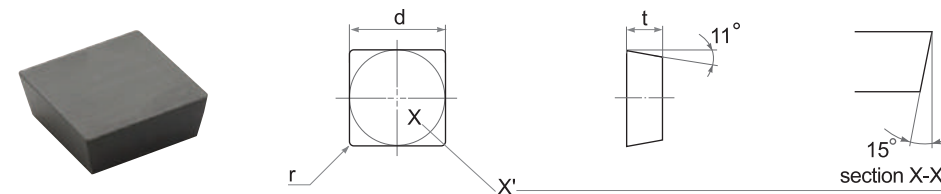

Type		Dimensions (mm)			ST100	ST300	ST500	ST900	TC300	TM300	SD200	SZ200	SZ300	SN26	SN300	SN400	SN500	SN600	SN800	SNT1000	NC400	SW400	SW600	
ISO	ASA	d	t	r																				
SPCN 120412 T15	SPCN 433 T15	12.70	4.76	1.2												●								

SPCN .. T

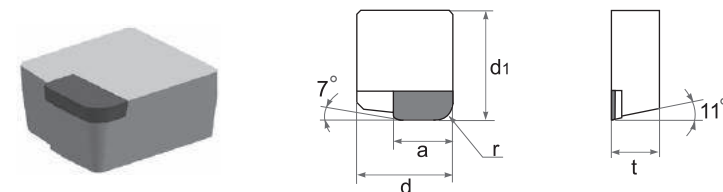

Type		Dimensions (mm)					PCBN	
ISO	ASA	d	D ₁	t	a	r	SBN1000	SBN2000
SPC 1206 ZZR2X	SPC 44 ZZR2X	12.70	14.50	6.35	7.80	2.0	●	

FACE MILLING CUTTER

SFMS (MULTI-STEP) .. LRF



Axial rake angle : +5°
Radial rake angle : +6°

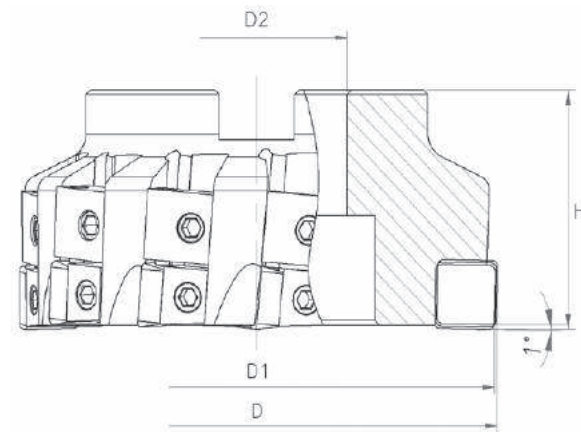

Type	Dimensions (mm)				Insert per set	⚙️	Insert
	D	D ₁	D ₂	H			
SFMS 80-09-P4N.LRF	76.20	75.20	25.40	47.60	3	9	SPCN 1204 □□T15
SFMS 100-12-P4N.LRF	101.60	100.60	38.10	47.60	3	12	
SFMS 125-15-P4N.LRF	127.00	126.00	38.10	47.60	3	15	
SFMS 160-18-P4N.LRF	152.40	151.40	50.80	47.60	3	18	

Dimensions (mm) D	Spare parts				
	Wedge	Wedge Screw	ADJ Wedge	ADJ Wedge Screw	Wrench
80 - 160	DT-SW14	WS6	DT-SW15	WS6	LW3

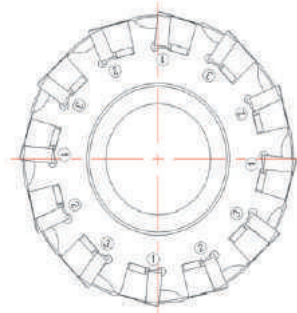

Recommended Cutting Condition for Gray Cast Iron

Process	Hardness (HB)	Cutting Speed Vc(m/min)	Feed fz(mm/z)	Depth ap(mm)	Surface Quality Ra(μm)
Light Rough & Finish	190~310	240~1,200	0.08~0.60	2.0~3.80	6.3~12.5

SPCN .. T

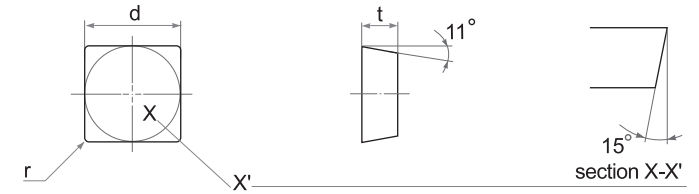
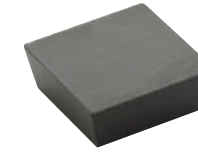



Type		Dimensions (mm)			ST100	ST300	ST500	ST900	TC300	TM300	SD200	SZ200	SZ300	SN26	SN300	SN400	SN500	SN600	SN800	SNT1000	NC400	SW400	SW800	
ISO	ASA	d	t	r																				
SPCN 120412 T15	SPCN 433 T15	12.70	4.76	1.2												●								
SPCN 120416 T15	SPCN 434 T15	12.70	4.76	1.6												●								

FACE MILLING CUTTER

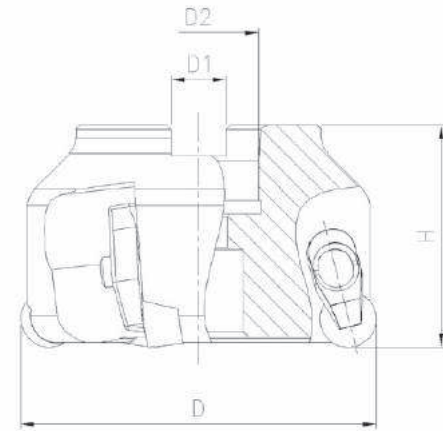
SFCN .. 00 .. R

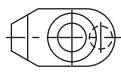

Type	Dimensions (mm)				⚙️	Insert
	D	D ₁	D ₂	H		
SFCN 050-04-00 R4	50	10.4	22	50	4	RNGN 120400
SFCN 050-04-00 R4A	50.8	7.9	19.05	50	4	
SFCN 063-04-00 R4	63	10.4	22	50	4	
SFCN 063-04-00 R4A	63.5	7.9	19.05	50	4	
SFCN 080-05-00 R4	80	12.4	27	50	5	
SFCN 080-05-00 R4A	76.2	9.5	25.4	50	5	
SFCN 100-06-00 R4	100	14.4	32	50	6	RNGN 120700
SFCN 100-06-00 R4A	101.6	12.7	31.75	50	6	
SFCN 050-04-00 R7	50	10.4	22	50	4	
SFCN 050-04-00 R7A	50.8	7.9	19.05	50	4	
SFCN 063-04-00 R7	63	10.4	22	50	4	
SFCN 063-04-00 R7A	63.5	7.9	19.05	50	4	
SFCN 080-05-00 R7	80	12.4	27	50	5	
SFCN 080-05-00 R7A	76.2	9.5	25.4	50	5	
SFCN 100-06-00 R7	100	14.4	32	50	6	
SFCN 100-06-00 R7A	101.6	12.7	31.75	50	6	

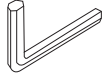
Dimensions (mm)	Spare parts			
	Clamp	Clamp Screw	Spring	Wrench
50 - 100	 AMS6T	 AOB-6S	 SP5	 LW3

RNGN

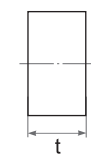
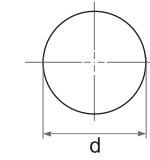

Type		Dimensions (mm)		Grade			
ISO	ASA	d	t	SW400	SW800	SN800	SN1000
RNGN 120400	RNGN 43	12.7	4.76	●	●	●	●
RNGN 120700	RNGN 45	12.7	7.94	●	●	●	●

FACE MILLING CUTTER

SFCP .. 00 .. R

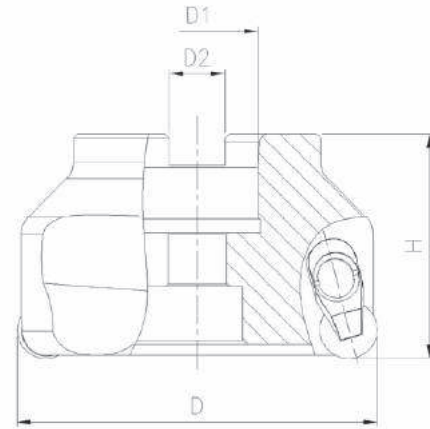

Type	Dimensions (mm)				⚙️	Insert
	D	D ₁	D ₂	H		
SFCP 050-04-00 R4	50	10.4	22	50	4	RPGN 120400
SFCP 050-04-00 R4A	50.8	7.9	19.05	50	4	
SFCP 063-04-00 R4	63	10.4	22	50	4	
SFCP 063-04-00 R4A	63.5	7.9	19.05	50	4	
SFCP 080-05-00 R4	80	12.4	27	50	5	
SFCP 080-05-00 R4A	76.2	9.5	25.4	50	5	
SFCP 100-06-00 R4	100	14.4	32	50	6	
SFCP 100-06-00 R4A	101.6	12.7	31.75	50	6	

Dimensions (mm)	Spare parts			
	Clamp	Clamp Screw	Spring	Wrench
50 - 100	AMS6T	A0B-6S	SP5	LW3

CERAMIC

CERMET

PCBN / PCD

TOOL HOLDER

MILLING CUTTER

RPGN

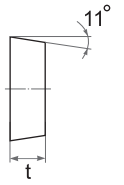
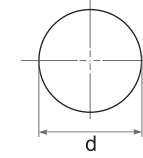
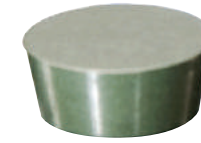

Type		Dimensions (mm)		Grade			
ISO	ASA	d	t	SW400	SW800	SN800	SN1000
RPGN120400	RPGN 43	12.7	4.76		●	●	●

CERAMIC

CERMET

PCBN / PCD

TOOL HOLDER

MILLING CUTTER



FACE MILLING CUTTER

TURNING
&
MILLING

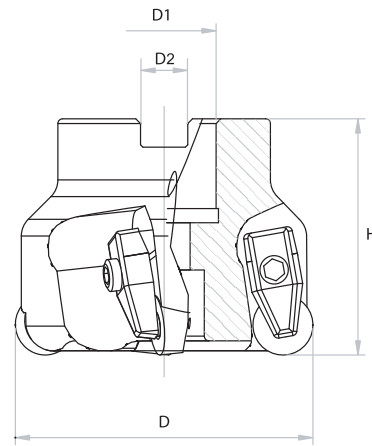
SFXN

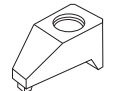

Type	Dimensions (mm)				⚙️	Insert
	D	D ₁	D ₂	H		
SFXN 050-03-00 RX7A	50	19.05	7.9	50	3	RNGX 1207 DP
SFXN 050-03-00 RX7	50	22	10.4	50	3	
SFXN 063-04-00 RX7A	63	19.05	12.7	50	4	
SFXN 063-04-00 RX7	63	22	10.4	50	4	
SFXN 080-05-00 RX7A	80	25.4	9.5	50	5	
SFXN 080-05-00 RX7	80	27	12.4	50	5	
SFXN 100-06-00 RX7A	100	31.75	12.7	50	6	
SFXN 100-06-00 RX7	100	32	14.4	50	6	

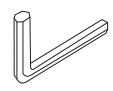
Dimensions (mm)	Spare parts			
	Clamp	Screw	Spring	Wrench
D				
50 - 100	SCL 5M	SLS4	SP4	LW3

Recommended Cutting Conditions

Work - Piece	Hardness (HB)	Cutting Speed V _c (m/min)	Feed f _z (mm/z)	Depth a _p (mm) max
Iron-base, Heat-resistant alloys	135~328	300~900	0.05~0.13	6.35
Cobalt-base, Heat-resistant alloys	150~425	270~1,200	0.05~0.13	6.35
Nickel base, Heat-resistant alloys	140~475	270~1,200	0.05~0.13	6.35
PH Stainless steels	135~450	520~700	0.08~0.10	6.35

CERAMIC

CERMET

PCBN / PCD

TOOL HOLDER

MILLING CUTTER

RNGX .. DP

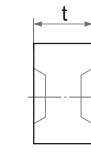
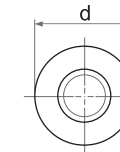

Type		Dimensions (mm)		ST100	ST300	ST500	ST900	TC300	TM300	SD200	SZ200	SZ300	SN26	SN300	SN400	SN500	SN600	SN800	SNT1000	NC400	SW400	SW800	
ISO	ASA	d	t																				
RNGX 1207 DP	RNGX 45 DP	12.70	7.94												●		●	●	●				

TURNING
&
MILLING

CERAMIC

CERMET

PCBN / PCD

TOOL HOLDER



MILLING CUTTER

FACE MILLING CUTTER

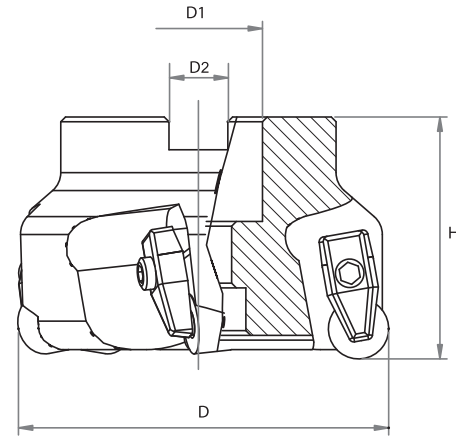
SFXP

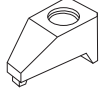

Type	Dimensions (mm)				⚙️	Insert
	D	D ₁	D ₂	H		
SFXP 050-03-00 RP4A	50	19.05	7.9	50	3	RPGX 1204 DP
SFXP 050-03-00 RP4	50	22	10.4	50	3	
SFXP 050-04-00 RP4A	50	19.05	7.9	50	4	
SFXP 050-04-00 RP4	50	22	10.4	50	4	
SFXP 063-04-00 RP4A	63	19.05	7.9	63	4	
SFXP 063-04-00 RP4	63	22	10.4	63	4	
SFXP 080-05-00 RP4A	80	25.4	9.5	50	5	
SFXP 080-05-00 RP4	80	27	12.4	50	5	
SFXP 100-06-00 RP4A	100	31.75	12.7	50	6	
SFXP 100-06-00 RP4	100	32	14.4	50	6	

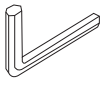
Dimensions (mm)	Spare parts			
	Clamp	Screw	Spring	Wrench
D				
50 - 100	SCL 5M	SLS4	SP4	LW3

Recommended Cutting Conditions

Work - Piece	Hardness (HB)	Cutting Speed Vc(m/min)	Feed fz(mm/z)	Depth Ap(mm) max
Iron-base, Heat-resistant alloys	135~328	300~900	0.05~0.13	6.35
Cobalt-base, Heat-resistant alloys	150~425	270~1,200	0.05~0.13	6.35
Nickel base, Heat-resistant alloys	140~475	270~1,200	0.05~0.13	6.35
PH Stainless steels	135~450	520~700	0.08~0.10	6.35

RPGX .. DP

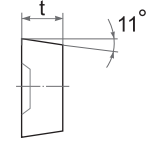
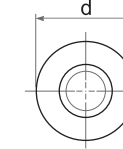

Type		Dimensions (mm)		ST100	ST300	ST500	ST900	TC300	TM300	SD200	SZ200	SZ300	SN26	SN300	SN400	SN500	SN600	SN800	SNT1000	NC400	SW400	SW800	
ISO	ASA	d	t																				
RPGX 1204 DP	RPGX 43 DP	12.70	4.76												●			●	●				

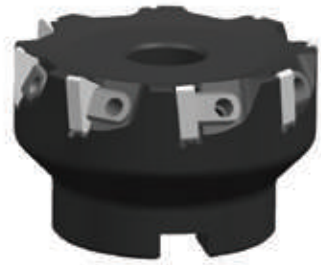

FACE MILLING CUTTER

SFKN .. 90

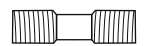

Axial rake angle $Y_a = -6^\circ$
Radial rake angle $Y_r = -10^\circ$
Mounting According to DIN 8030

Type	Dimensions (mm)				Z	Insert
	D	D ₁	L	L ₁		
SFKN 050-05-90 T4	50	22	10.4	40	5	TNCN 1604 TNGN 1604
SFKN 063-06-90 T4	63	22	10.4	40	6	
SFKN 080-08-90 T4	80	27	12.4	50	8	
SFKN 100-10-90 T4	100	32	14.4	50	10	
SFKN 125-12-90 T4	125	40	16.4	63	12	

Dimensions (mm) D	Spare parts		
	Wedge	Wedge Screw	Wrench
50~125	 SSW10	 WS6	 LW3

Recommended Cutting Condition for Gray Cast Iron



Work - piece	Cutting Speed Vc [m/min]	Feed Fz [mm/z]	Depth Ap [mm] mx	Surface Quality Ra(μm)
Gray Cast Iron	600~1000	0.16~0.3	0.5~1.0	6.3~12.5

FACE MILLING CUTTER

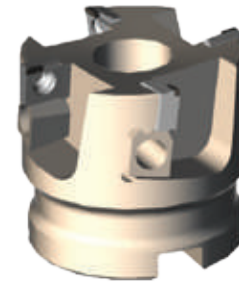
SMCD .. 90

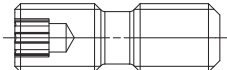
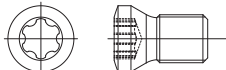

Type	Dimensions (mm)				Z	Insert
	D	D ₁	d ₂	L ₁		
SMCD 050-05-90	50	22	10	45	4	SNEW 09T3WF

Dimensions (mm) D	Spare parts		
	Screw	Wrench	Wedge
50	 DS0618-T15	 KH04008	 WD081009-M6

SNEW





Type	Dimensions (mm)			SBN 1000	SBN 2000	SBN 3000	SBN 4000
	d	t	R				
SNEW 09T308	9.52	3.97	0.8				

FACE MILLING CUTTER

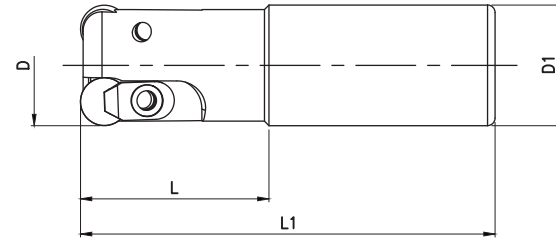
SECP

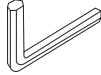

Type	Dimensions (mm)				Z	Insert
	D	D ₁	L	L ₁		
SECP 016-02-2575 RP2	16	16	25	75	2	RPGN0602
SECP 020-02-3085 RP3	20	20	30	85	2	RPGN0903
SECP 020-03-3085 RP2	20	20	30	85	3	RPGN0602
SECP 025-03-4095 RP3	25	25	40	95	3	RPGN0903
SECP 032-03-50110 RP4	32	32	50	110	3	RPGN1204
SECP 040-04-50110 RP4	40	32	50	110	4	RPGN1204
SECP 016-02-2575 RP2A	16	15.88	25	75	2	RPGN0602
SECP 020-03-3085 RP3A	20	19.05	30	85	2	RPGN0903
SECP 020-03-3085 RP2A	20	19.05	30	85	3	RPGN0602
SECP-025-03-4095 RP3A	25	25.40	40	95	3	RPGN0903
SECP 032-03-50110 RP4A	32	31.75	50	110	3	RPGN1204
SECP 040-04-50110 RP4A	40	38.10	50	110	4	RPGN1204

Dimensions (mm)	Spare parts			
	Clamp	Clamp Screw	Spring	Wrench
				
16~40	AMS-3 AMS-4 AMS-5T	AOB3S AOB4S AOB5S	SP3 SP4 SP5	LW2 LW2.5 LW3

Work - Piece	Hardness (HB)	Cutting Speed V _c (m/min)	Feed f _z (mm/z)	Depth A _p (mm) max
Iron Based Heat Resistant Alloys	135~328	800~1,400	0.05~0.15	6.35
Nickel Based Resistant Alloys	150~425	1,400~2,000	0.05~0.15	6.35
Cobalt Based Resistant Alloys	140~475	1,400~2,000	0.05~0.15	6.35

FACE MILLING CUTTER

BALL ENDMILL

SEXP

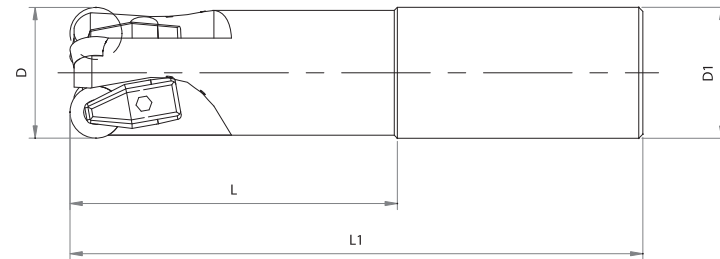

Type	Dimensions (mm)				⚙️	Insert
	D	D ₁	L	L ₁		
SEXP 032-02-80140 X4	32	32	80	140	2	RPGX 1204 DP
SEXP 032-03-40100 X4A	32	31.75	40	100	3	
SEXP 032-03-40100 X4	32	32	40	100	3	
SEXP 032-03-80140 X4A	32	31.75	80	140	3	
SEXP 032-03-80140 X4	32	32	80	140	3	
SEXP 038-03-50100 X4A	38	38.1	50	100	3	
SEXP 038-03-50100 X4	38	32	50	100	3	
SEXP 038-03-90140 X4A	38	38.1	90	140	3	
SEXP 038-03-90140 X4	38	32	90	140	3	

Dimensions (mm)	Spare parts			
	Clamp	Screw	Spring	Wrench
32 - 38	SCL 5M	SLS4	SP4	LW3

Recommended Cutting Conditions

Work - Piece	Hardness (HB)	Cutting Speed V _c (m/min)	Feed f _z (mm/z)	Depth a _p (mm) max
Iron-base, Heat-resistant alloys	135~328	300~900	0.05~0.13	6.35
Cobalt-base, Heat-resistant alloys	150~425	270~1,200	0.05~0.13	6.35
Nickel base, Heat-resistant alloys	140~475	270~1,200	0.05~0.13	6.35
PH Stainless steels	135~450	520~700	0.08~0.10	6.35

RPGX .. DP

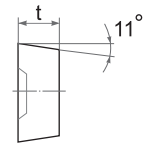
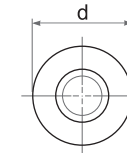

Type		Dimensions (mm)		ST100	ST300	ST500	ST900	TC300	TM300	SD200	SZ200	SZ300	SN26	SN300	SN400	SN500	SN600	SN800	SNT1000	NC400	SW400	SW800	
ISO	ASA	d	t																				
RPGX 1204 DP	RPGX 43 DP	12.70	4.76												●			●	●				

CHAMFER CUTTER

CSC

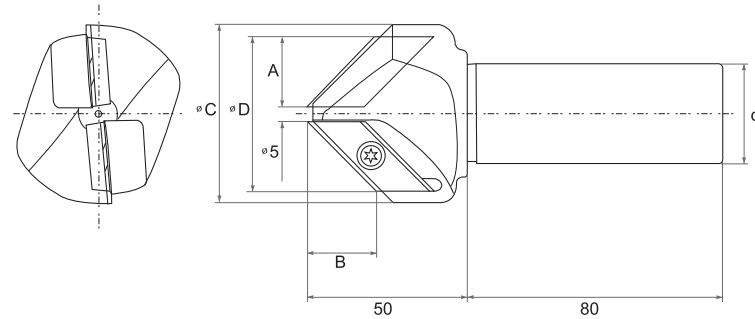

Type	Dimensions (mm)						Insert	Spare parts		
	θ	A	B	$\varnothing C$	$\varnothing D$	d		Screw	Wrench	
CSC 0503 1R-30	30°	15.5	20.5	40	36.0	32.0	1	XCET 310404ER	SDT050	T-20
CSC 0503 1R-30-A	30°	15.5	20.5	40	36.0	25.4	1			
CSC 0503 1R-30-A-2F	30°	15.5	26.0	47	43.0	25.4	2			
CSC 0503 1R-41-A	41°	20.5	20.5	56	46.0	25.4	2			
CSC 0503 1R-45	45°	22.0	20.5	56	46.0	32.0	2			
CSC 0503 1R-45-A	45°	22.0	20.5	56	46.0	25.4	2			
CSC 0503 1R-60	60°	26.5	15.0	72	55.0	32.0	2			
CSC 0503 1R-60-A	60°	26.5	15.0	72	55.0	25.4	2			

Recommended Cutting Conditions

Work piece	Carbon Steel (S55C) Stainless Steel 250HB \geq Cast Iron (FC250)	Alloy Steel (SCM440) 300HB \geq High Alloy Steel (SKD61) 300HB \geq
Feed (mm/tooth)	0.1~0.25	0.1~0.2
rpm	3000(1000 ~7000)	

XCET

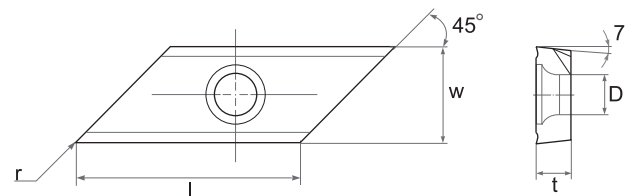

Type	Dimensions (mm)					Grade		
	l	w	t	D	r	TX515	TX520	SCW200
XCET 310404 ER	22.00	12.70	4.50	5.60	0.4		●	●
XCET 310408 ER	22.00	12.70	4.50	5.60	0.8		●	

*SCW200 is a coated carbide grade for P20 range machining.

TECHNICAL DATA

30° Chamfer

Hole Dia $\varnothing d$	Dimensions (mm)							
	0.5	1	1.5	2	2.5	3	3.5	4
5	0.8	1.3	1.8	2.3	2.8			
6	1.7	2.2	2.7	3.2	3.7			
6.8	2.4	2.9	3.4	3.9	4.4			
8	3.4	3.9	4.4	4.9	5.4			
8.5	3.8	4.3	4.8	5.3	5.8			
10	5.1	5.6	6.1	6.6	7.1	7.6	8.1	8.6
10.2	5.3	5.8	6.3	6.8	7.3	7.8	8.3	8.8
12	6.9	7.4	7.9	8.4	8.9	9.4	9.9	10.4
16	10.3	10.8	11.3	11.8	12.3	12.8	13.3	13.8
17.5	11.6	12.1	12.6	13.1	13.6	14.1	14.6	15.1
20	13.7	14.2	14.7	15.2	15.7	16.2	16.7	17.2
21	14.6	15.1	15.6	16.1	16.6	17.1	17.6	18.1
24	17.2	17.7	18.2	18.7	19.2	19.7	20.2	20.7
30	22.4	22.9	23.4	23.9	24.4	24.9	25.4	
33	24.9	25.4						

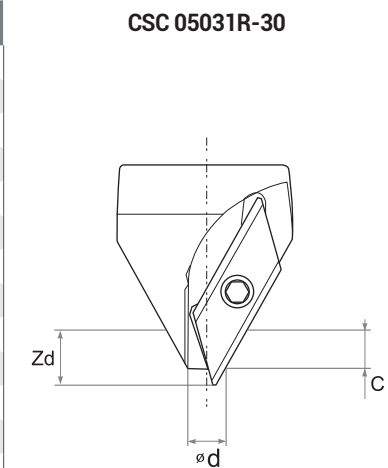

45° Chamfer

Hole Dia $\varnothing d$	Dimensions (mm)						
	0.5	1	1.5	2	3	4	5
5	0.7	1.2	1.7	2.2	3.2		
6	1.2	1.7	2.2	2.7	3.7		
6.8	1.6	2.1	2.6	3.1	4.1		
8	2.2	2.7	3.2	3.7	4.7		
8.5	2.4	2.9	3.4	3.9	4.9		
10	3.2	3.7	4.2	4.7	5.7	6.7	7.7
10.2	3.3	3.8	4.3	4.8	5.8	6.8	7.8
12	4.2	4.7	5.2	5.7	6.7	7.7	8.7
14	5.2	5.7	6.2	6.7	7.7	8.7	9.7
16	6.2	6.7	7.2	7.7	8.7	9.7	10.7
17.5	6.9	7.4	7.9	8.4	9.4	10.4	11.4
20	8.2	8.7	9.2	9.7	10.7	11.7	12.7
21	8.7	9.2	9.7	10.2	11.2	12.2	13.2
24	10.2	10.7	11.2	11.7	12.7	13.7	14.7
30	13.2	13.7	14.2	14.7	15.7	16.7	17.7
33	14.7	15.2	15.7	16.2	17.2	18.2	19.2
36	16.2	16.7	17.2	17.7	18.7	19.7	
42	19.2	19.7	20.2				

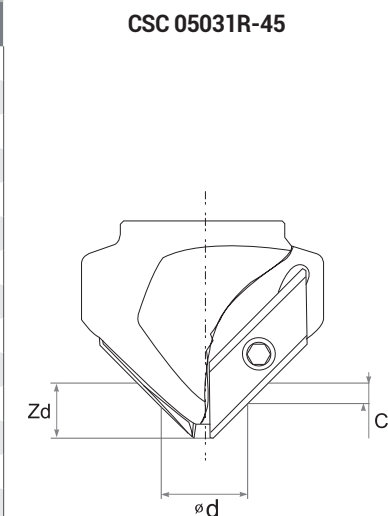

CHAMFER CUTTER

TECHNICAL DATA

60° Chamfer

Hole Dia Ød	Dimensions (mm)						
	0.5	1	1.5	2	2.5	3	3.5
5	0.6	1.1	1.6	2.1			
6	0.9	1.4	1.9	2.4			
6.8	1.1	1.6	2.1	2.6			
8	1.4	1.9	2.4	2.9			
8.5	1.6	2.1	2.6	3.1			
10	2.0	2.5	3.0	3.5	4.0	4.5	5.0
10.2	2.1	2.6	3.1	3.6	4.1	4.6	5.1
12	2.6	3.1	3.6	4.1	4.6	5.1	5.6
16	3.7	4.2	4.7	5.2	5.7	6.2	6.7
17.5	4.2	4.7	5.2	5.7	6.2	6.7	7.2
20	4.9	5.4	5.9	6.4	6.9	7.4	7.9
21	5.2	5.7	6.2	6.7	7.2	7.7	8.2
24	6.1	6.6	7.1	7.6	8.1	8.6	9.1
30	7.8	8.3	8.8	9.3	9.8	10.3	10.8
33	8.7	9.2	9.7	10.2	10.7	11.2	11.7
36	9.5	10.0	10.5	11.0	11.5	12.0	12.5
38	10.1	10.6	11.1	11.6	12.1	12.6	13.1
42	11.2	11.7	12.2	12.7	13.2	13.7	14.2
46	12.4	12.9	13.4	13.9	14.4		
48	13.0	13.5	14.0	14.5			
52	14.1						

CSC 05031R-60

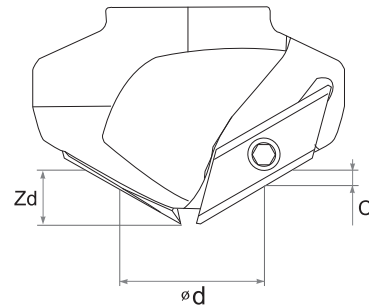

ALUMINUM CUTTER

HPA - I

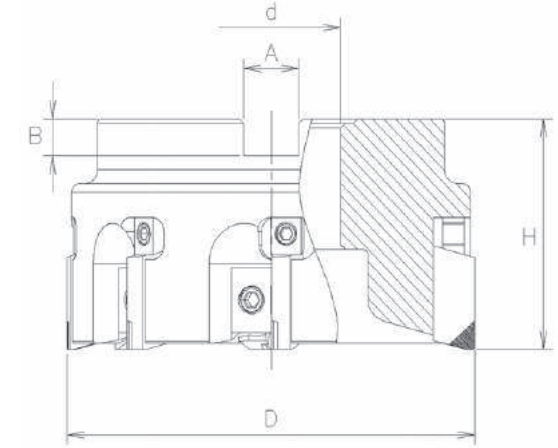

Type	Dimensions (mm)					Z	Weight (kg)	Insert	Arbor
	ØD	Ød	A	B	H				
HPA 025R-I09	63	22	10	6	50	6	0.5	HPA-I09	FMA 22
HPA 03R-I09	80	25.4	9.5	6	50	8	0.7		FMA 25.4
HPA 04R-I09	100	31.75	12.7	8	63	10	1.4		FMA 31.75
HPA 05R-I09	125	38.1	15.9	10	63	12	1.8		FMA 38.1
HPA 06R-I09	160	50.8	19.05	11	63	14	2.4		FMA 50.8
HPA 08R-I09	200	47.625	25.4	14	63	16	3.5		FMA 47.625
HPA 10R-I09	250	47.625	25.4	14	63	18	4.8		FMA 47.625

COMPONENT

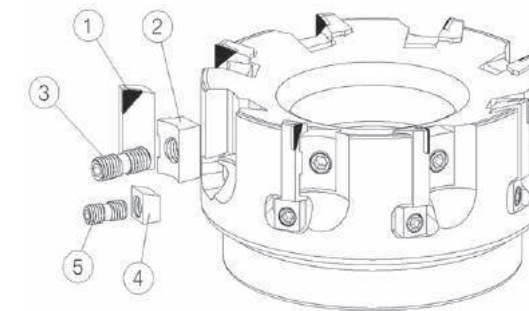

Spare parts				
① Insert	② Wedge	③ Wedge Screw	④ Adjust Wedge	⑤ Adjust Wedge Screw
HPA-I09	DT-ST01	WS6-16	DT-ST02	WS5-11

ALUMINUM CUTTER

HPA - H

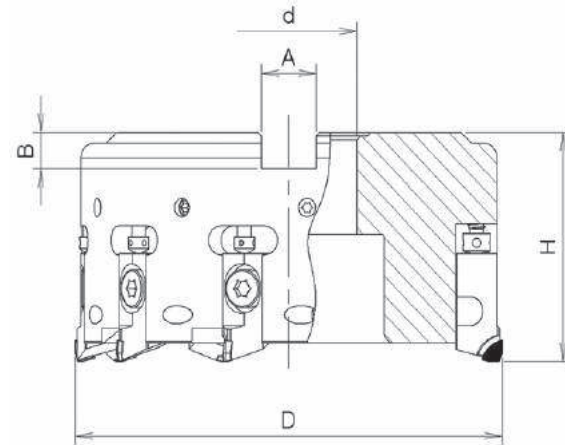

Type	Dimensions (mm)					Z	Weight (kg)	Insert	Arbor
	ØD	Ød	A	B	H				
HPA 02R-H10	50	16	8	6.2	50	4	0.4	ROUGH HPA 10CA-R WIPER HPA 10CA-W	FMA 16
HPA 025R-H10	63	22	10	6	50	4	0.5		FMA 22
HPA 03R-H10	80	25.4	9.5	6	50	6	0.7		FMA 25.4
HPA 04R-H10	100	31.75	12.7	8	50	7	2.2		FMA 31.75
HPA 05R-H10	125	38.1	15.9	10	63	10	1.4		FMA 38.1
HPA 06R-H10	160	50.8	19.05	11	63	12	2.5		FMA 50.8
HPA 08R-H10	200	47.625	25.4	14	63	14	3.5		FMA 47.625
HPA 10R-H10	250	47.625	25.4	14	63	18	4.9		FMA 47.625

COMPONENT

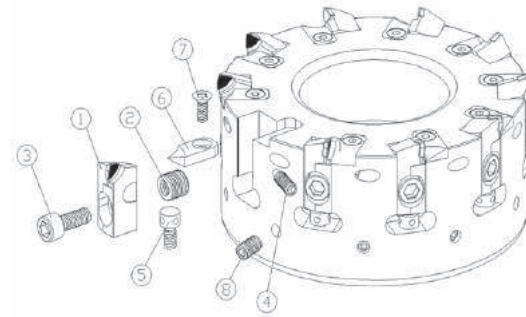

Spare parts				
① Cartridge	① Cartridge	② Double Screw	③ Clamp Screw	④ Side Clamp Screw
HPA 10CA-R	HPA 10CA-W	H108	M6x15	M6x16
⑤ Adjust Screw	⑥ Chip Cover	⑦ Chip Cover Screw	⑧ Balancing Screw	
AJM 5F	HC-R/L	M4x10	M6x10	

ALUMINUM CUTTER

HPA - M

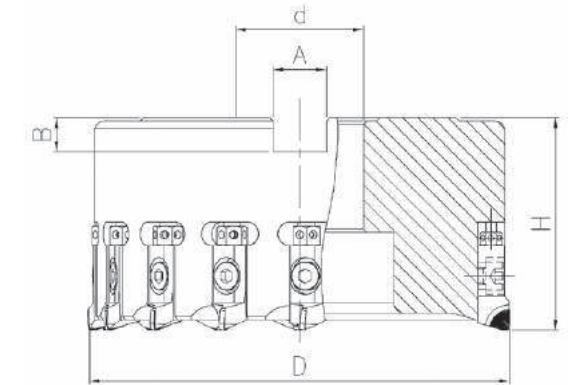

Type	Dimensions (mm)					Z	Weight (kg)	Insert	Arbor
	ØD	Ød	A	B	H				
HPA 03R-M10	80	25.4	9.5	6	50	10	0.8	ROUGH HPA 08CA-R WIPER HPA 08CA-W	FMA 25.4
HPA 04R-M10	100	31.75	12.7	8	50	12	1.2		FMA 31.75
HPA 05R-M10	125	38.1	15.9	10	63	14	2.2		FMA 38.1
HPA 06R-M10	160	50.8	19.05	11	63	18	2.8		FMA 50.8
HPA 08R-M10	200	47.625	25.4	14	63	24	4.5		FMA 47.625
HPA 10R-M10	250	47.625	25.4	14	63	30	7		FMA 47.625

COMPONENT

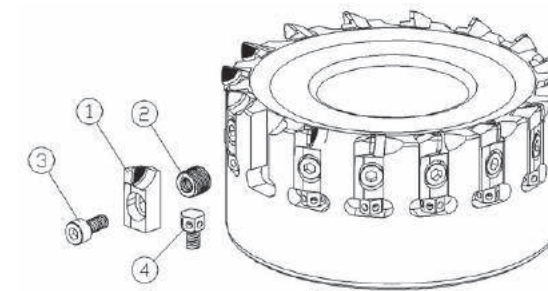

Spare parts				
① Cartridge	① Cartridge	② Double Screw	③ Clamp Screw	④ Adjust Screw
HPA 08CA-R	HPA 08CA-W	H107	M5x12	AJM 5F

ALUMINUM CUTTER

ARBOR

TURNING
&
MILLING

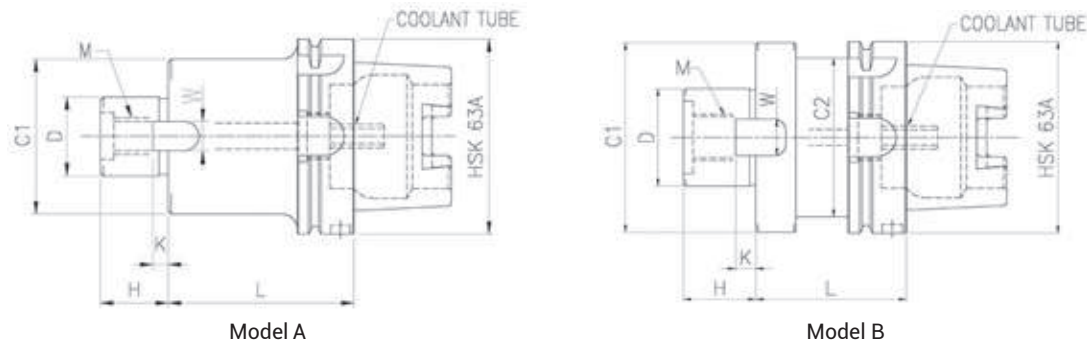

ALUMINUM CUTTER

ARBOR

TURNING
&
MILLING

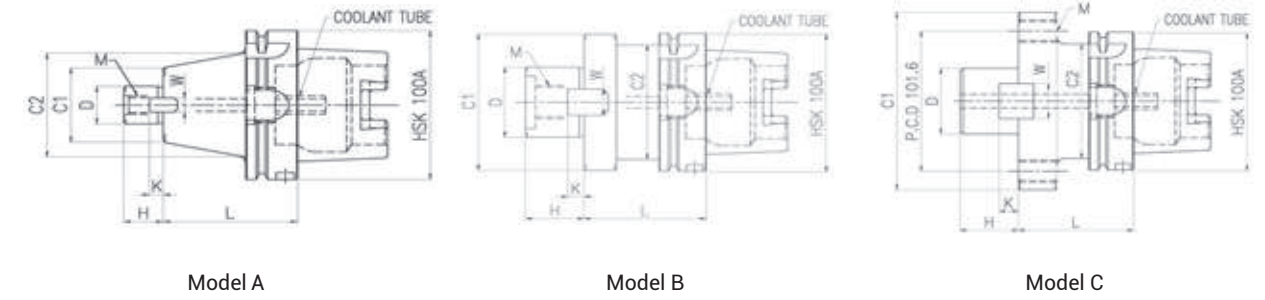

Type	Dimensions (mm)							M	Weight (kg)	Model	Cutter
	D	L	H	C ₁	C ₂	W	K				
HSK 63A-FMA22-50	22	50	19	50	50	9.5	5	M10	1.2	A	HPA 025R
HSK 63A-FMA25.4-60	25.4	60	22	50	50	9.5	5	M12	1.3	A	HPA 03R
HSK 63A-FMA25.4-90	25.4	90	22	50	50	9.5	5	M12	1.9	A	HPA 03R
HSK 63A-FMA25.4-120	25.4	120	22	50	50	9.5	5	M12	2.3	A	HPA 03R
HSK 63A-FMA31.75-60	31.75	60	30	60	53	12.7	7	M16	1.7	B	HPA 04R
HSK 63A-FMA31.75-90	31.75	90	30	60	53	12.7	7	M16	2.5	B	HPA 04R
HSK 63A-FMA31.75-120	31.75	120	30	60	53	12.7	7	M16	3.3	B	HPA 04R
HSK 63A-FMA38.1-60	38.1	60	34	80	53	15.9	9	M20	2.1	B	HPA 05R
HSK 63A-FMA38.1-90	38.1	90	34	80	53	15.9	9	M20	3	B	HPA 05R
HSK 63A-FMA38.1-120	38.1	120	34	80	53	15.9	9	M20	4.4	B	HPA 05R

Type	Dimensions (mm)							M	Weight (kg)	Model	Cutter
	D	L	H	C ₁	C ₂	W	K				
HSK 100A-FMA25.4-75	25.4	75	22	50	70	9.5	5	M12	3.2	A	HPA 03R
HSK 100A-FMA25.4-105	25.4	105	22	50	70	9.5	5	M12	3.9	A	HPA 03R
HSK 100A-FMA25.4-135	25.4	135	22	50	70	9.5	5	M12	4.6	A	HPA 03R
HSK 100A-FMA31.75-75	31.75	75	30	60	70	12.7	7	M16	3.5	A	HPA 04R
HSK 100A-FMA31.75-105	31.75	105	30	60	70	12.7	7	M16	4.3	A	HPA 04R
HSK 100A-FMA31.75-135	31.75	135	30	60	70	12.7	7	M16	5.1	A	HPA 04R
HSK 100A-FMA38.1-75	38.1	75	34	80	80	15.9	9	M20	4.4	A	HPA 05R
HSK 100A-FMA38.1-105	38.1	105	34	80	80	15.9	9	M20	5.7	A	HPA 05R
HSK 100A-FMA38.1-135	38.1	135	34	80	80	15.9	9	M20	7.0	A	HPA 05R
HSK 100A-FMA50.8-75	50.8	75	36	99	83	19.05	10	M24	5.7	B	HPA 06R
HSK 100A-FMA50.8-105	50.8	105	36	99	83	19.05	10	M24	7.7	B	HPA 06R
HSK 100A-FMA50.8-135	50.8	135	36	99	83	19.05	10	M24	9.7	B	HPA 06R
HSK 100A-FMA47.625-75	47.625	75	38	128.57	83	25.4	12.5	M16		C	HPA 08R

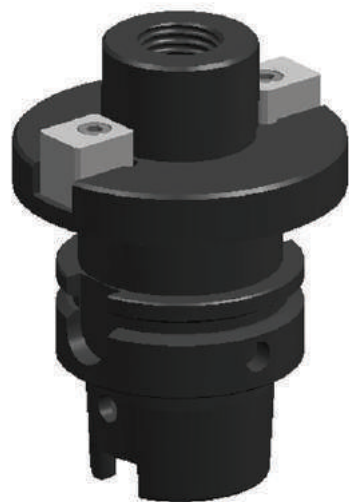

CERAMIC

CERMET

PCBN / PCD

TOOL HOLDER

MILLING CUTTER

CERAMIC

CERMET

PCBN / PCD

TOOL HOLDER

MILLING CUTTER

ALUMINUM CUTTER

MOUNT'G BOLT

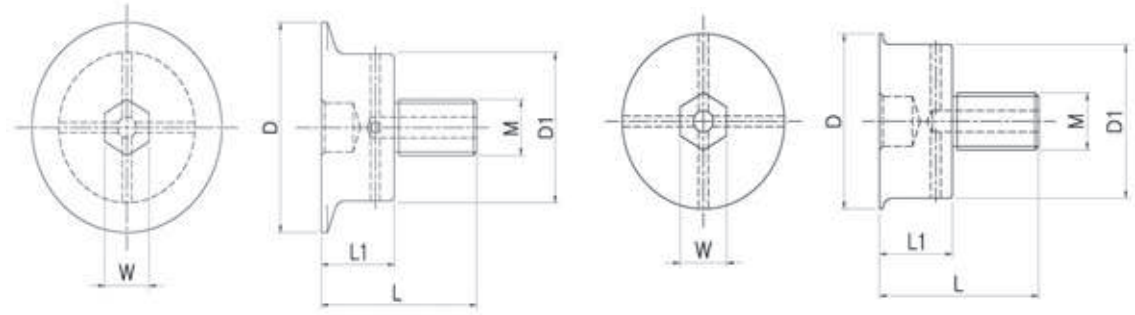

Model A

Model B

Type	Dimensions (mm)					M	Model	Cutter	Arbor
	D	D ₁	L	L ₁	W				
ICM-M10	28	16.5	41	11	8	M10	A	HPA 025R-I09	FMA 22
HCM-M10	25	18	43	10	8	M10	B	HPA 025R-H10	
ICM-M12	44	26	42	15.4	10	M12	A	HPA 03R-I09	FMA 25.4
HCM-M12	40	34	47.5	25.5	12	M12	B	HPA 03R-H10	
ICM-M16	60	43	49	23	14	M16	A	HPA 04R-I09	FMA 31.75
HCM-M16	49	43	48	22	14	M16	B	HPA 04R-H10	
ICM-M20	79	53.6	58.8	27.8	14	M20	A	HPA 05R-I09	FMA 38.1
HCM-M20	60	54	63	32	14	M20	B	HPA 05R-H10	
ICM-M24	110	65	60	22	17	M24	A	HPA 06R-I09	FMA 50.8
HCM-M24	71	65	60	22	17	M24	B	HPA 06R-H10	

ALUMINUM CUTTER

QCB - I

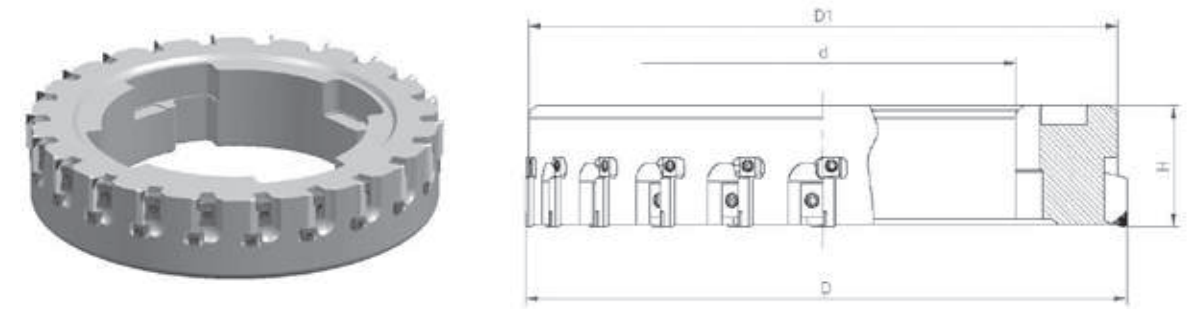

Type	Dimensions (mm)				⚙️	Insert
	D	D ₁	d	H		
QCB D200-I09	200	195	120.02	50	18	HPA-I09
QCB D250-I09	250	245	160.02	50	22	
QCB D315-I09	315	310	215.02	50	28	

Spare parts				
① Insert	② Wedge	③ Wedge Screw	④ Adjust Wedge	⑤ Adjust Wedge Screw
HPA-I09	DT-ST01	WS6-16	DT-ST02	WS5-11

ALUMINUM CUTTER

QCB - H

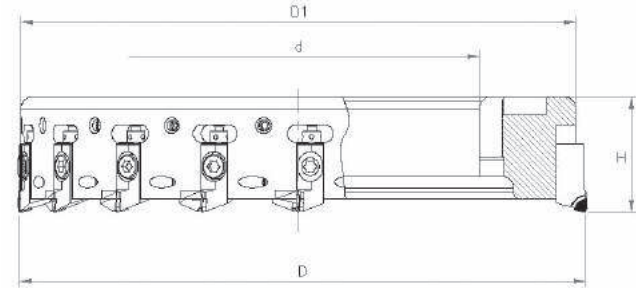
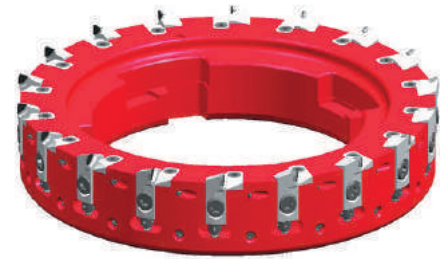

Type	Dimensions (mm)				⚙️	Insert
	D	D ₁	d	H		
QCB D200-H10	200	195	120.02	50	14	HPA 10CA-R HPA 10CA-W
QCB D250-H10	250	245	160.02	50	18	
QCB D315-H10	315	310	215.02	50	22	

Spare parts				
① Cartridge	① Cartridge	② Double Screw	③ Clamp Screw	④ Side Clamp Screw
HPA 10CA-R	HPA 10CA-W	H108	M6x15	M6x16
⑤ Adjust Screw	⑥ Chip Cover	⑦ Chip Cover Screw	⑧ Balancing Screw	
AJM 5F	HC-R/L	M4x10	M6x10	

ALUMINUM CUTTER

ARBOR

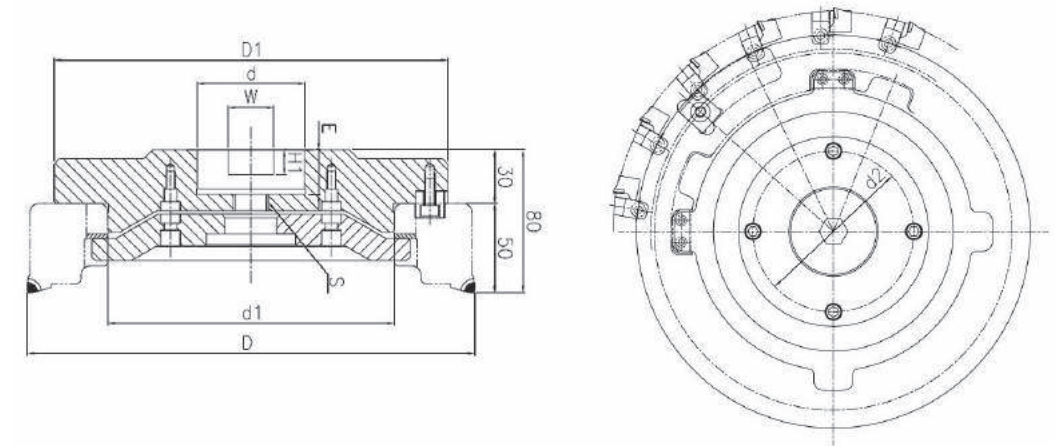

Type	Dimensions (mm)								Center Bolt
	D	D ₁	d	d ₁	W	H ₁	S	E	
QCBA-D200	200	195	47.625	119.97	25.4	14	M20	25	TMBA-M20
QCBA-D250	250	245	60	159.97	25.4	14	M20	25	
QCBA-D315	315	310	60	214.97	25.4	14	M20	25	

E-MOBILITY

MOTOR HOUSING (BORING)

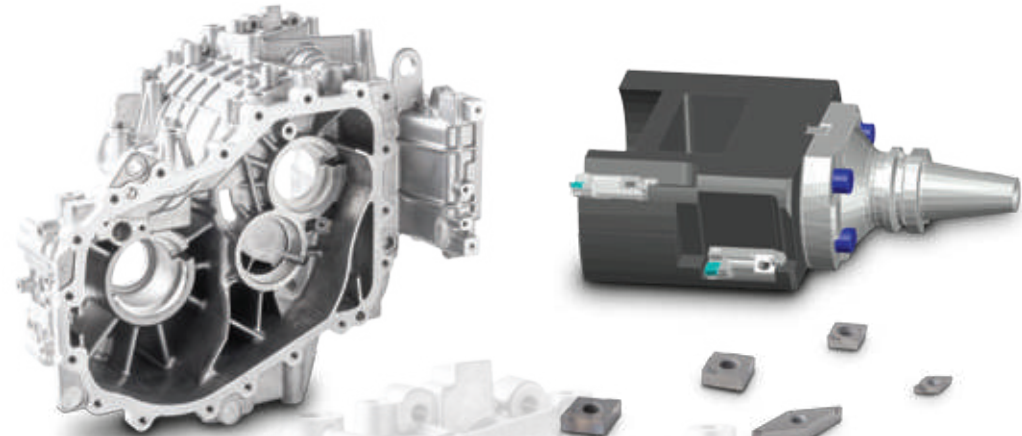

HIGH PRECISION BORING TOOL

- Micro cartridge design
- Light weight design
- PCD equipped ISO inserts (CCGW 1204...)

BATTERY HOUSING (TOP MILLING)



PCD FACE MILLING CUTTER

- PCD Cartridge Type
- Good Surface Roughness
- Light weight design
- Simple handling
- Easy handling
- Very high tool lives

CBN BALL CUTTER / END MILL

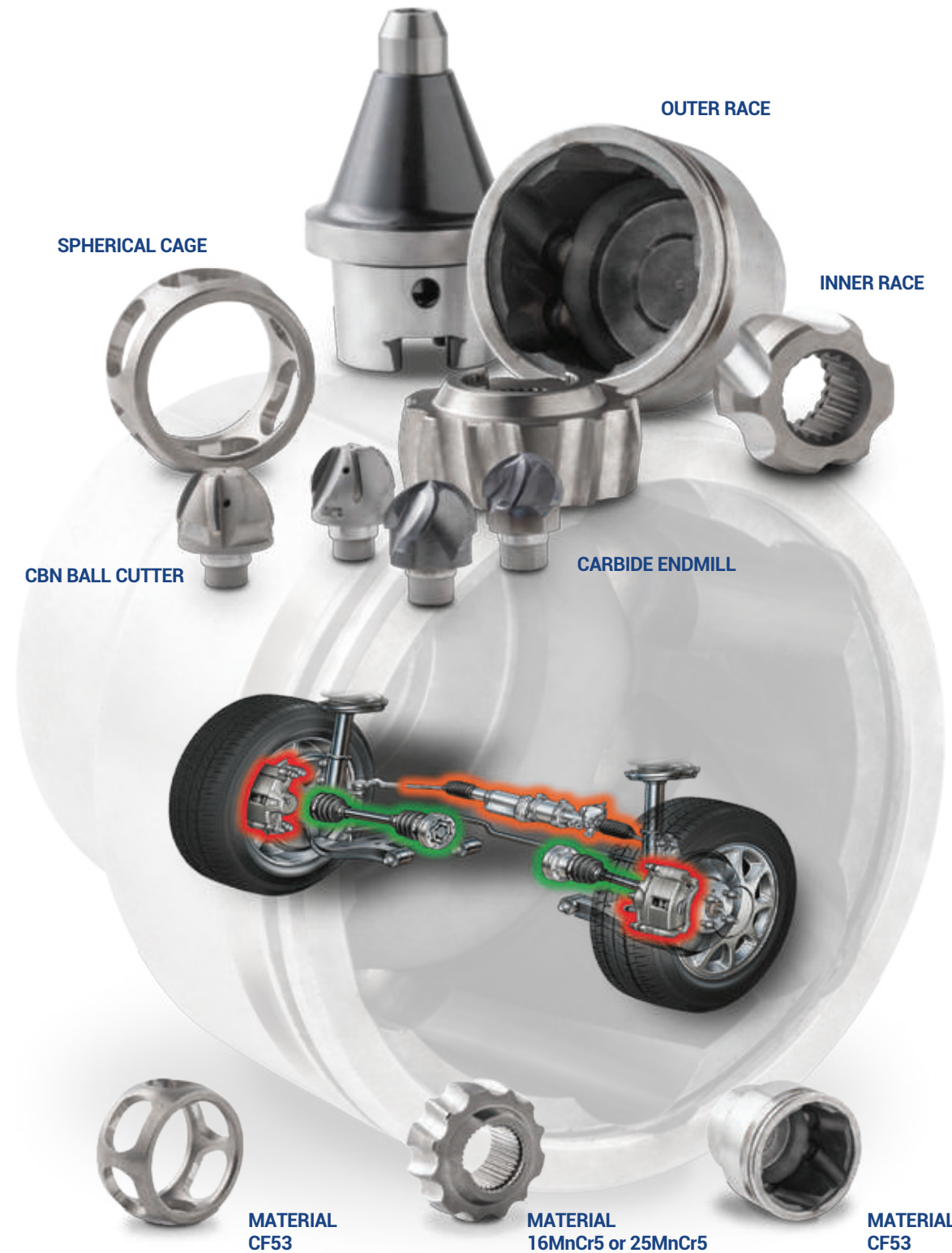

SPHERICAL CAGE

OUTER RACE

INNER RACE

CBN BALL CUTTER

CARBIDE ENDMILL

MATERIAL
CF53

MATERIAL
16MnCr5 or 25MnCr5

MATERIAL
CF53

SPECIAL TOOLS

CYLINDER BLOCK



SPECIAL TOOLS

CYLINDER BLOCK



• REAR FACE MILLING CUTTER

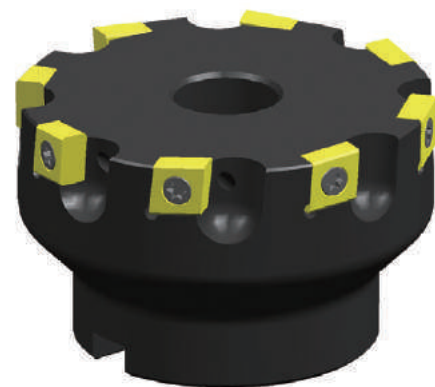

• FACE MOUNTING BOSSES MILLING CUTTER



• OIL MAIN CHANNEL DRILL



• FACE HOLE TRANSMISSION DRILL



• SLOT SPEED SENSOR ENDMILL

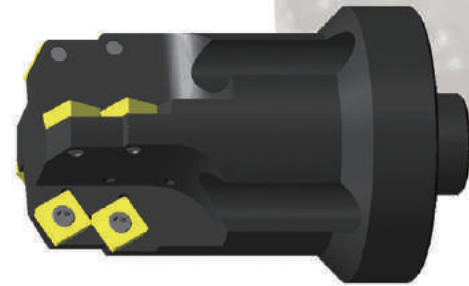

• CUT OUT STARTER BORING TOOL

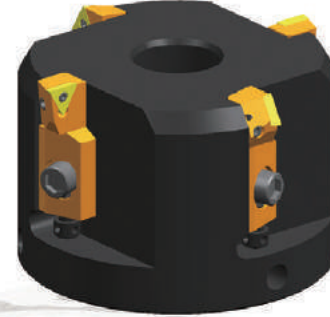

• STOP FACE SEALING CRANK SHAFT BORING TOOL



• CRANK HONING HOLDER

SPECIAL TOOLS

CYLINDER HEAD

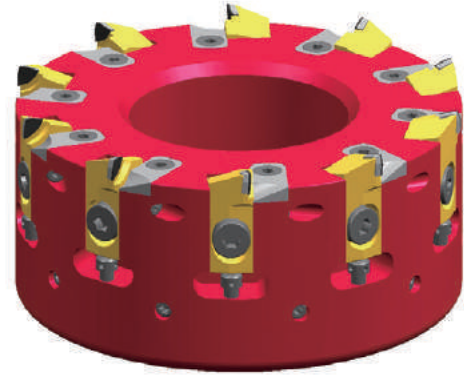

• EXHAUST FACE MILLING CUTTER

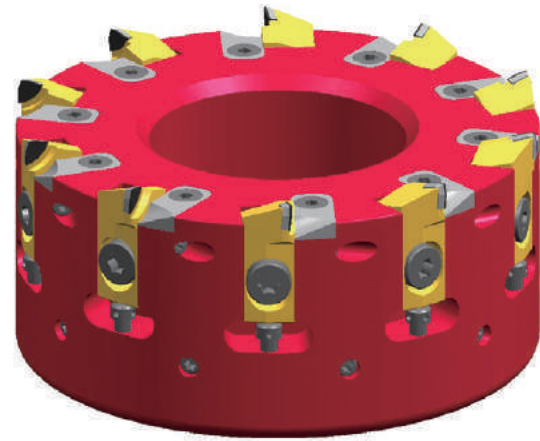

• TOP FACE MILLING CUTTER



• SEAT LIFTER-VALVE IN & EX BORING TOOL



• SEAT LIFTER-VALVE IN & EX BORING TOOL



• SPARK PLUG HOLE REAMER



• VALVE GUIDE SEAT LIFTER VALVE BORING TOOL

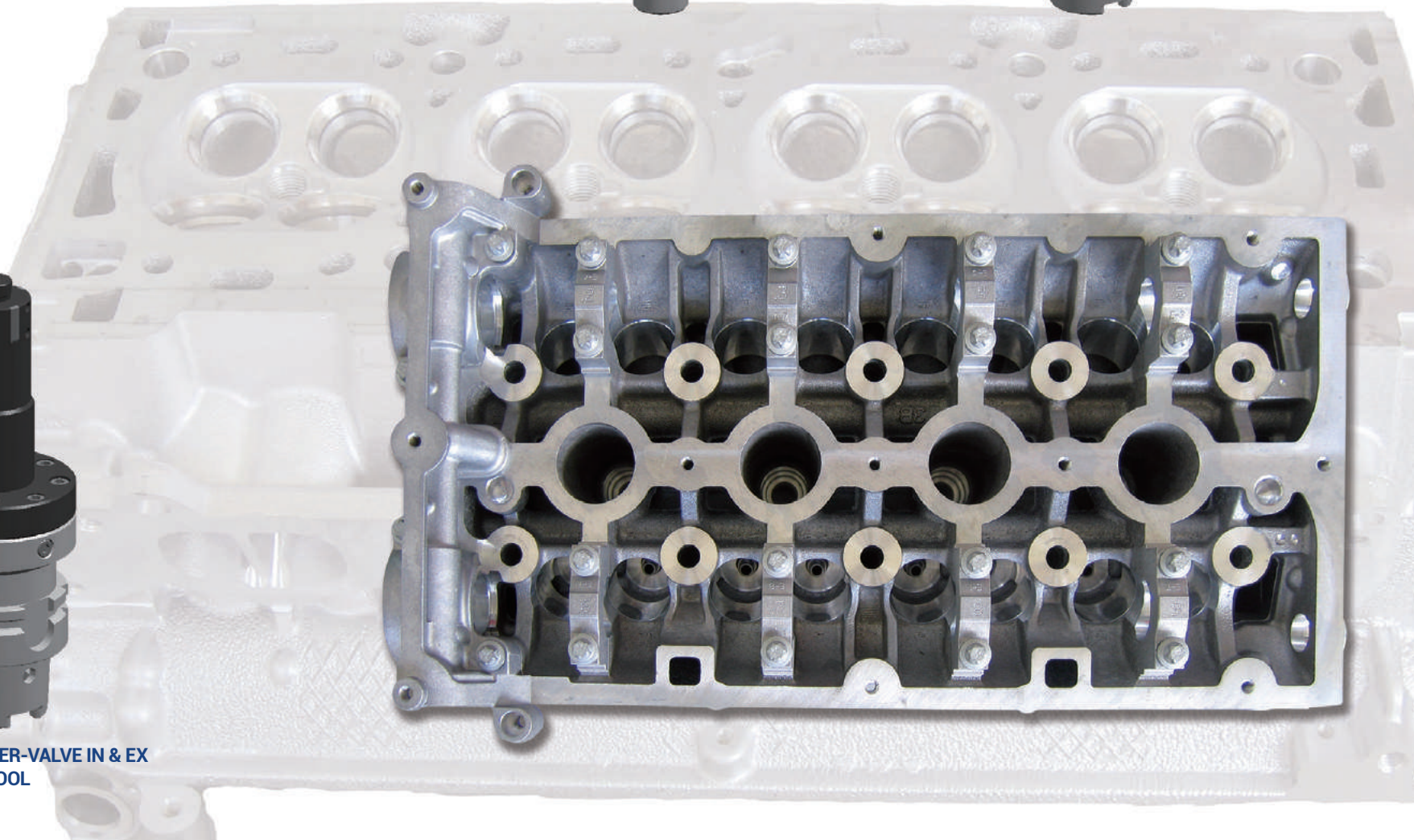

SPECIAL TOOLS

CYLINDER HEAD



• CAMSHAFT BEARING CHAMFER

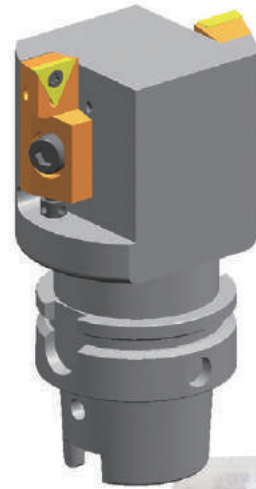

• VALVE SEAT GUIDE BORING TOOL



• CAMSHAFT BEARING FINISH BORING TOOL



• VALVE SEAT GUIDE FINISH BORING TOOL

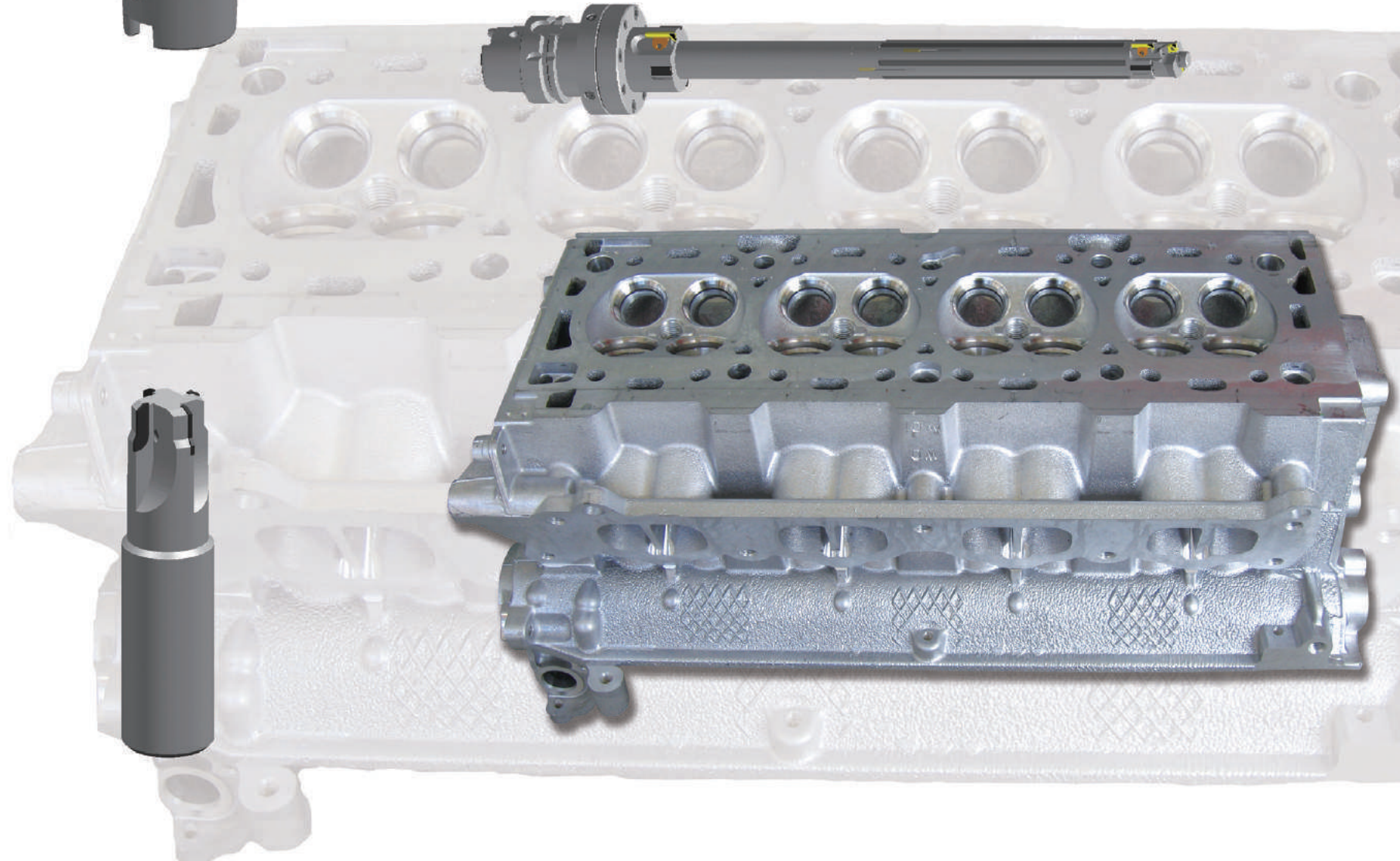

SPECIAL TOOLS

T/MISSION CASE



• GEAR SHIFT SHAFT LOCK HOLE BORING TOOL

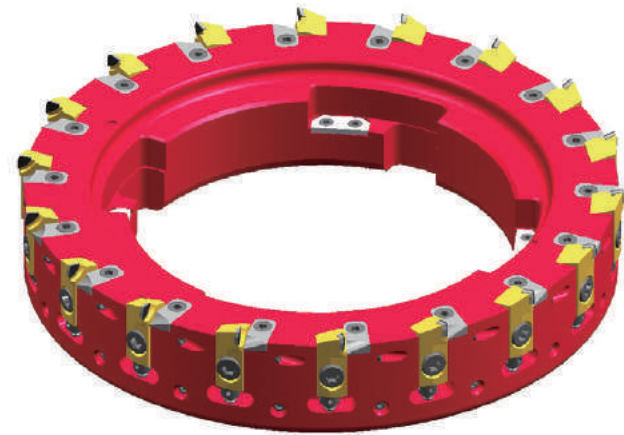

• CLUTCH RELEASE LEVER HOLE REAMER

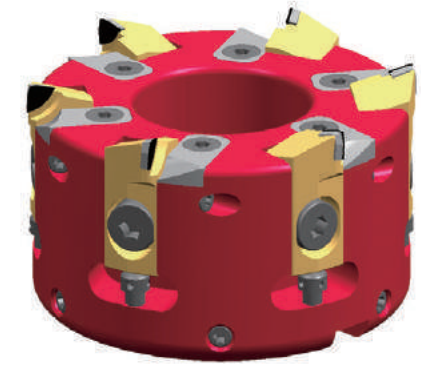

• CPS COVER ATTACHED FACE MILLING CUTTER

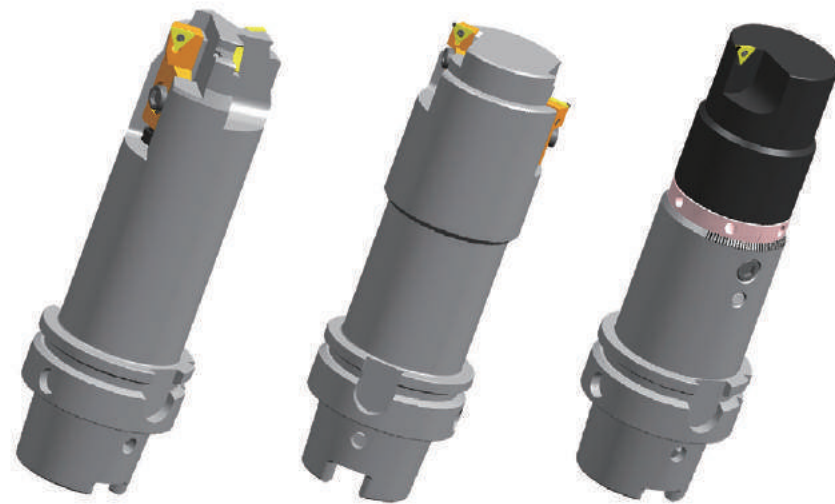

• DIFT HOUSING & OIL SEAL HOLE BORING TOOL

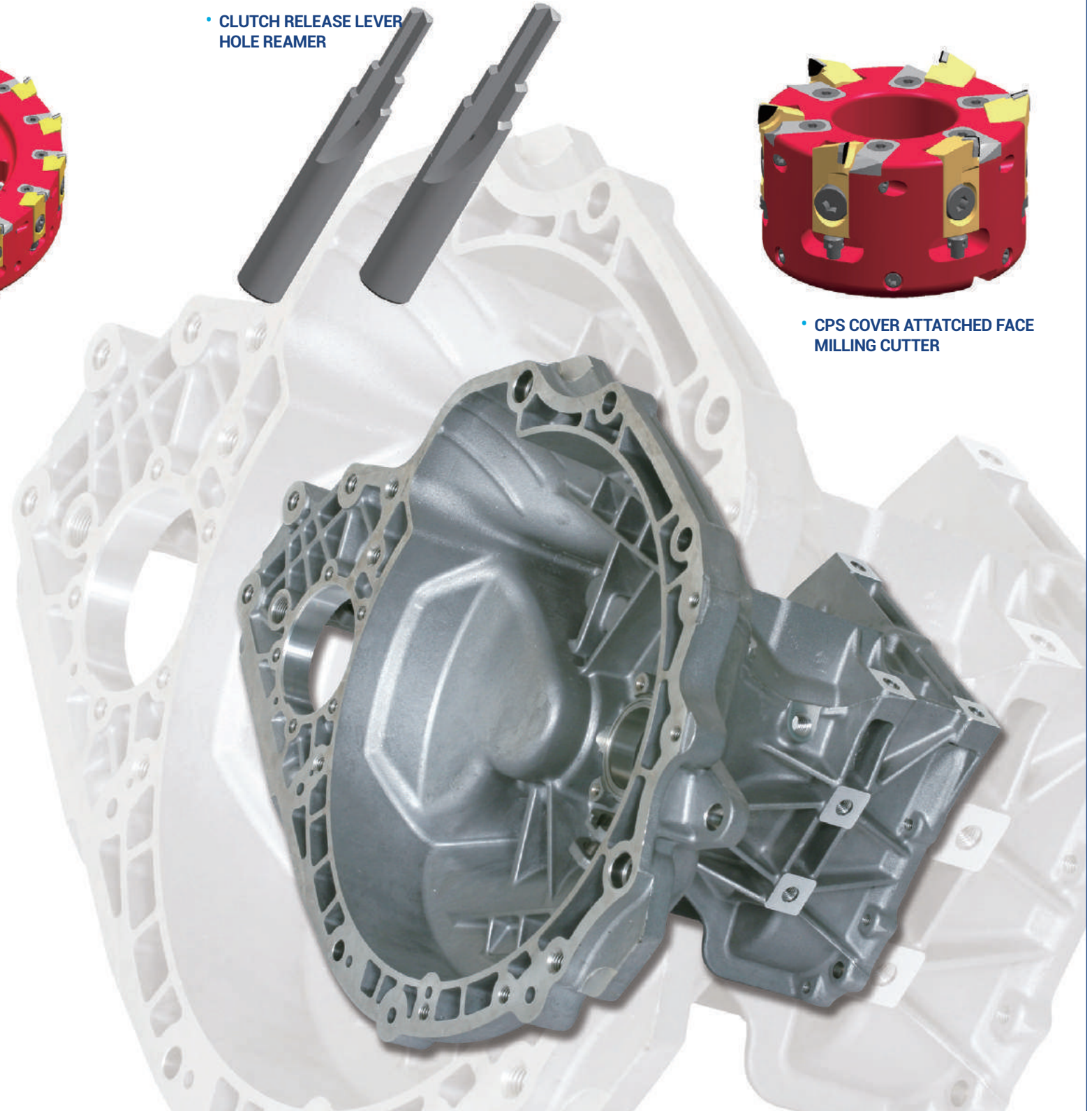

SPECIAL TOOLS

T/MISSION CASE



• COUNTER SHAFT BRG. HOLE BORING TOOL

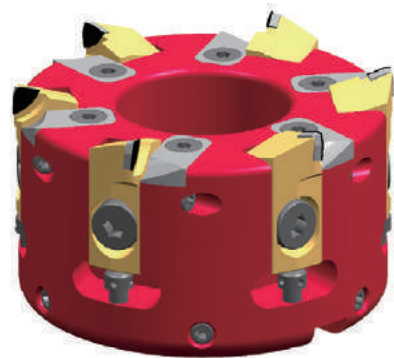
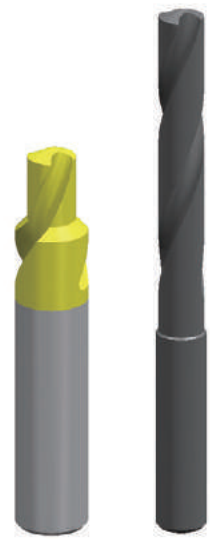

• ENGINE MOUNTING HOLE BORING TOOL



SPECIAL TOOLS

BRAKE HOUSING



BRAKE CARRIER



SPECIAL TOOLS

K N U C K L E

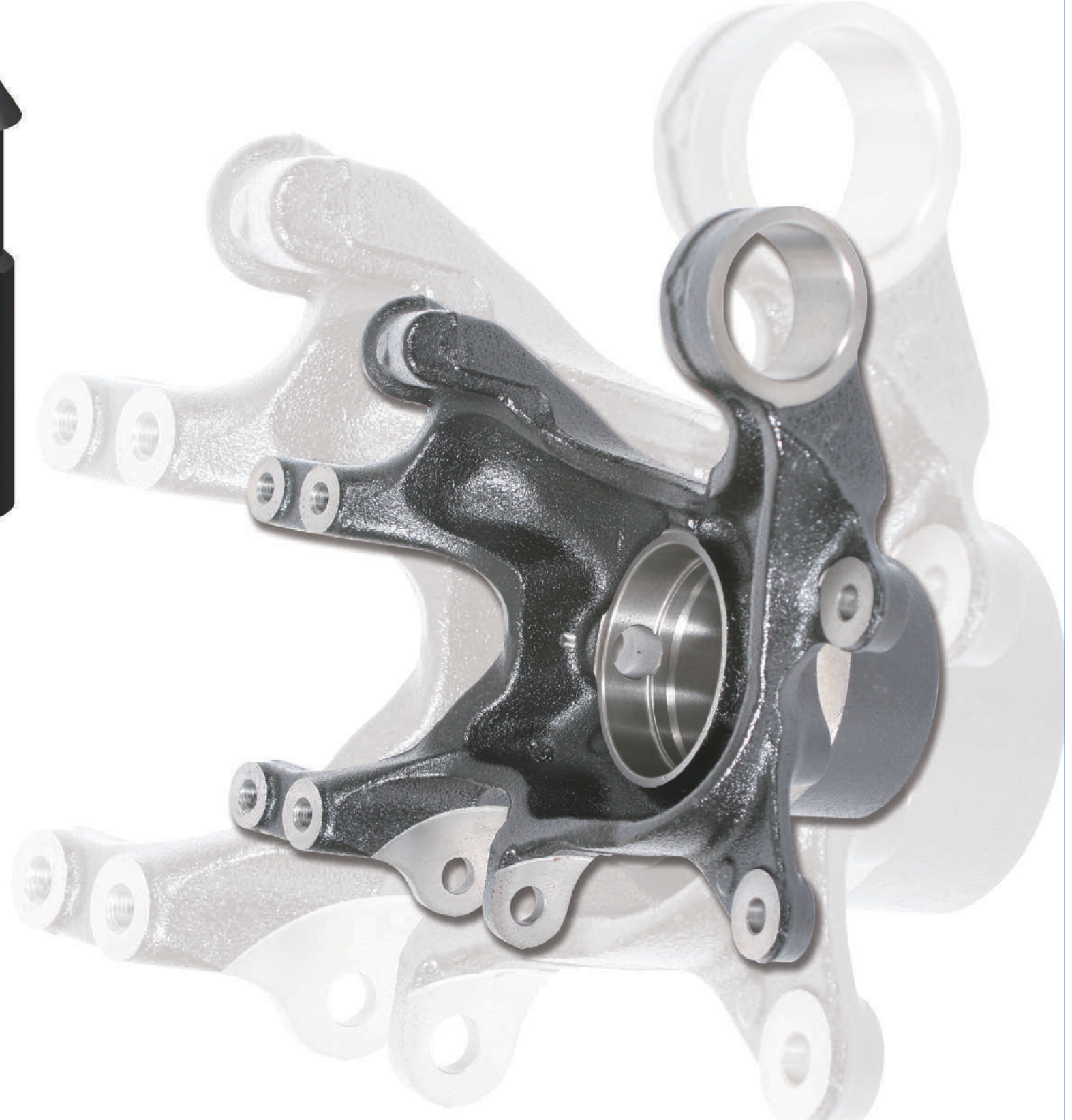

SPECIAL TOOLS

CONNECTING ROD



SPECIAL TOOLS

UF T-Slot Cutters (Solid Carbide)

T-slot cutter generally applies to edge grooving, Keyway grooving, T-slot grooving.



Dia. 2-12mm / 250mm
Note : Please inquire for special size

UF indexbale T-slot cutter : Same shank fits but various carbide inserts

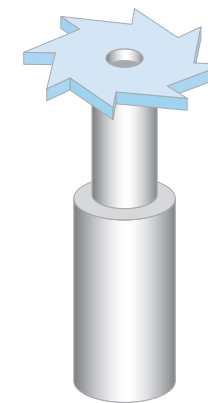

Solid carbide T-slots, the one drawback those cutters have in common is each individual cutter has their own size and single application, users must throw away the entire cutter when it was damaged.

For example, someday when they get a new project needs a cutter in $\varnothing 20\text{mm}$ with shank size $\varnothing 16\text{mm}$; if none of their existing cutters fit the requirement, they have no choice but to buy an all-new cutter.

Therefore, we offer customization options as well, such as, T-Slot inserts with special corner radius, chamfers .. and so on.

Application

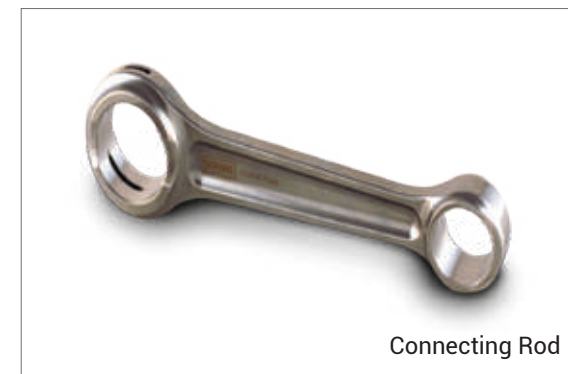

ENDMILL CUTTER

ARE01

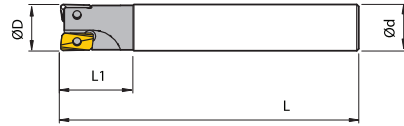

ARE02

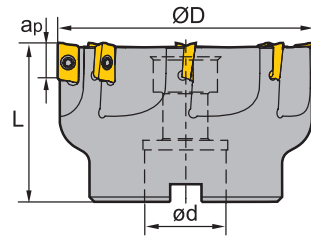

	Type	Dimensions (mm)				⚙️
		ØD	Ød	L1	L	
ARE01	ARE01-016-120-AP11-2F	16	16	25	120	2
	ARE01-016-180-AP11-2F	16	16	30	180	2
	ARE01-020-120-AP11-2F	20	20	30	120	2
	ARE01-020-180-AP11-2F	20	20	30	180	2
	ARE01-025-150-AP11-3F	25	25	35	150	3
	ARE01-025-200-AP11-3F	25	25	35	200	3
	ARE01-025-150-AP16-2F	25	25	35	150	2
	ARE01-025-200-AP16-2F	25	25	35	200	2
	ARE01-032-160-AP16-3F	32	32	40	160	3
ARE01-032-200-AP16-3F	32	32	40	200	3	
ARE02	ARE02-050-A22-AP16-5F	50	22	-	40	5
	ARE02-063-A22-AP16-6F	63	22	-	50	6

Diameter ØD	Insert	Screw	Wrench	
Ø16-Ø25	AP11	DTKA 02555	T-7	-
Ø25-Ø63	AP16	DTKA 04100	-	T-15

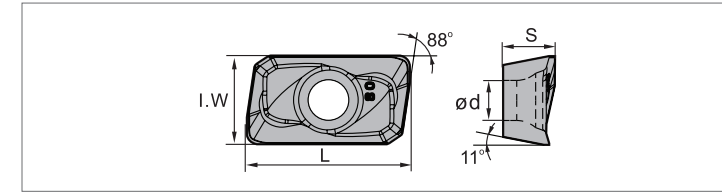

SPG200

- PVD Coating
- P20, M20

Insert shape	Type	Dimensions (mm)					Grade
		L	I.W	S	d	r	
	APMT1135PDR	11.25	6.2	3.5	2.8	0.8	●
	APMT160408PDER	17.25	9.25	4.76	4.4	0.8	●

● Stock

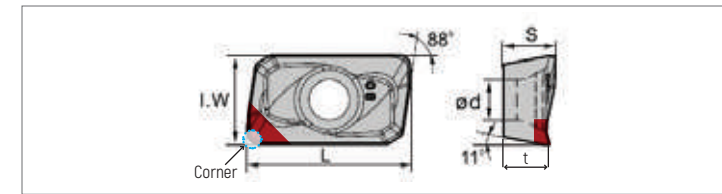

Insert shape	Type	Dimensions (mm)					Grade
		L	I.W	S	d	r	
	APMT1135PDR	11.25	6.2	3.5	2.8	0.8	●
	APMT160408PDER	17.25	9.25	4.76	4.4	0.8	●

HIGH FEED CUTTER

HFC01

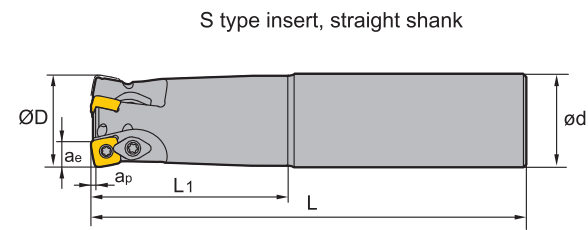

Type	Dimensions (mm)				⚙️	
	ØD	Ød	L ₁	L		
HFC01	HFC01-33-200-SD12-2F	33	32	50	200	2
	HFC01-33-250-SD12-2F	33	32	50	250	2

HFC01

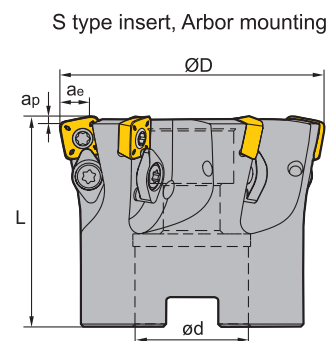

Type	Dimensions (mm)				⚙️	
	ØD	Ød	L ₁	L		
HFC01	HFC01-50-A22-SD12-3F	50	22	-	50	3
	HFC01-63-A22-SD12-4F	63	22	-	50	4

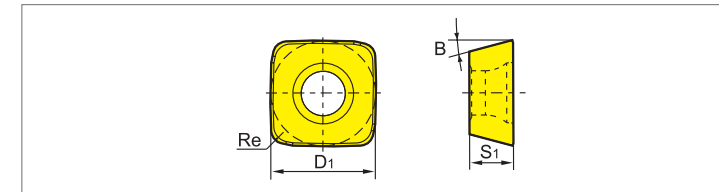

SPG210

- PVD Coating
- P20, M20

Insert shape	Type	Dimensions (mm)				Grade SPG210
		B	Re	S ₁	D ₁	
	SDMT09T312-DM	15°	1.2	3.97	9.525	●
	SDMT120412-DM	15°	2.0	4.76	12.7	●

● Stock

Tool Type	Insert Screw	Clamp Screw	Clamp	Wrench		
	HFC01 □□ -SD12 □□	DTKA 04100	DS 5003-1	DYP 08	T-15	

FINISH BALL CUTTER

FBC

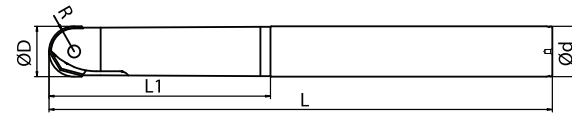

Type	Dimensions (mm)				
	R	ØD	Ød	L ₁	L
FBC 012-130	6	12	12	50	130
FBC 012-150	6	12	12	60	150
FBC 016-150	8	16	16	60	150
FBC 016-180	8	16	16	80	180
FBC 020-180	10	20	20	75	180
FBC 020-220	10	20	20	90	220
FBC 025-200	12.5	25	25	90	200
FBC 025-250	12.5	25	25	110	250
FBC 030-200	15	30	30	90	200
FBC 030-250	15	30	30	110	250
FBC 030-300	15	30	30	125	300

Diameter	Screw	Wrench
Ø12	DBF 1210	T-15
Ø16	DBF 1611	T-15
Ø20	DBF 20165	T-20
Ø25	DBF 2520	T-25
Ø30	DBF 3025	L-5

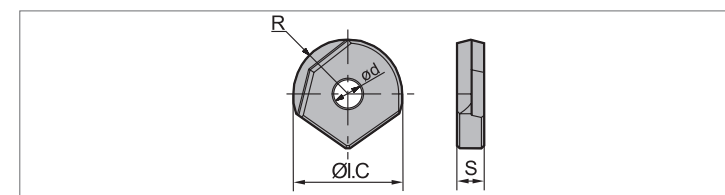

SPG250

- PVD Coating
- P20, M20, K20

Insert shape	Type	Dimensions (mm)					Grade
		R	ØI.C	S	Ød	ØD	SPG250
	DFBI1203-M/F	6	12	3	4	Ø12	●
	DFBI1604-M/F	8	16	4	5	Ø16	●
	DFBI2005-M/F	10	20	5	5	Ø20	●
	DFBI2506-M/F	12.5	25	6	6	Ø25	●
	DFBI3007-M/F	15	30	7	8.25	Ø30	●

● Stock

FACE MILL CUTTER

OMR07

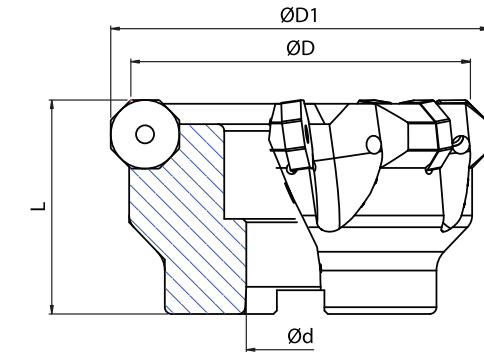
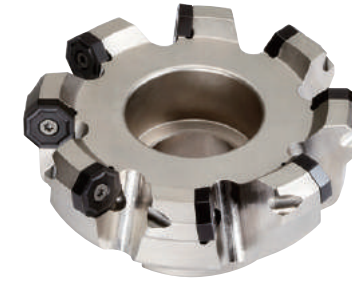

Type	Dimensions (mm)				Gear Icon
	ØD	Ød	L ₁	L	
OMR07-080-B27-ON08-06	80	92	27	50	6
OMR07-100-B32-ON08-07	100	111	32	63	7
OMR07-125-B40-ON08-08	125	138	40	63	8

Diameter ØD	Insert	Screw	Wrench
Ø63-Ø315	ONHU 08 □□□□-PF/PM	DTKA512-60	T-20

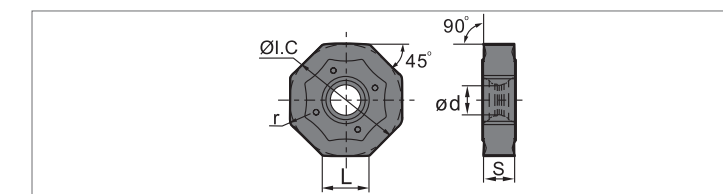

SCK150

- CVD Coating
- K15

Insert shape	Type	Dimensions (mm)					Grade
		L	ØI.C	S	Ød	r	SCK150
	ONHU08T508-PF	8.37	20.2	5.77	5.3	0.83	
	ONHU08T508-PM	8.37	20.2	5.79	5.3	0.83	●

● Stock

INDEXIBLE DRILL

JTR 2xD

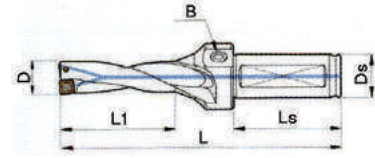

Type	D	L ₁	L	D _s	L _s	B	Insert	Screw	Wrench			
JTR-12520D	12.5	28	105	20	50	PT-1/8	SPGT050204-PM	TSB-20045	TXL-6			
JTR-13020D	13.0	29	106	20	50	PT-1/8						
JTR-13520D	13.5	30	107	20	50	PT-1/8						
JTR-14020D	14.0	31	108	20	50	PT-1/8						
JTR-14520D	14.5	32	109	20	50	PT-1/8						
JTR-15020D	15.0	33	110	20	50	PT-1/8						
JTR-15520D	15.5	34	120	25	56	PT-1/8	SPGT060204-PM	TSB-22052	TXL-6			
JTR-16020D	16.0	35	121	25	56	PT-1/8						
JTR-16520D	16.5	36	122	25	56	PT-1/8						
JTR-17020D	17.0	37	123	25	56	PT-1/8						
JTR-17520D	17.5	38	124	25	56	PT-1/8						
JTR-18020D	18.0	39	125	25	56	PT-1/8						
JTR-18520D	18.5	40	126	25	56	PT-1/8						
JTR-19020D	19.0	41	127	25	56	PT-1/8						
JTR-19520D	19.5	42	128	25	56	PT-1/8						
JTR-20020D	20.0	43	129	25	56	PT-1/8						
JTR-20520D	20.5	44	130	25	56	PT-1/8						
JTR-21020D	21.0	45	131	25	56	PT-1/8						
JTR-21520D	21.5	46	132	25	56	PT-1/8						
JTR-22020D	22.0	47	133	32	60	PT-1/4	SPGT07T308-PM	TSB-25065	TXL-8			
JTR-22520D	22.5	48	143	32	60	PT-1/4						
JTR-23020D	23.0	49	144	32	60	PT-1/4						
JTR-23520D	23.5	50	145	32	60	PT-1/4						
JTR-24020D	24.0	51	146	32	60	PT-1/4						
JTR-24520D	24.5	52	147	32	60	PT-1/4						
JTR-25020D	25.0	53	148	32	60	PT-1/4						
JTR-25520D	25.5	54	149	32	60	PT-1/4						
JTR-26020D	26.0	55	150	32	60	PT-1/4						
JTR-26520D	26.5	56	151	32	60	PT-1/4						
JTR-27020D	27.0	57	152	32	60	PT-1/4						
JTR-27520D	27.5	58	153	32	60	PT-1/4						
JTR-28020D	28.0	59	154	32	60	PT-1/4	SPGT090408-PM	TSB-35090	TXL-15			
JTR-28520D	28.5	60	155	32	60	PT-1/4						
JTR-29020D	29.0	61	156	32	60	PT-1/4						
JTR-29520D	29.5	64	159	32	60	PT-1/4						
JTR-30020D	30.0	65	160	32	60	PT-1/4						
JTR-31020D	31.0	67	162	32	60	PT-1/4						
JTR-32020D	32.0	69	164	32	60	PT-1/4						
JTR-33020D	33.0	71	166	32	60	PT-1/4						
JTR-34020D	34.0	73	168	32	70	PT-1/4				SPGT110408-PM	TSB-40100	TXL-15
JTR-35020D	35.0	75	170	32	70	PT-1/4						
JTR-36020D	36.0	77	172	32	70	PT-1/4						
JTR-37020D	37.0	79	189	40	70	PT-1/4						
JTR-38020D	38.0	81	191	40	70	PT-1/4						
JTR-39020D	39.0	83	193	40	70	PT-1/4						
JTR-40020D	40.0	85	195	40	70	PT-1/4	SPGT140512-PM	TSB-50125	TXL-20			
JTR-41020D	41.0	87	197	40	70	PT-1/4						
JTR-42020D	42.0	89	199	40	70	PT-1/4						
JTR-43020D	43.0	91	201	40	70	PT-1/4						
JTR-44020D	44.0	93	203	40	70	PT-1/4						
JTR-45020D	45.0	95	205	40	70	PT-1/4						
JTR-46020D	46.0	97	207	40	70	PT-1/4						
JTR-47020D	47.0	99	209	40	70	PT-1/4						
JTR-48020D	48.0	101	211	40	70	PT-1/4						
JTR-49020D	49.0	103	213	40	70	PT-1/4						
JTR-50020D	50.0	105	215	40	70	PT-1/4						

TURNING
&
MILLING

CERAMIC

CERMET

PCBN / PCD

TOOL HOLDER

MILLING CUTTER

INDEXIBLE DRILL

JTR 3xD

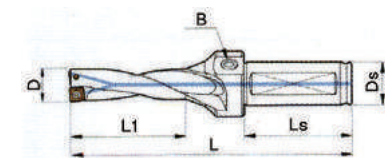

Type	D	L ₁	L	D _s	L _s	B	Insert	Screw	Wrench			
JTR-12530D	12.5	41	118	20	50	PT-1/8	SPGT050204-PM	TSB-20045	TXL-6			
JTR-13030D	13.0	42	119	20	50	PT-1/8						
JTR-13530D	13.5	44	121	20	50	PT-1/8						
JTR-14030D	14.0	45	122	20	50	PT-1/8						
JTR-14530D	14.5	47	124	20	50	PT-1/8						
JTR-15030D	15.0	48	125	20	50	PT-1/8						
JTR-15530D	15.5	50	136	25	56	PT-1/8	SPGT060204-PM	TSB-22052	TXL-6			
JTR-16030D	16.0	51	137	25	56	PT-1/8						
JTR-16530D	16.5	53	139	25	56	PT-1/8						
JTR-17030D	17.0	54	140	25	56	PT-1/8						
JTR-17530D	17.5	56	142	25	56	PT-1/8						
JTR-18030D	18.0	57	143	25	56	PT-1/8						
JTR-18530D	18.5	59	145	25	56	PT-1/8						
JTR-19030D	19.0	60	146	25	56	PT-1/8						
JTR-19530D	19.5	62	148	25	56	PT-1/8						
JTR-20030D	20.0	63	149	25	56	PT-1/8						
JTR-20530D	20.5	65	151	25	56	PT-1/8						
JTR-21030D	21.0	66	152	25	56	PT-1/8						
JTR-21530D	21.5	68	154	25	56	PT-1/8						
JTR-22030D	22.0	69	155	32	60	PT-1/4	SPGT07T308-PM	TSB-25065	TXL-8			
JTR-22530D	22.5	71	166	32	60	PT-1/4						
JTR-23030D	23.0	72	167	32	60	PT-1/4						
JTR-23530D	23.5	74	169	32	60	PT-1/4						
JTR-24030D	24.0	75	170	32	60	PT-1/4						
JTR-24530D	24.5	77	172	32	60	PT-1/4						
JTR-25030D	25.0	78	173	32	60	PT-1/4						
JTR-25530D	25.5	80	175	32	60	PT-1/4						
JTR-26030D	26.0	81	176	32	60	PT-1/4						
JTR-26530D	26.5	83	178	32	60	PT-1/4						
JTR-27030D	27.0	84	179	32	60	PT-1/4						
JTR-27530D	27.5	86	181	32	60	PT-1/4						
JTR-28030D	28.0	87	182	32	60	PT-1/4	SPGT090408-PM	TSB-35090	TXL-15			
JTR-28530D	28.5	89	184	32	60	PT-1/4						
JTR-29030D	29.0	90	185	32	60	PT-1/4						
JTR-29530D	29.5	94	189	32	60	PT-1/4						
JTR-30030D	30.0	95	190	32	60	PT-1/4						
JTR-31030D	31.0	98	193	32	60	PT-1/4						
JTR-32030D	32.0	101	196	32	60	PT-1/4						
JTR-33030D	33.0	104	199	32	60	PT-1/4						
JTR-34030D	34.0	107	202	32	70	PT-1/4				SPGT110408-PM	TSB-40100	TXL-15
JTR-35030D	35.0	110	205	32	70	PT-1/4						
JTR-36030D	36.0	113	208	32	70	PT-1/4						
JTR-37030D	37.0	116	226	40	70	PT-1/4						
JTR-38030D	38.0	119	229	40	70	PT-1/4						
JTR-39030D	39.0	122	232	40	70	PT-1/4						
JTR-40030D	40.0	125	235	40	70	PT-1/4	SPGT140512-PM	TSB-50125	TXL-20			
JTR-41030D	41.0	128	238	40	70	PT-1/4						
JTR-42030D	42.0	131	241	40	70	PT-1/4						
JTR-43030D	43.0	134	244	40	70	PT-1/4						
JTR-44030D	44.0	137	247	40	70	PT-1/4						
JTR-45030D	45.0	140	250	40	70	PT-1/4						
JTR-46030D	46.0	143	253	40	70	PT-1/4						
JTR-47030D	47.0	146	256	40	70	PT-1/4						
JTR-48030D	48.0	149	259	40	70	PT-1/4						
JTR-49030D	49.0	152	262	40	70	PT-1/4						
JTR-50030D	50.0	155	265	40	70	PT-1/4						

TURNING
&
MILLING

CERAMIC

CERMET

PCBN / PCD

TOOL HOLDER

MILLING CUTTER

INDEXIBLE DRILL

JTR 4×D

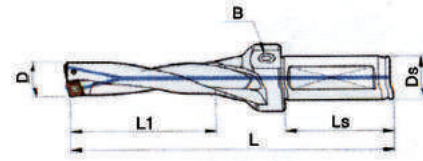

Type	D	L ₁	L	D _s	L _s	B	Insert	Screw	Wrench
JTR-12540D	12.5	53	130	20	50	PT-1/8	SPGT050204-PM	TSB-20045	TXL-6
JTR-13040D	13.0	55	132	20	50	PT-1/8			
JTR-13540D	13.5	57	134	20	50	PT-1/8			
JTR-14040D	14.0	59	136	20	50	PT-1/8			
JTR-14540D	14.5	61	138	20	50	PT-1/8			
JTR-15040D	15.0	63	140	20	50	PT-1/8			
JTR-15540D	15.5	65	151	25	56	PT-1/8	SPGT060204-PM	TSB-22052	TXL-6
JTR-16040D	16.0	67	153	25	56	PT-1/8			
JTR-16540D	16.5	69	155	25	56	PT-1/8			
JTR-17040D	17.0	71	157	25	56	PT-1/8			
JTR-17540D	17.5	73	159	25	56	PT-1/8			
JTR-18040D	18.0	75	161	25	56	PT-1/8			
JTR-18540D	18.5	77	163	25	56	PT-1/8			
JTR-19040D	19.0	79	165	25	56	PT-1/8			
JTR-19540D	19.5	81	167	25	56	PT-1/8			
JTR-20040D	20.0	83	169	25	56	PT-1/8			
JTR-20540D	20.5	85	171	25	56	PT-1/8			
JTR-21040D	21.0	87	173	25	56	PT-1/8			
JTR-21540D	21.5	89	175	25	56	PT-1/8			
JTR-22040D	22.0	91	177	32	60	PT-1/4	SPGT07T308-PM	TSB-25065	TXL-8
JTR-22540D	22.5	93	188	32	60	PT-1/4			
JTR-23040D	23.0	95	190	32	60	PT-1/4			
JTR-23540D	23.5	97	192	32	60	PT-1/4			
JTR-24040D	24.0	99	194	32	60	PT-1/4			
JTR-24540D	24.5	101	196	32	60	PT-1/4			
JTR-25040D	25.0	103	198	32	60	PT-1/4			
JTR-25540D	25.5	105	200	32	60	PT-1/4			
JTR-26040D	26.0	107	202	32	60	PT-1/4			
JTR-26540D	26.5	109	204	32	60	PT-1/4			
JTR-27040D	27.0	111	206	32	60	PT-1/4			
JTR-27540D	27.5	113	208	32	60	PT-1/4			
JTR-28040D	28.0	115	210	32	60	PT-1/4	SPGT090408-PM	TSB-35090	TXL-15
JTR-28540D	28.5	117	212	32	60	PT-1/4			
JTR-29040D	29.0	119	214	32	60	PT-1/4			
JTR-29540D	29.5	123	218	32	60	PT-1/4			
JTR-30040D	30.0	125	220	32	60	PT-1/4			
JTR-31040D	31.0	129	224	32	60	PT-1/4			
JTR-32040D	32.0	133	228	32	60	PT-1/4	SPGT110408-PM	TSB-40100	TXL-15
JTR-33040D	33.0	137	232	32	60	PT-1/4			
JTR-34040D	34.0	141	236	32	70	PT-1/4			
JTR-35040D	35.0	145	240	32	70	PT-1/4			
JTR-36040D	36.0	149	244	32	70	PT-1/4			
JTR-37040D	37.0	153	263	40	70	PT-1/4			
JTR-38040D	38.0	157	267	40	70	PT-1/4	SPGT140512-PM	TSB-50125	TXL-20
JTR-39040D	39.0	161	271	40	70	PT-1/4			
JTR-40040D	40.0	165	275	40	70	PT-1/4			
JTR-41040D	41.0	169	279	40	70	PT-1/4			
JTR-42040D	42.0	173	283	40	70	PT-1/4			
JTR-43040D	43.0	177	287	40	70	PT-1/4			
JTR-44040D	44.0	181	291	40	70	PT-1/4			
JTR-45040D	45.0	185	295	40	70	PT-1/4			
JTR-46040D	46.0	189	299	40	70	PT-1/4			
JTR-47040D	47.0	193	303	40	70	PT-1/4			
JTR-48040D	48.0	197	307	40	70	PT-1/4			
JTR-49040D	49.0	201	311	40	70	PT-1/4			
JTR-50040D	50.0	205	315	40	70	PT-1/4			

INDEXIBLE DRILL

JSFD 2×D

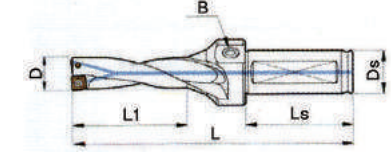

Type	D	L ₁	L	D _s	L _s	B	Insert	Screw	Wrench
JSFD-16020D	16	37	114	20	50	PT-1/8	WCMX030208R-PG	TSB-22045 (ZSB-22045)	TXL-6
JSFD-17020D	17	39	116	20	50	PT-1/8			
JSFD-18020D	18	41	118	20	50	PT-1/8			
JSFD-19020D	19	43	120	20	50	PT-1/8			
JSFD-20020D	20	45	122	20	50	PT-1/8			
JSFD-21020D	21	47	134	25	60	PT-1/8			
JSFD-22020D	22	49	136	25	60	PT-1/8			
JSFD-23020D	23	51	138	25	60	PT-1/8			
JSFD-24020D	24	53	140	25	60	PT-1/8			
JSFD-25020D	25	55	142	25	60	PT-1/8			
JSFD-26020D	26	57	157	32	70	PT-1/4	WCMX050308R-PG	TSB-30070 (ZSB-30070)	TXL-8
JSFD-27020D	27	59	159	32	70	PT-1/4			
JSFD-28020D	28	61	161	32	70	PT-1/4			
JSFD-29020D	29	63	163	32	70	PT-1/4			
JSFD-30020D	30	65	165	32	70	PT-1/4			
JSFD-31020D	31	67	167	32	70	PT-1/4			
JSFD-32020D	32	69	169	32	70	PT-1/4			
JSFD-33020D	33	71	171	32	70	PT-1/4			
JSFD-34020D	34	73	173	32	70	PT-1/4			
JSFD-35020D	35	75	175	32	70	PT-1/4			
JSFD-36020D	36	77	177	32	70	PT-1/4			
JSFD-37020D	37	79	179	32	70	PT-1/4			
JSFD-38020D	38	81	181	32	70	PT-1/4			
JSFD-39020D	39	83	183	32	70	PT-1/4			
JSFD-40020D	40	85	185	32	70	PT-1/4			
JSFD-41020D	41	87	187	32	70	PT-1/4			
JSFD-42020D	42	89	199	40	80	PT-1/4	WCMX080412R-PG	TSB-40110 (ZSB-40110)	TXL-15
JSFD-43020D	43	91	201	40	80	PT-1/4			
JSFD-44020D	44	93	203	40	80	PT-1/4			
JSFD-45020D	45	95	205	40	80	PT-1/4			
JSFD-46020D	46	97	207	40	80	PT-1/4			
JSFD-47020D	47	99	209	40	80	PT-1/4			
JSFD-48020D	48	101	211	40	80	PT-1/4			
JSFD-49020D	49	103	213	40	80	PT-1/4			
JSFD-50020D	50	105	215	40	80	PT-1/4			
JSFD-51020D	51	107	217	40	80	PT-1/4			
JSFD-52020D	52	109	219	40	80	PT-1/4			
JSFD-53020D	53	111	221	40	80	PT-1/4			
JSFD-54020D	54	113	223	40	80	PT-1/4			
JSFD-55020D	55	115	225	40	80	PT-1/4			
JSFD-56020D	56	117	227	40	80	PT-1/4			
JSFD-57020D	57	119	229	40	80	PT-1/4			
JSFD-58020D	58	121	231	40	80	PT-1/4			

* TSB : Big screw head / ZSB : Small screw head

INDEXIBLE DRILL

JSFD 3×D

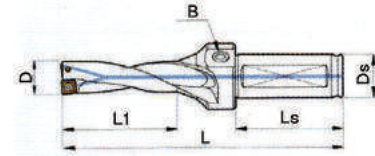

Type	D	L ₁	L	D _s	L _s	B	Insert	Screw	Wrench
JSFD-16030D	16	53	130	20	50	PT-1/8	WCMX030208R-PG	TSB-22045 (ZSB-22045)	TXL-6
JSFD-17030D	17	56	133	20	50	PT-1/8			
JSFD-18030D	18	59	136	20	50	PT-1/8			
JSFD-19030D	19	62	139	20	50	PT-1/8			
JSFD-20030D	20	65	142	20	50	PT-1/8			
JSFD-21030D	21	68	155	25	60	PT-1/8	WCMX040208R-PG	TSB-25055 (ZSB-25055)	TXL-8
JSFD-22030D	22	71	158	25	60	PT-1/8			
JSFD-23030D	23	74	161	25	60	PT-1/8			
JSFD-24030D	24	77	164	25	60	PT-1/8			
JSFD-25030D	25	80	167	25	60	PT-1/8			
JSFD-26030D	26	83	183	32	70	PT-1/4	WCMX050308R-PG	TSB-30070 (ZSB-30070)	TXL-8
JSFD-27030D	27	86	186	32	70	PT-1/4			
JSFD-28030D	28	89	189	32	70	PT-1/4			
JSFD-29030D	29	92	192	32	70	PT-1/4			
JSFD-30030D	30	95	195	32	70	PT-1/4			
JSFD-31030D	31	98	198	32	70	PT-1/4	WCMX06T308R-PG	TSB-35090 (ZSB-35090)	TXL-15
JSFD-32030D	32	101	201	32	70	PT-1/4			
JSFD-33030D	33	104	204	32	70	PT-1/4			
JSFD-34030D	34	107	207	32	70	PT-1/4			
JSFD-35030D	35	110	210	32	70	PT-1/4			
JSFD-36030D	36	113	213	32	70	PT-1/4	WCMX080412R-PG	TSB-40110 (ZSB-40110)	TXL-15
JSFD-37030D	37	116	216	32	70	PT-1/4			
JSFD-38030D	37	119	219	32	70	PT-1/4			
JSFD-39030D	39	122	222	32	70	PT-1/4			
JSFD-40030D	40	125	225	32	70	PT-1/4			
JSFD-41030D	41	128	228	32	70	PT-1/4	WCMX080412R-PG	TSB-40110 (ZSB-40110)	TXL-15
JSFD-42030D	42	131	241	40	80	PT-1/4			
JSFD-43030D	43	134	244	40	80	PT-1/4			
JSFD-44030D	44	137	247	40	80	PT-1/4			
JSFD-45030D	45	140	250	40	80	PT-1/4			
JSFD-46030D	46	143	253	40	80	PT-1/4	WCMX080412R-PG	TSB-40110 (ZSB-40110)	TXL-15
JSFD-47030D	47	146	256	40	80	PT-1/4			
JSFD-48030D	48	149	259	40	80	PT-1/4			
JSFD-49030D	49	152	262	40	80	PT-1/4			
JSFD-50030D	50	155	265	40	80	PT-1/4			
JSFD-51030D	51	158	268	40	80	PT-1/4	WCMX080412R-PG	TSB-40110 (ZSB-40110)	TXL-15
JSFD-52030D	52	161	271	40	80	PT-1/4			
JSFD-53030D	53	164	274	40	80	PT-1/4			
JSFD-54030D	54	167	277	40	80	PT-1/4			
JSFD-55030D	55	170	280	40	80	PT-1/4			
JSFD-56030D	56	173	283	40	80	PT-1/4	WCMX080412R-PG	TSB-40110 (ZSB-40110)	TXL-15
JSFD-57030D	57	176	286	40	80	PT-1/4			
JSFD-58030D	58	179	289	40	80	PT-1/4			

* TSB : Big screw head / ZSB : Small screw head

INDEXIBLE DRILL

JSFD 4×D

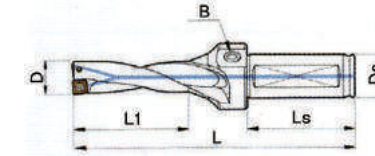

Type	D	L ₁	L	D _s	L _s	B	Insert	Screw	Wrench
JSFD-16040D	16	69	146	20	50	PT-1/8	WCMX030208R-PG	TSB-22045 (ZSB-22045)	TXL-6
JSFD-17040D	17	73	150	20	50	PT-1/8			
JSFD-18040D	18	77	154	20	50	PT-1/8			
JSFD-19040D	19	81	158	20	50	PT-1/8			
JSFD-20040D	20	85	162	20	50	PT-1/8			
JSFD-21040D	21	89	176	25	60	PT-1/8	WCMX040208R-PG	TSB-25055 (ZSB-25055)	TXL-8
JSFD-22040D	22	93	180	25	60	PT-1/8			
JSFD-23040D	23	97	184	25	60	PT-1/8			
JSFD-24040D	24	101	188	25	60	PT-1/8			
JSFD-25040D	25	105	192	25	60	PT-1/8			
JSFD-26040D	26	109	209	32	70	PT-1/4	WCMX050308R-PG	TSB-30070 (ZSB-30070)	TXL-8
JSFD-27040D	27	113	213	32	70	PT-1/4			
JSFD-28040D	28	117	214	32	70	PT-1/4			
JSFD-29040D	29	121	221	32	70	PT-1/4			
JSFD-30040D	30	125	225	32	70	PT-1/4			
JSFD-31040D	31	129	229	32	70	PT-1/4	WCMX06T308R-PG	TSB-35090 (ZSB-35090)	TXL-15
JSFD-32040D	32	133	233	32	70	PT-1/4			
JSFD-33040D	33	137	237	32	70	PT-1/4			
JSFD-34040D	34	141	241	32	70	PT-1/4			
JSFD-35040D	35	145	245	32	70	PT-1/4			
JSFD-36040D	36	149	249	32	70	PT-1/4	WCMX080412R-PG	TSB-40110 (ZSB-40110)	TXL-15
JSFD-37040D	37	153	253	32	70	PT-1/4			
JSFD-38040D	37	157	257	32	70	PT-1/4			
JSFD-39040D	39	161	261	32	70	PT-1/4			
JSFD-40040D	40	165	265	32	70	PT-1/4			
JSFD-41040D	41	169	269	32	70	PT-1/4	WCMX080412R-PG	TSB-40110 (ZSB-40110)	TXL-15
JSFD-42040D	42	173	283	40	80	PT-1/4			
JSFD-43040D	43	177	287	40	80	PT-1/4			
JSFD-44040D	44	181	291	40	80	PT-1/4			
JSFD-45040D	45	185	295	40	80	PT-1/4			
JSFD-46040D	46	189	299	40	80	PT-1/4	WCMX080412R-PG	TSB-40110 (ZSB-40110)	TXL-15
JSFD-47040D	47	193	303	40	80	PT-1/4			
JSFD-48040D	48	197	307	40	80	PT-1/4			
JSFD-49040D	49	201	311	40	80	PT-1/4			
JSFD-50040D	50	205	315	40	80	PT-1/4			
JSFD-51040D	51	209	319	40	80	PT-1/4	WCMX080412R-PG	TSB-40110 (ZSB-40110)	TXL-15
JSFD-52040D	52	213	323	40	80	PT-1/4			
JSFD-53040D	53	217	327	40	80	PT-1/4			
JSFD-54040D	54	221	331	40	80	PT-1/4			
JSFD-55040D	55	225	335	40	80	PT-1/4			
JSFD-56040D	56	229	339	40	80	PT-1/4	WCMX080412R-PG	TSB-40110 (ZSB-40110)	TXL-15
JSFD-57040D	57	233	343	40	80	PT-1/4			
JSFD-58040D	58	237	347	40	80	PT-1/4			

* TSB : Big screw head / ZSB : Small screw head

MILLING & DRILLING

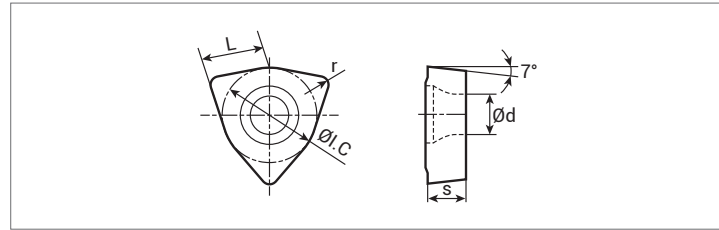

SPG200

- PVD Coating
- P20, M20

Insert shape	Type	Dimensions (mm)					Grade
		L	ØI.C	s	d	r	SPG200
	WCMX030208R-PG	3.8	5.56	2.38	2.8	0.8	●
	WCMX040208R-PG	4.3	6.35	2.38	3.1	0.8	●
	WCMX050308R-PG	5.4	7.94	3.18	3.2	0.8	●
	WCMX06T308R-PG	6.5	9.525	3.97	3.7	0.8	●
	WCMX080412R-PG	8.7	12.7	4.76	4.3	1.2	●

● Stock

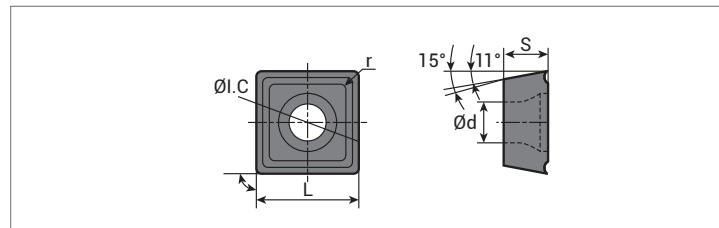

SPG207

- PVD Coating
- P20, M20

Insert shape	Type	Dimensions (mm)					Grade
		L	ØI.C	s	d	r	SPG200
	SPGT050204-PM	5.0	5.0	2.38	2.2	0.4	●
	SPGT060204-PM	6.0	6.0	2.38	2.6	0.4	●
	SPGT07T308-PM	7.94	7.94	3.97	2.8	0.8	●
	SPGT090408-PM	9.8	9.8	4.3	4.2	0.8	●
	SPGT110408-PM	11.5	11.5	4.76	4.4	0.8	●
	SPGT140512-PM	14.3	14.3	5.2	5.75	1.2	●

● Stock

MEMO

DRILLING

SPIDC 2D DRILL HOLDER

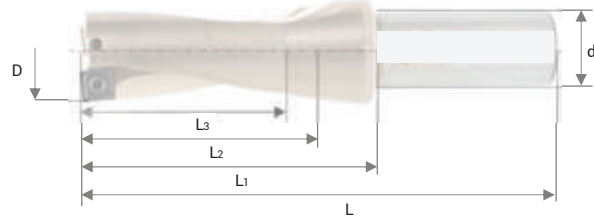

Designation	CP CODE	D	L	L ₁	L ₂	L ₃	d	Insert	Clamping screw	Wrench
SPIDC125-2D-S20-SP05	03080001	12.5	105	55	30	25	20	SPMG/SPGT 050204	M2.2X5	T6
SPIDC130-2D-S20-SP05	03080004	13	106	56	31	26				
SPIDC135-2D-S20-SP05	03080007	13.5	107	57	32	27				
SPIDC140-2D-S25-SP05	03080010	14	114	58	33	28				
SPIDC145-2D-S25-SP05	03080013	14.5	115	59	34	29				
SPIDC150-2D-S25-SP05	03080016	15	116	60	35	30				
SPIDC155-2D-S25-SP05	03080019	15.5	117	61	36	31				
SPIDC160-2D-S25-SP06	03080022	16	118	62	37	32				
SPIDC165-2D-S25-SP06	03080025	16.5	119	63	38	33				
SPIDC170-2D-S25-SP06	03080028	17	120	64	39	34				
SPIDC175-2D-S25-SP06	03080031	17.5	121	65	40	35	25	SPMG/SPGT 060204	M2.2X6	T7
SPIDC180-2D-S25-SP06	03080034	18	122	66	41	36				
SPIDC185-2D-S25-SP06	03080037	18.5	123	67	42	37				
SPIDC190-2D-S25-SP06	03080040	19	124	68	43	38				
SPIDC195-2D-S25-SP06	03080043	19.5	125	69	44	39				
SPIDC200-2D-S25-SP06	03080046	20	126	70	45	40				
SPIDC205-2D-S25-SP06	03080049	20.5	127	71	46	41				
SPIDC210-2D-S25-SP06	03080052	21	133	77	47	42				
SPIDC215-2D-S25-SP06	03080055	21.5	134	78	48	43				
SPIDC220-2D-S25-SP07	03080058	22	135	79	49	44				
SPIDC225-2D-S25-SP07	03080061	22.5	136	80	50	45	32	SPMG/SPGT 07T308	M2.5X6	T8
SPIDC230-2D-S25-SP07	03080064	23	137	81	51	46				
SPIDC235-2D-S25-SP07	03080067	23.5	138	82	52	47				
SPIDC240-2D-S25-SP07	03080070	24	139	83	53	48				
SPIDC245-2D-S25-SP07	03080073	24.5	140	84	54	49				
SPIDC250-2D-S25-SP07	03080076	25	141	85	55	50				
SPIDC255-2D-S32-SP07	03080079	25.5	146	86	56	51				
SPIDC260-2D-S32-SP07	03080082	26	147	87	57	52				
SPIDC265-2D-S32-SP07	03080085	26.5	147.5	88	58	53				
SPIDC270-2D-S32-SP07	03080088	27	149	89	59	54				
SPIDC275-2D-S32-SP07	03080091	27.5	150	90	61	55	32	SPMG/SPGT 090408	M3.5X10	T15
SPIDC280-2D-S32-SP09	03080094	28	151	91	61	56				
SPIDC285-2D-S32-SP09	03080097	28.5	152	92	62	57				
SPIDC290-2D-S32-SP09	03080100	29	153	93	63	58				
SPIDC295-2D-S32-SP09	03080103	29.5	154	94	64	59				
SPIDC300-2D-S32-SP09	03080106	30	155	95	65	60				

DRILLING

SPIDC 2D DRILL HOLDER



Designation	CP CODE	D	L	L ₁	L ₂	L ₃	d	Insert	Clamping screw	Wrench
SPIDC305-2D-S32-SP09	03080109	30.5	156	96	66	61	32	SPMG/SPGT 090408	M3.5X10	T15
SPIDC310-2D-S32-SP09	03080112	31	157	97	67	62				
SPIDC315-2D-S32-SP09	03080115	31.5	158	98	68	63				
SPIDC320-2D-S32-SP09	03080118	32	159	99	69	64				
SPIDC325-2D-S32-SP09	03080121	32.5	160	100	70	65				
SPIDC330-2D-S32-SP09	03080124	33	161	101	71	66				
SPIDC335-2D-S32-SP09	03080127	33.5	162	102	72	67				
SPIDC340-2D-S32-SP11	03080130	34	163	103	73	68				
SPIDC345-2D-S32-SP11	03080133	34.5	164	104	74	69				
SPIDC350-2D-S32-SP11	03080136	35	165	105	75	70				
SPIDC355-2D-S32-SP11	03080139	35.5	166	106	76	71	32	SPMG/SPGT 110408	M4X10	T15
SPIDC360-2D-S32-SP11	03080142	36	167	107	77	72				
SPIDC365-2D-S32-SP11	03080145	36.5	168	108	78	73				
SPIDC370-2D-S32-SP11	03080148	37	169	109	79	74				
SPIDC375-2D-S32-SP11	03080151	37.5	170	110	80	75				
SPIDC380-2D-S32-SP11	03080154	38	171	111	81	76				
SPIDC385-2D-S32-SP11	03080157	38.5	172	112	82	77				
SPIDC390-2D-S32-SP11	03080160	39	173	113	83	78				
SPIDC395-2D-S32-SP11	03080163	39.5	174	114	84	79				
SPIDC400-2D-S32-SP11	03080166	40	175	115	85	80				

DRILLING

SPIDC 3D DRILL HOLDER

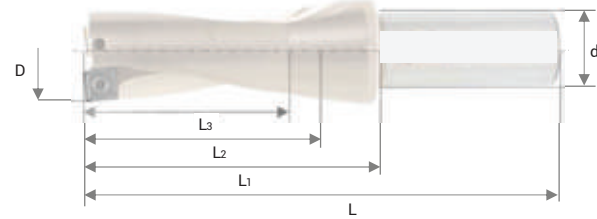

Designation	CP CODE	D	L	L ₁	L ₂	L ₃	d	Insert	Clamping screw	Wrench
SPIDC125-3D-S20-SP05	03080002	12.5	117.5	67.5	42.5	37.5	20	SPMG/SPGT 050204	M2.2X5	T6
SPIDC130-3D-S20-SP05	03080005	13	119	69	44	39				
SPIDC135-3D-S20-SP05	03080008	13.5	120.6	70.5	45.5	40.5				
SPIDC140-3D-S25-SP05	03080011	14	128	72	47	42				
SPIDC145-3D-S25-SP05	03080014	14.5	129.5	73.5	48.5	43.5				
SPIDC150-3D-S25-SP05	03080017	15	131	75	50	45				
SPIDC155-3D-S25-SP05	03080020	15.5	132.5	76.5	51.5	46.5				
SPIDC160-3D-S25-SP06	03080023	16	134	78	53	48				
SPIDC165-3D-S25-SP06	03080026	16.5	135.5	79.5	54.5	49.5				
SPIDC170-3D-S25-SP06	03080029	17	137	81	56	51				
SPIDC175-3D-S25-SP06	03080032	17.5	138.5	82.5	57.5	52.5	25	SPMG/SPGT 060204	M2.2X6	T7
SPIDC180-3D-S25-SP06	03080035	18	140	84	59	54				
SPIDC185-3D-S25-SP06	03080038	18.5	141.5	85.5	60.5	55.5				
SPIDC190-3D-S25-SP06	03080041	19	143	87	62	57				
SPIDC195-3D-S25-SP06	03080044	19.5	144.5	88.5	63.5	58.5				
SPIDC200-3D-S25-SP06	03080047	20	146	90	65	60				
SPIDC205-3D-S25-SP06	03080050	20.5	147.5	91.5	66.5	61.5				
SPIDC210-3D-S25-SP06	03080053	21	154	98	68	63				
SPIDC215-3D-S25-SP06	03080056	21.5	155.5	99.5	69.5	64.5				
SPIDC220-3D-S25-SP07	03080059	22	157	101	71	66				
SPIDC225-3D-S25-SP07	03080062	22.5	158.5	102.5	72.5	67.5	32	SPMG/SPGT 07T308	M2.5X6	T8
SPIDC230-3D-S25-SP07	03080065	23	160	104	74	69				
SPIDC235-3D-S25-SP07	03080068	23.5	161.5	105.5	75.5	70.5				
SPIDC240-3D-S25-SP07	03080071	24	163	107	77	72				
SPIDC245-3D-S25-SP07	03080074	24.5	164.5	108.5	78.5	73.5				
SPIDC250-3D-S25-SP07	03080077	25	166	110	80	75				
SPIDC255-3D-S32-SP07	03080080	25.5	171.5	111.5	81.5	76.5				
SPIDC260-3D-S32-SP07	03080083	26	173	113	83	78				
SPIDC265-3D-S32-SP07	03080086	26.5	174	114.5	84.5	79.5				
SPIDC270-3D-S32-SP07	03080089	27	176	116	86	81				
SPIDC275-3D-S32-SP07	03080092	27.5	177.5	117.5	87.5	82.5	32	SPMG/SPGT 090408	M3.5X10	T15
SPIDC280-3D-S32-SP09	03080095	28	179	119	89	84				
SPIDC285-3D-S32-SP09	03080098	28.5	180.5	120.5	90.5	85.5				
SPIDC290-3D-S32-SP09	03080101	29	182	122	92	87				
SPIDC295-3D-S32-SP09	03080104	29.5	183.5	123.5	93.5	88.5				
SPIDC300-3D-S32-SP09	03080107	30	185	125	95	90				

DRILLING

SPIDC 3D DRILL HOLDER



Designation	CP CODE	D	L	L ₁	L ₂	L ₃	d	Insert	Clamping screw	Wrench
SPIDC305-3D-S32-SP09	03080110	30.5	186.5	126.5	96.5	91.5	32	SPMG/SPGT 090408	M3.5X10	T15
SPIDC310-3D-S32-SP09	03080113	31	188	128	98	93				
SPIDC315-3D-S32-SP09	03080116	31.5	189.5	129.5	99.5	94.5				
SPIDC320-3D-S32-SP09	03080119	32	191	131	101	96				
SPIDC325-3D-S32-SP09	03080122	32.5	192.5	132.5	102.5	97.5				
SPIDC330-3D-S32-SP09	03080125	33	194	134	104	99				
SPIDC335-3D-S32-SP09	03080128	33.5	195.5	135.5	105.5	100.5				
SPIDC340-3D-S32-SP11	03080131	34	197	137	107	102				
SPIDC345-3D-S32-SP11	03080134	34.5	191.5	131.5	124.5	103.5				
SPIDC350-3D-S32-SP11	03080137	35	200	140	110	105				
SPIDC355-3D-S32-SP11	03080140	35.5	194.5	134.5	127.5	106.5	32	SPMG/SPGT 110408	M4X10	T15
SPIDC360-3D-S32-SP11	03080143	36	203	143	113	108				
SPIDC365-3D-S32-SP11	03080146	36.5	197.5	137.5	130.5	109.5				
SPIDC370-3D-S32-SP11	03080149	37	206	146	116	111				
SPIDC375-3D-S32-SP11	03080152	37.5	199.5	139.5	132.5	112.5				
SPIDC380-3D-S32-SP11	03080155	38	209	149	119	114				
SPIDC385-3D-S32-SP11	03080158	38.5	202.5	142.5	135.5	115.5				
SPIDC390-3D-S32-SP11	03080161	39	212	152	122	117				
SPIDC395-3D-S32-SP11	03080164	39.5	205.5	145.5	138.5	118.5				
SPIDC400-3D-S32-SP11	03080167	40	215	155	125	120				

DRILLING

WIDC 2D DRILL HOLDER

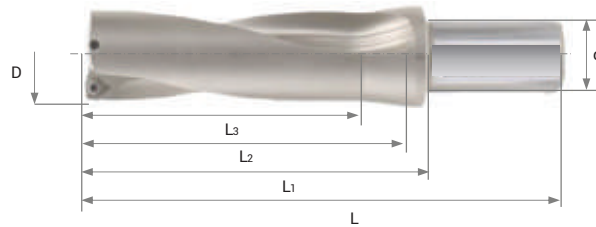

Designation	D	L	L ₁	L ₂	L ₃	d	Insert	Clamping screw	Wrench
WIDC140-2D-S25-WC03	14.0	109	53	46	28	25	WCGX 0302	M2.5X5	T7
WIDC145-2D-S25-WC03	14.5	110	54	47	29				
WIDC150-2D-S25-WC03	15.0	109	53	46	30				
WIDC155-2D-S25-WC03	15.5	110	54	47	31				
WIDC160-2D-S25-WC03	16.0	111	55	48	32				
WIDC165-2D-S25-WC03	16.5	112	56	49	33				
WIDC170-2D-S25-WC03	17.0	113	57	50	34				
WIDC175-2D-S25-WC03	17.5	114	58	51	35				
WIDC180-2D-S25-WC03	18.0	115	59	52	36				
WIDC185-2D-S25-WC03	18.5	119	60	53	37				
WIDC190-2D-S25-WC03	19.0	115	59	52	38				
WIDC195-2D-S25-WC03	19.5	116	60	53	39				
WIDC200-2D-S25-WC04	20.0	117.5	61.5	54.5	40				
WIDC205-2D-S25-WC04	20.5	119	63	56	41				
WIDC210-2D-S25-WC04	21.0	120	64	57	42				
WIDC215-2D-S25-WC04	21.5	121	65	58	43				
WIDC220-2D-S25-WC04	22.0	122	66	59	44				
WIDC225-2D-S25-WC04	22.5	123	67	60	45				
WIDC230-2D-S25-WC04	23.0	124	68	61	46				
WIDC235-2D-S25-WC04	23.5	125	69	62	47				
WIDC240-2D-S25-WC05	24.0	126	70	63	48				
WIDC245-2D-S25-WC05	24.5	127	71	64	49				
WIDC250-2D-S25-WC05	25.0	132	76	69	50				
WIDC255-2D-S32-WC05	25.5	137	77	70	51				
WIDC260-2D-S32-WC05	26.0	138	78	71	52				
WIDC265-2D-S32-WC05	26.5	139	79	72	53				
WIDC270-2D-S32-WC05	27.0	140	80	73	54				
WIDC275-2D-S32-WC05	27.5	141	81	74	55				
WIDC280-2D-S32-WC05	28.0	142	82	75	56				
WIDC285-2D-S32-WC05	28.5	143	83	76	57				
WIDC290-2D-S32-WC05	29.0	144	84	77	58				
WIDC295-2D-S32-WC05	29.5	145	85	78	59				
WIDC300-2D-S32-WC05	30.0	146	86	79	60				
WIDC305-2D-S32-WC05	30.5	146	86	79	61				
WIDC310-2D-S32-WC06	31.0	147	87	80	62				
WIDC315-2D-S32-WC06	31.5	148	88	81	63				
						32	WCGX 0503	M3.0X8	T8
							WCGX 06T3	M3.5X10	T15

DRILLING

WIDC 2D DRILL HOLDER



Designation	D	L	L ₁	L ₂	L ₃	d	Insert	Clamping screw	Wrench
WIDC320-2D-S32-WC06	32.0	149	89	82	64	32	WCGX 06T3	M3.5X10	T15
WIDC325-2D-S32-WC06	32.5	150	90	83	65				
WIDC330-2D-S32-WC06	33.0	151	91	84	66				
WIDC335-2D-S32-WC06	33.5	152	92	85	67				
WIDC340-2D-S32-WC06	34.0	152	92	85	68				
WIDC345-2D-S32-WC06	34.5	153	93	86	69				
WIDC350-2D-S32-WC06	35.0	155	95	88	70				
WIDC355-2D-S32-WC06	35.5	156	96	89	71				
WIDC360-2D-S32-WC06	36.0	157	97	90	72				
WIDC365-2D-S32-WC06	36.5	158	98	91	73				
WIDC370-2D-S32-WC06	37.0	159	99	92	74				
WIDC375-2D-S32-WC06	37.5	161	101	94	75				
WIDC380-2D-S32-WC06	38.0	158.5	98.5	91.5	76				
WIDC385-2D-S32-WC06	38.5	159.5	99.5	92.5	77				
WIDC390-2D-S32-WC06	39.0	158	98	91	78				
WIDC395-2D-S32-WC06	39.5	159.5	99.5	92.5	79				
WIDC400-2D-S32-WC06	40.0	159	99	92	80				

DRILLING

WIDC 3D DRILL HOLDER

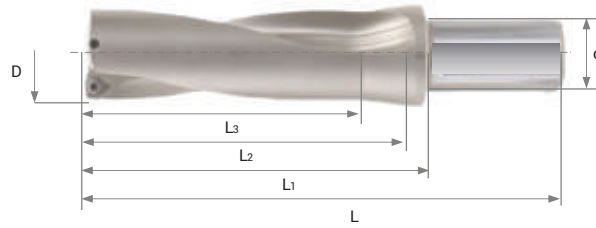

Designation	D	L	L ₁	L ₂	L ₃	d	Insert	Clamping screw	Wrench				
WIDC140-3D-S25-WC03	14.0	123	67	60	42	25	WCGX 0302	M2.5X5	T7				
WIDC145-3D-S25-WC03	14.5	124.5	68.5	61.5	43.5								
WIDC150-3D-S25-WC03	15.0	124	68	61	45								
WIDC155-3D-S25-WC03	15.5	125.5	69.5	62.5	46.5								
WIDC160-3D-S25-WC03	16.0	127	71	64	48								
WIDC165-3D-S25-WC03	16.5	128.5	72.5	65.5	49.5								
WIDC170-3D-S25-WC03	17.0	130	74	67	51								
WIDC175-3D-S25-WC03	175.5	131.5	75.5	68.5	52.5								
WIDC180-3D-S25-WC03	18.0	133	77	70	54								
WIDC185-3D-S25-WC03	18.5	134.5	78.5	71.5	55.5								
WIDC190-3D-S25-WC03	19.0	134	78	71	57								
WIDC195-3D-S25-WC03	19.5	135.5	79.5	72.5	58.5								
WIDC200-3D-S25-WC04	20.0	137.5	81.5	74.5	60								
WIDC205-3D-S25-WC04	20.5	139.5	83.5	76.5	61.5								
WIDC210-3D-S25-WC04	21.0	141	85	78	63								
WIDC215-3D-S25-WC04	21.5	142.5	86.5	79.5	64.5	32	WCGX 0402	M2.5X6	T8				
WIDC220-3D-S25-WC04	22.0	144	88	81	66								
WIDC225-3D-S25-WC04	22.5	145.5	89.5	82.5	67.5								
WIDC230-3D-S25-WC04	23.0	147	91	84	69								
WIDC235-3D-S25-WC04	23.5	148.5	92.5	85.5	70.5								
WIDC240-3D-S25-WC05	24.0	150	94	87	72								
WIDC245-3D-S25-WC05	24.5	151.5	95.5	88.5	73.5								
WIDC250-3D-S25-WC05	25.0	157	101	94	75								
WIDC255-3D-S32-WC05	25.5	162.5	103	95.5	76.5								
WIDC260-3D-S32-WC05	26.0	164	104	97	78								
WIDC265-3D-S32-WC05	26.5	165.5	106	98.5	79.5								
WIDC270-3D-S32-WC05	27.0	167	107	100	81								
WIDC275-3D-S32-WC05	27.5	168.5	109	102	82.5								
WIDC280-3D-S32-WC05	28.0	170	110	103	84								
WIDC285-3D-S32-WC05	28.5	171.5	112	105	85.5								
WIDC290-3D-S32-WC05	29.0	173	113	106	87	32	WCGX 0503	M3.0X8	T15				
WIDC295-3D-S32-WC05	29.5	174.5	115	108	88.5								
WIDC300-3D-S32-WC05	30.0	176	116	109	90								
WIDC305-3D-S32-WC05	30.5	176.5	117	110	91.5								
WIDC310-3D-S32-WC06	31.0	178	118	111	93								
WIDC315-3D-S32-WC06	31.5	179.5	120	113	94.5								
WIDC320-3D-S32-WC06	32.0	181	121	114	96					32	WCGX 06T3	M3.5X10	T15
WIDC325-3D-S32-WC06	32.5	182.5	123	116	97.5								
WIDC330-3D-S32-WC06	33.0	184	124	117	99								
WIDC335-3D-S32-WC06	33.5	185.5	126	119	101								
WIDC340-3D-S32-WC06	34.0	186	126	119	102								
WIDC345-3D-S32-WC06	34.5	187.5	128	121	104								
WIDC350-3D-S32-WC06	35.0	190	130	123	105								
WIDC355-3D-S32-WC06	35.5	191.5	132	125	107								
WIDC360-3D-S32-WC06	36.0	193	133	126	108								
WIDC365-3D-S32-WC06	36.5	194.5	135	128	110								
WIDC370-3D-S32-WC06	37.0	196	136	129	111								
WIDC375-3D-S32-WC06	37.5	198.5	139	132	113								
WIDC380-3D-S32-WC06	38.0	196.5	139	130	114								
WIDC385-3D-S32-WC06	38.5	198	137	131	116								
WIDC390-3D-S32-WC06	39.0	197	138	130	117								
WIDC395-3D-S32-WC06	39.5	199	137	132	119								
WIDC400-3D-S32-WC06	40.0	199	139	132	120								

TURNING & MILLING

CERAMIC

CERMET

PCBN / PCD

TOOL HOLDER

MILLING CUTTER

DRILLING

WIDC 3D DRILL HOLDER



Designation	D	L	L ₁	L ₂	L ₃	d	Insert	Clamping screw	Wrench
WIDC320-3D-S32-WC06	32.0	181	121	114	96	32	WCGX 06T3	M3.5X10	T15
WIDC325-3D-S32-WC06	32.5	182.5	123	116	97.5				
WIDC330-3D-S32-WC06	33.0	184	124	117	99				
WIDC335-3D-S32-WC06	33.5	185.5	126	119	101				
WIDC340-3D-S32-WC06	34.0	186	126	119	102				
WIDC345-3D-S32-WC06	34.5	187.5	128	121	104				
WIDC350-3D-S32-WC06	35.0	190	130	123	105				
WIDC355-3D-S32-WC06	35.5	191.5	132	125	107				
WIDC360-3D-S32-WC06	36.0	193	133	126	108				
WIDC365-3D-S32-WC06	36.5	194.5	135	128	110				
WIDC370-3D-S32-WC06	37.0	196	136	129	111				
WIDC375-3D-S32-WC06	37.5	198.5	139	132	113				
WIDC380-3D-S32-WC06	38.0	196.5	139	130	114				
WIDC385-3D-S32-WC06	38.5	198	137	131	116				
WIDC390-3D-S32-WC06	39.0	197	138	130	117				
WIDC395-3D-S32-WC06	39.5	199	137	132	119				
WIDC400-3D-S32-WC06	40.0	199	139	132	120				

TURNING & MILLING

CERAMIC

CERMET

PCBN / PCD

TOOL HOLDER

MILLING CUTTER

TECHNICAL DATA

Test Results	A 296
Trouble Shooting	A 299
Hardness Conversion Table	A 300
Grade Comparison	A 302
Comparison of Work-piece	A 303



TECHNICAL DATA

HIGH TEMPERATURE STRENGTH

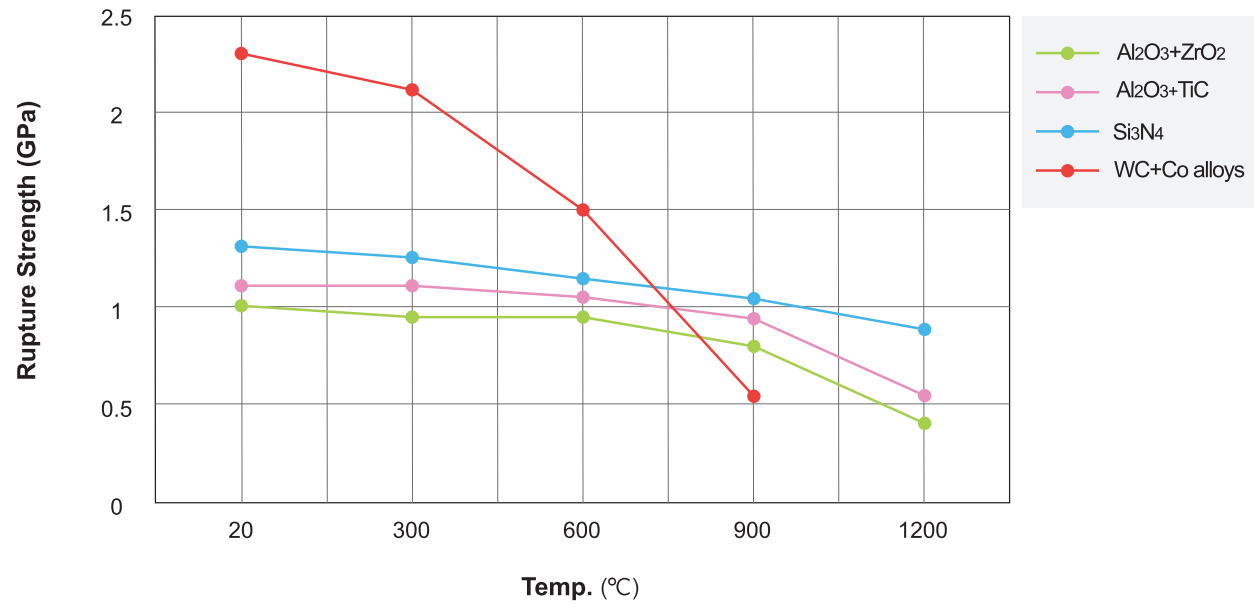

FLANK WEAR VS CUTTING DISTANCE

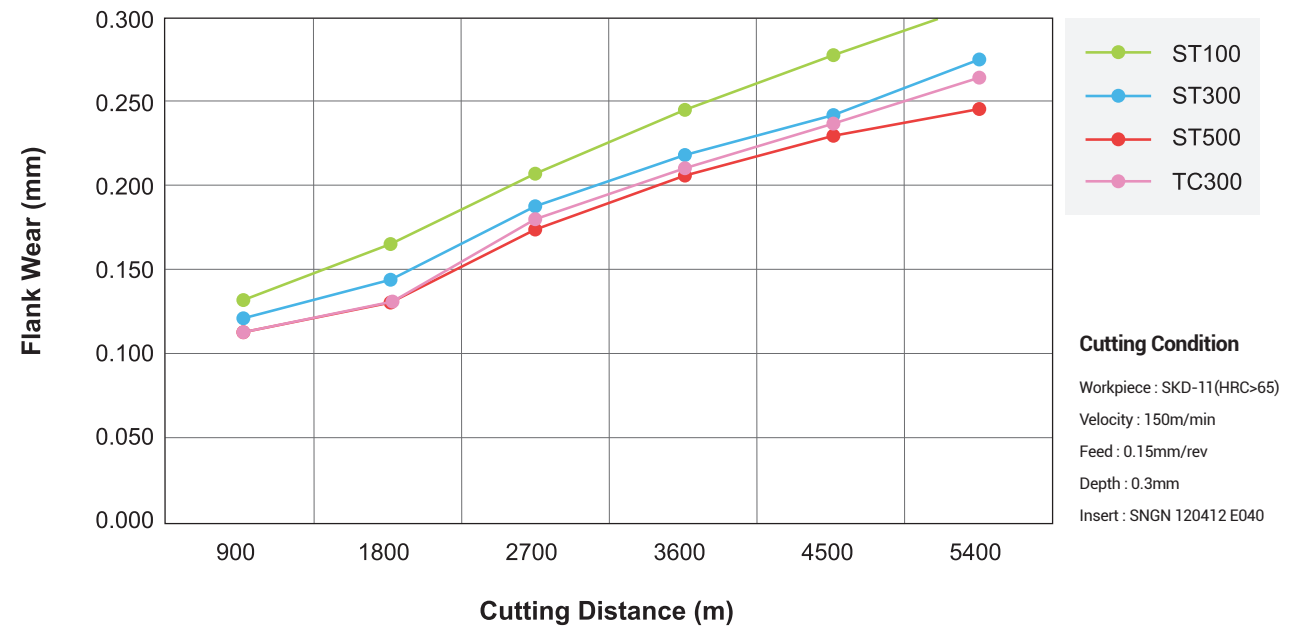

HARDNESS VS TEMPERATURE

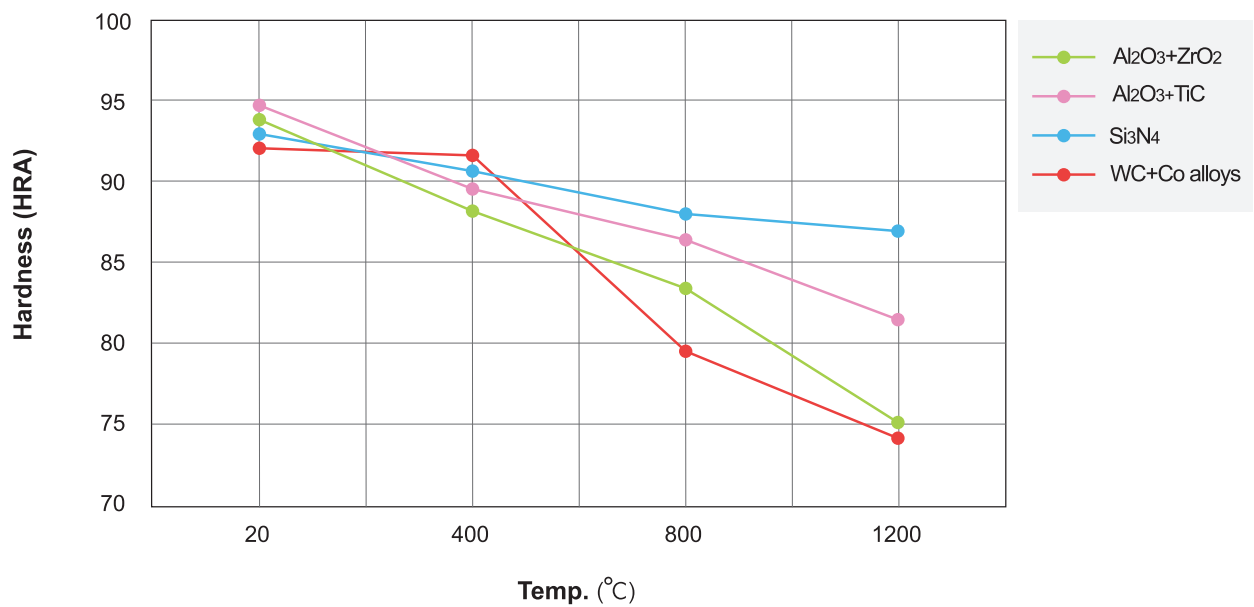

FLANK WEAR VS CUTTING DISTANCE

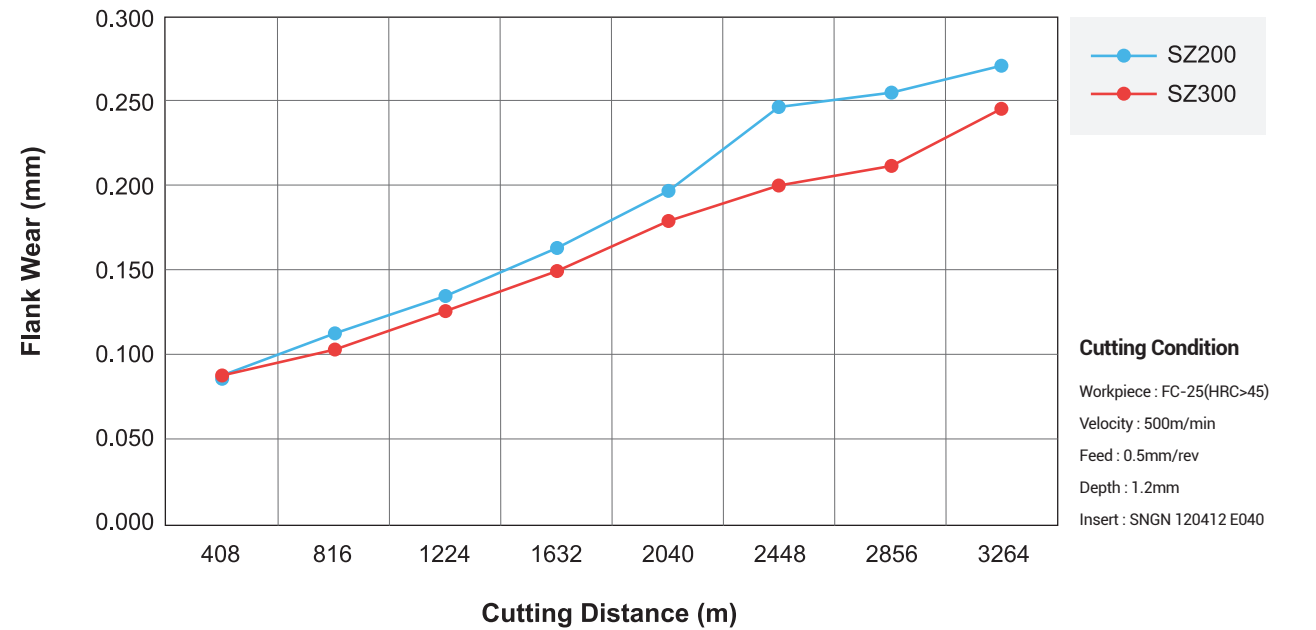

TECHNICAL DATA

FLANK WEAR VS CUTTING DISTANCE

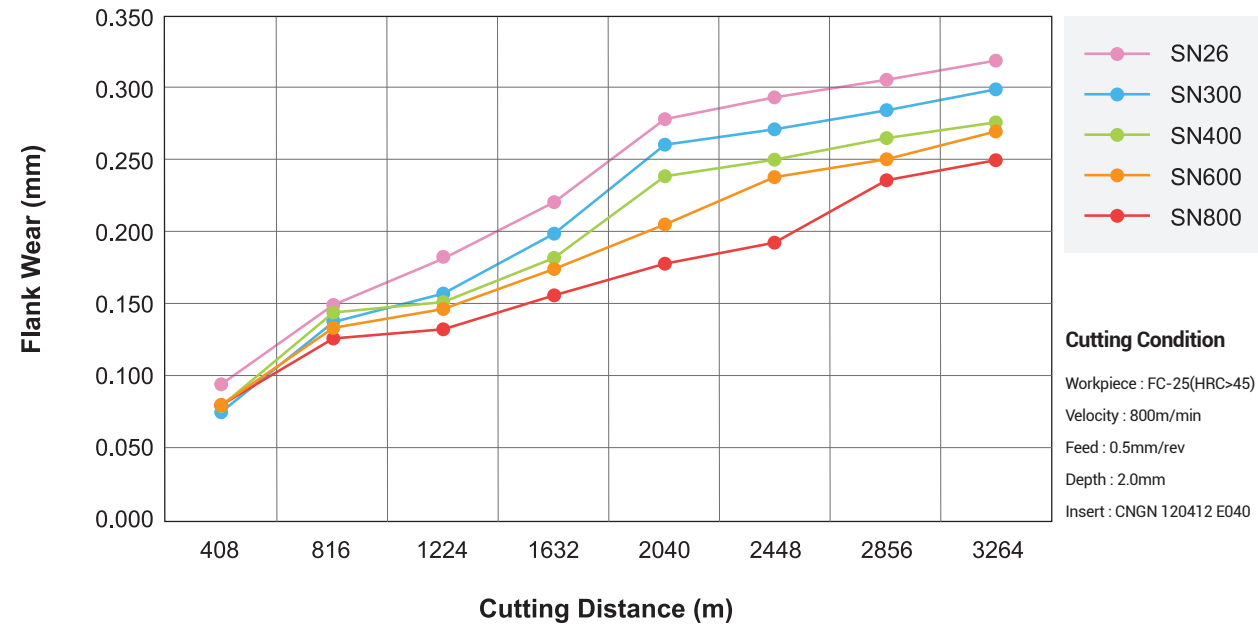

FLANK WEAR VS CUTTING DISTANCE

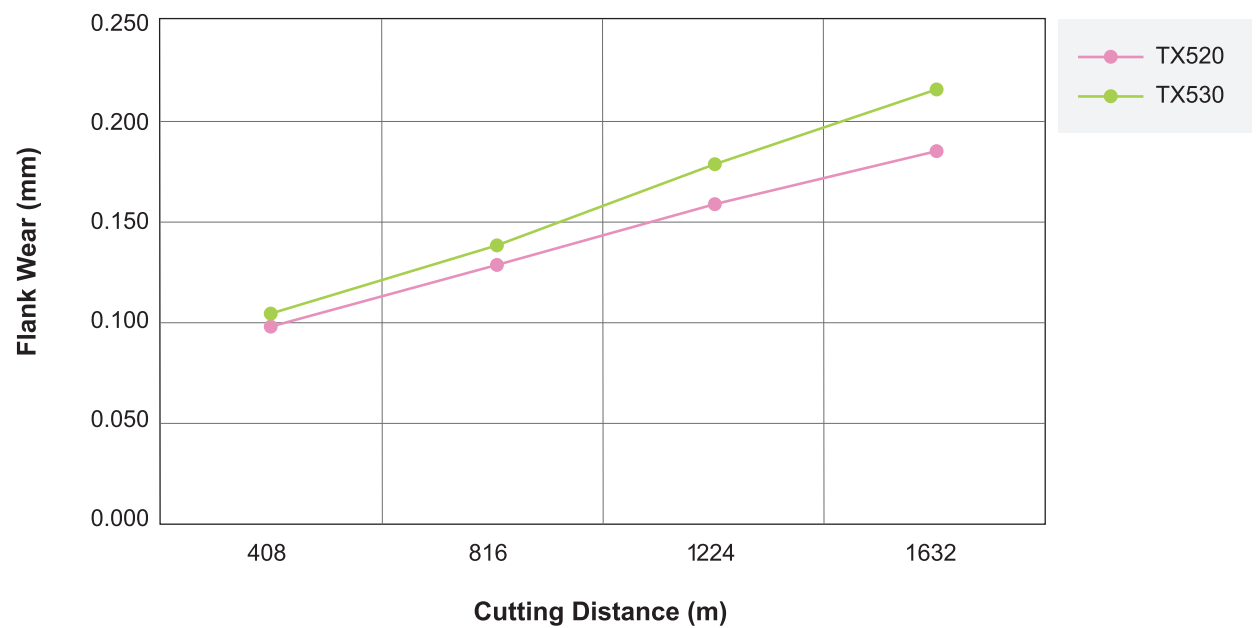

TROUBLE SHOOTING

Types	Status	Cause	Countermeasures
Flank Wear	<ul style="list-style-type: none"> Variation of dimension Deteriorated finishing surface Increasing machining load 	<ul style="list-style-type: none"> Wear by grinded surface Excessive feed rate and cutting speed 	<ul style="list-style-type: none"> Reduce cutting Speed Use larger corner radius Use high wear-resistant grade
Crater Wear	<ul style="list-style-type: none"> Deterioration of chip disposal Deteriorated finishing surface 	<ul style="list-style-type: none"> Wear by chips (remarkable with ductile cast iron) Excessive cutting speed 	<ul style="list-style-type: none"> Reduce cutting Speed Use smaller lead angle Check edge geometry Use high wear-resistant grade
Thermal Cracking	<ul style="list-style-type: none"> Deteriorated finishing surface Occurrence of chipping 	<ul style="list-style-type: none"> Severe cycle of heating & cooling during cutting Excessive feed rate and cutting speed 	<ul style="list-style-type: none"> Reduce cutting speed Reduce feed rate Change to dry machining Use tougher grade
Notch Wear	<ul style="list-style-type: none"> Deteriorated finishing surface Increasing machining load 	<ul style="list-style-type: none"> Excessive feed rate and cutting depth 	<ul style="list-style-type: none"> Reduce cutting depth Reduce feed rate Use tougher grade Increase coolant supply
Edge Splintering	<ul style="list-style-type: none"> Occurrence of fire flower Occurrence of noise Increasing Machining load 	<ul style="list-style-type: none"> Excessive feed rate Falling-off of BUE Weak cutting edge 	<ul style="list-style-type: none"> Use tougher grade Check edge geometry Increase stability of the system Use larger lead angle
Plastic Deformation	<ul style="list-style-type: none"> Variation of dimension Chipping of cutting edge 	<ul style="list-style-type: none"> High machining load Use of improper grade 	<ul style="list-style-type: none"> Reduce cutting speed Reduce feed rate Reduce cutting depth Use harder grade
Built-up-Edge	<ul style="list-style-type: none"> Deteriorated finishing surface Variation of dimension Occurrence of chipping 	<ul style="list-style-type: none"> High affinity with work piece Low cutting speed 	<ul style="list-style-type: none"> Increase cutting speed Increase feed rate Use tougher grade Use larger rake angle
Breakage	<ul style="list-style-type: none"> Occurrence of fire flower Cutting impossible 	<ul style="list-style-type: none"> Using low toughness Insert Using improper clamping holder 	<ul style="list-style-type: none"> Use tougher grade Reduce feed rate Reduce cutting depth Increase stability of the system

HARDNESS CONVERSION TABLE

VICKERS HARDNESS NUMBER (HV)	KNOOP HARDNESS NUMBER (HK)	BRINELL HARDNESS NUMBER (HB)		ROCKWELL HARDNESS NUMBER (HR)			ROCKWELL SUPERFICIAL HARDNESS NUMBER (HR)			SHORE HARDNESS NUMBER (HS)	TENSILE STRENGTH (APPROX.)	
		HBS 3000kgf LOAD 10mm STEEL BALL	HBW 3000kgf LOAD 10mm CARBIDE BALL	SCALE A 60kgf LOAD DIAMOND INDENTER	SCALE B 100kgf LOAD 1/16 STEEL BALL	SCALE C 150kgf LOAD DIAMOND INDENTER	SCALE D 100kgf LOAD DIAMOND INDENTER	SCALE 15N 15kgf LOAD DIAMOND INDENTER	SCALE 30N 30kgf LOAD DIAMOND INDENTER			SCALE 45N 45kgf LOAD DIAMOND INDENTER
1865				92.1		80	86.5	96.5	92.0	87.0		
1787				91.6		79	85.7	96.3	91.5	86.2		
1710				91.1		78	84.9	96.1	90.9	85.4		
1633				90.6		77	84.2	95.8	90.3	84.5		
1556				90.1		76	83.4	95.5	89.7	83.6		
1478				89.6		75	82.6	95.2	89.1	82.5		
1400				89.0		74	81.8	94.9	88.5	81.6		
1323				88.5		73	81.0	94.6	87.9	80.7		
1245				88.0		72	80.1	94.3	87.2	79.7		
1160				87.1		71	79.4	94.0	86.5	78.7		
1076	972			86.8		70	78.6	93.7	85.8	77.6		
1004	946			86.2		69	77.8	93.4	85.1	76.4		
940	920			85.6		68	76.9	93.2	84.3	75.4		
900	895			85.0		67	76.1	92.9	83.6	74.2	95.2	
865	870			84.5		66	75.4	92.5	82.8	73.3	93.1	
832	846		739	83.9		65	74.5	92.2	81.9	72.0	91.0	
800	822		722	83.4		64	73.8	91.8	81.1	71.0	88.9	
772	799		705	82.8		63	73.0	91.4	80.1	69.9	87.0	
746	776		688	82.3		62	72.2	91.1	79.3	66.6	85.2	
720	754		670	81.8		61	71.5	90.7	78.4	67.7	83.3	
697	732		654	81.2		60	70.7	90.2	77.5	66.6	81.6	
674	710		634	80.7		59	69.9	89.8	76.6	65.5	79.9	
653	690		615	80.1		58	69.2	89.3	75.7	64.3	78.2	
633	670		595	79.6		57	68.5	88.9	74.8	63.2	75.6	
613	650		577	79.0		56	67.7	88.3	73.9	62.0	75.0	
595	630		560	78.5		55	66.9	87.9	73.0	60.9	73.5	212
577	612		543	78.0		54	66.1	87.4	72.0	59.8	71.9	205
560	594		525	77.4		53	65.4	86.9	71.2	58.6	70.4	199
544	576	500	512	76.8		52	64.6	86.4	70.2	57.4	69.0	192
528	558	487	496	76.3		51	63.8	85.9	69.4	56.1	67.6	186
513	542	475	481	75.9		50	63.1	85.5	68.5	55.0	66.2	179
498	526	464	469	75.2		49	62.1	85.0	67.6	53.8	64.7	172
484	510	451	455	74.7		48	61.4	84.5	66.7	52.5	63.4	167
471	495	442	443	74.1		47	60.8	83.9	65.8	51.4	62.1	161
458	480	432	432	73.6		46	60.0	83.5	64.8	50.3	60.8	156
446	466	421	421	73.1		45	59.2	83.0	64.0	49.0	59.6	151
434	452	409	409	72.5		44	58.5	82.5	63.1	47.8	58.4	146
423	438	400	400	70.0		43	57.7	82.0	62.2	46.7	57.2	141
412	426	390	390	71.5		42	56.9	81.5	61.3	45.5	56.1	136
402	414	381	381	70.9		41	56.2	80.9	60.4	44.3	55.0	132
392	402	371	371	70.4		40	55.4	80.4	59.5	43.1	53.9	127
382	391	362	362	69.9		39	54.6	79.9	58.6	41.9	52.9	124
372	380	353	353	69.4		38	53.8	79.4	57.7	40.8	51.8	120
363	370	344	344	68.9		37	53.1	78.8	56.8	39.6	50.7	118
354	360	336	336	68.4	109.0	36	52.3	78.3	55.9	38.4	49.7	114
345	351	327	327	67.9	108.5	35	51.5	77.7	55.0	37.2	48.7	110

VICKERS HARDNESS NUMBER (HV)	KNOOP HARDNESS NUMBER (HK)	BRINELL HARDNESS NUMBER (HB)		ROCKWELL HARDNESS NUMBER (HR)			ROCKWELL SUPERFICIAL HARDNESS NUMBER (HR)			SHORE HARDNESS NUMBER (HS)	TENSILE STRENGTH (APPROX.)	
		HBS 3000kgf LOAD 10mm STEEL BALL	HBW 3000kgf LOAD 10mm CARBIDE BALL	SCALE A 60kgf LOAD DIAMOND INDENTER	SCALE B 100kgf LOAD 1/16 STEEL BALL	SCALE C 150kgf LOAD DIAMOND INDENTER	SCALE D 100kgf LOAD DIAMOND INDENTER	SCALE 15N 15kgf LOAD DIAMOND INDENTER	SCALE 30N 30kgf LOAD DIAMOND INDENTER			SCALE 45N 45kgf LOAD DIAMOND INDENTER
336	342	319	319	67.4	108.0	34	50.8	77.2	54.2	36.1	47.7	108
327	334	311	311	66.8	107.5	33	50.0	76.6	53.3	34.9	46.6	105
318	326	301	301	66.3	107.0	32	49.2	76.1	52.1	33.7	45.6	102
310	318	294	294	65.8	106.0	31	48.4	75.6	51.3	32.5	44.6	100
302	311	286	286	65.3	105.5	30	47.7	75.0	50.4	31.3	43.6	97
294	304	279	279	64.7	104.5	29	47.0	74.5	49.5	30.1	42.7	95
286	297	271	271	64.3	104.0	28	46.1	73.9	48.6	28.9	41.7	93
279	290	264	264	63.8	103.0	27	45.2	73.3	47.7	27.8	40.8	90
272	284	258	258	63.3	102.5	26	44.6	72.8	46.8	26.7	39.9	88
266	278	253	253	62.8	101.5	25	43.8	72.2	45.9	25.5	39.2	86
260	272	247	247	62.4	101.0	24	43.1	71.6	45.0	24.3	38.4	84
254	266	243	243	62.0	100.0	23	42.1	71.0	44.0	23.1	37.7	82
248	261	237	237	61.5	99.0	22	41.6	70.5	43.2	22.0	36.9	80
243	256	231	231	61.0	98.5	21	40.9	69.9	42.3	20.7	36.3	79
238	251	226	226	60.5	97.8	20	40.1	69.4	41.5	19.6	35.6	77
230	243	219	219		96.7	18					34.6	75
222	236	212	212		95.5	16					33.5	72
213	229	203	203		93.9	14					32.3	69
204	220	194	194		92.3	12					31.1	66
196	212	187	187		90.7	10					30.0	63
188	204	179	179		89.5	8						61
180	196	171	171		87.1	6						59
173	189	165	165		85.5	4						56
166	181	158	158		83.5	2						54

PROPERTIES OF ELEMENTS

Element	Density (g/cm ³)	Hardness (kg/mm ²)	Young's Modulus (X10 ³ kg/mm ²)	Thermal Expansion Coefficient (10 ⁻⁶ /°C)	Melting Point (°C)
WC	15.60	2,150	70	5.1	2,900
TiC	4.94	3,200	46	7.6	3,200
TaC	14.50	1,800	29	6.6	3,800
NbC	8.20	2,050	35	6.8	3,500
TiN	5.43	2,000	26	9.2	2,950
Al2O3	3.98	3,000	42	8.5	2,050
CBN	3.48	4,500	71	4.7	
Diamond	3.52 >	9,000	99	3.1	
Co	8.90		10~18	12.3	1,495
Ni	8.90		20	13.3	1,455

COMPARISON OF WORK-PIECE

ISO	Korea KS	United Kingdom BS	America AIS/SAE	German DIN	Spain UNF	Italy UNI	Sweden SS	France AFNOR	Japan JIS
	STS301	-	301	X9CrNi18-8	F.3517	X12CrNi17 07	2331	Z12CN17.07	SUS301
	STS303	303S21	303	X8CrNiS18-9	F.3508	X10CrNiS18.09	2346	Z10CNF18.09	SUS303
	STS304	304S31	304	-	F.3504 F.3541	X5CrNi18 10	2332/2333	Z6CN18.09	SUS304
	STS304	304S15	304	X5CrNi18-10	F.3551	X5CrNi18 10	2332	Z6CN18.09	SUS304
	-	304S11:12	304L	X2CrNi19-11	-	X2CrNi18 11	2352	-	-
	-	304S13	316L	X2CrNiMo17-12-2	-	X2CrNiMo17 12	2348	Z2CND17.12	-
SSC16, STS316L	304S13	304S13	316L	X2CrNiMo18-14-3	-	X2CrNiMo17 12	2353	Z2CND17.12	SCS16, SUS316L
SSC17	301S21	308	308	X2CrNiMoN17-11-2	F.8414	-	2370	Z1NCDU25.20	SCS17
STS304LN	304S62	304LN	304LN	X2CrNi18-10	-	-	2371	Z2CN18.10	SUS304LN
-	401S45	HW3	HW3	X45CrS9-3-1	F322	X45CrSi8	-	Z45CS9	SUH1
-	443S65	HNW6	HNW6	X85CrMoV18-2	F320B	X80CrSiNi20	-	Z80CSN20.02	SUH4
STR309	309S24	309	309	X15CrNiSi20-12	-	-	-	Z15CSN20.12	SUH309
STR310	310S24	310S	310S	X12CrNi2521	F.331	X60CrNi25.20	2361	Z12CN25 20	SUH310
-	312S54	-	-	X1CrNiMoCuN20-18-7	-	-	2378	Z1CNDU20-18-06AZ	-
-	316S33	316	316	X3CrNiMo17-3-3	-	X8CrNiMo17.13	2343, 2347	Z6CND18-12-03	-
STS316	316S16	316	316	X5CrNiMo17-2-2	F.3543	X5CrNiMo17.12	2347	Z6CND17.11	SUS316
STS316LN	-	316LN	316LN	X2CrNiMoN17-13-3	-	-	2375	Z2CND1713	SUS316LN
STS316L	-	316L	316L	X2CrNiMo1812	-	-	-	-	SUS316LN
STS416	416S21	416	416	X12CrS13	F.3411	X12CrS13	2380	Z11CF13	SUS416
-	320S17	316Ti	316Ti	X6CrNiMoTi17-12-2	F.3535	X6CrNiMoTi17 12	2350	Z6VDT17.12	-
STS317L	317S12	317L	317L	X24CrNiMo18-15-4	-	X2CrNiMo1816	2367	Z2CND19.15	SUS317L
-	-	318	318	X10CrNiMoNb18-12	-	X6CrNiMoNb17 13	-	Z6CNDNb17 13B	-
-	-	S32304	S32304	"X2CrNiN,234"	-	-	2327	Z2CN23-04AZ	-
-	-	S32900	S32900	X8CrNiMo.275	-	-	2324	-	-
-	-	S31803	S31803	X2CrNiMoN	-	-	2377	Z2CND22-0503	-
STS321	351S12	321	321	X10CrNiTi	F.3553 F.3523	X6CrNiTi18.11	2337	Z6CNT18.10	SUS321
STS347	347S17	347	347	X6CrNiNb18-10	F.3552 F.3524	X6CrNiNb18.11	2338	Z6CNNb18.10	SUS347
STS12	BA2	A2	A2	Z100CnMoV51	Z100CnMoV51	Z100CnMoV51KU	2260	Z100CDV5	SKD12
STS403	403S17	403	403	X6Cr13	F.3110	X6Cr13	2301	Z6C13	SUS403
STS405	403S17	405	405	X10CrAl13	F.3110	X10CrAl13	-	Z10C13	SUS405
STS410	410S21	410	410	X10Cr13	F.3401	X12Cr13	2302	Z10C14	SUS410
STS420J2	420S45	-	-	X46Cr13	F.3405	X40Cr145	2304	Z4CM	SUS420J2
STS430	430S15	430	430	X10CrAl18	F.3113	X8Cr17	-	Z10CAS18	SUS430
STS430	430S15	430	430	X6CrAl17	F.3113	X8Cr17	2320	ZBC17	SUS430
STS430F	-	430F	430F	X14CrMoS17	F.3117	X10CrS17	2383	Z10CF17	SUS430F
STS431	431S29	431	431	X22CrNi6	F.3427	X16CrNi16	2321	Z15CNi6.02	SUS431
STS434	434S17	434	434	X6CrMo17-1	-	X8CrMo17	2325	ZBCD17.01	SUS434
SSC5	425C11	CA6-NM	CA6-NM	X3CrNiMo13-4	-	(G)X6CrNi304	2385	Z4CND13.4M	SCS5
STR35,STR36	349S54	EV8	EV8	X53CrMnNiN21-9	-	X53CrMnNiN21,09	-	Z52CMN21.09	SUH35,SUH36
STR446	-	446	446	X10CrA2-4	-	X16Cr26	2322	Z10CAS24	SUH446
HRHC15	330C11	-	-	G-X40NiCrSi36-18	-	XG50NiCr39 19	-	-	SCH15
STR330	-	330	330	X12NiCrSi36-16	F.3313	-	-	Z12NCS35.16	SUH330
-	3072-76	4676	4676	NiCu30Al	-	-	-	-	-
-	-	5390A	5390A	-	-	-	-	NC22FeD	-
-	Mar-46	5391	5391	S-NiCr13A16MoNb	-	-	-	NC12D	-
-	HR8	5383	5383	NiCr19Fe19NbMo	-	-	-	NC19iNB	-
-	-	5537C	5537C	CoCr20W15Ni	-	-	-	KC20WN	-
-	-	5660	5660	NiFe35Cr14MoTi	-	-	-	ZSNCDT42	-
-	-	5666	5666	NiCr22Mo9Nb	-	-	-	NC22FeDNB	-
-	-	AMS5397	AMS5397	NiCr15Cr10MoATi	-	-	-	-	-
-	-	AMS5399	AMS5399	NiCr19Co11MoTi	-	-	-	NC19KDT	-
-	-	AMS5544	AMS5544	NiCr19Fe19NbMo	-	-	-	NC20K14	-
-	-	AMS5772	AMS5772	CoCr22W14Ni	-	-	-	KC22WN	-
-	TA10-13/TA28	AMSR56400	AMSR56400	TiAl6V4	-	-	-	T-AGV	-
-	YA14/17	AMSR54520	AMSR54520	TiAl5Sn2.5	-	-	-	T-A5E	-

COMPARISON OF WORK-PIECE

ISO	Korea KS	United Kingdom BS	America AIS/SAE	German DIN	Spain UNF	Italy UNI	Sweden SS	France AFNOR	Japan JIS
	Gray cast iron								
	GC100	-	No20B	GG10	-	FG10	0110	F110D	FC100
	GC150	Grade150	No25B	GG15	-	FG15	0115	F115D	FC150
	GC200	Grade220	No30B	GG20	-	-	0120	F120D	FC200
	GC250	Grade260	No35B	GG25	-	FG25	0125	F125D	FC250
	GC300	Grade300	GN045B	GG30	-	FG30	0130	F130D	FC300
	GC350	Grade350	No50B	GG35	-	FG35	0135	F135D	FC350
	-	Grade400	No55B	-	-	-	0140	F140D	-
	Ductile cast iron								
	GCD400	SNG420/12	60-40-18	GGG40	FGE 38-17	GS370-12	0717-02	FCS400-12	FCD400
	GCD500	SNG500/7	80-55-06	GGG50	FGE 50-7	GS500	0727	FGS500-7	FCD500
	GCD600	SNG600/3	-	GGG60	-	-	0732-03	FGS600-3	FCD600
	GCD700	SNG700/2	100-70-03	GGG70	FGS 70-2	GS700-2	0737-01	FGS700-2	FCD700
K Cast iron	-	Grade S6	A43D2	XNiCr20-2	-	-	0776	S-NC 202	-
	-	8 290/6	-	-	-	-	0814	MN 32-8	FCMB310
	-	B340/12	32510	GTS-35	-	-	0815	MN35-10	FCMW330
	-	P440/7	40010	GTS-45	-	GMN 45	0852	MN450	FCMW370
	-	P510/4	50005	GTS-55	-	GMN 55	0854	MP50-5	FCMP490
	-	P570/3	70003	-	-	-	0858	MP60-3	FCMP540
	-	P570/3	A220-70003	GTS-65	-	GMN 65	0856	MN 650-3	FCMP590
	-	P690/2	A220-80002	GTS-70	-	GMN 70	0862	MN700-2	FCMP690
	Aluminium alloy								
	-	1080(1A)	-	A199.90	-	-	-	1080A	A1080
	-	1050(1B)	1050	A199.50	-	-	-	1050A	A1050
	-	NS4	5052	AlMg2.5	-	-	-	5052	A5052
	-	NB6	5056	AlMg5	-	-	-	-	A5056
	-	NG61	5456	-	-	-	-	5957	A5556
	-	-	2036	AlCu2.5Mg0.5	-	-	-	2117	A2117
	-	HF15	-	AlCuMg1	-	-	-	2017S	A2017
	-	-	2124	AlCuMg2	-	-	-	2024	A2024

TECHNICAL DATA

COMPARISON OF WORK-PIECE (NI-BASED HEAT RESISTANT ALLOYS)

Material Condition	Commercial designation	Hardness Brinell HB		Nominal composition Approximate content in %										
		Ann.	Aged	Ni	Cr	Co	Fe	Mo	C	Mn	Si	Al	Ti	Others
Aged or Solution Treated and Aged	Astrolly	-	-	56.9	15	15	-	5.25	0.06	-	-	4	3.5	0.05
	Hastelloy R235	-	-	61	15	2.5	10	5.5	0.15	0.25	0.6	3	2	-
	AerMet 100	-	-	11.1	3.1	13.4	70	1.2	0.23	-	-	-	0.05	-
	Incoloy 901	180	300	44.3	12.5	-	34	6	0.05	0.24	0.12	0.15	2.7	0.15
	Incoloy 903	-	380	39	-	15	41	-	0.02	-	-	0.7	1.4	3
	Incoloy 909	-	-	38	-	13	42	1.25	-	-	0.4	0	1.5	4.7
	Incoloy MA 956	-	-	-	20	-	74	-	-	-	-	4.5	0.5	0.5
	Inconel 700	-	350	46	15	23.5	0.7	3.75	0.12	0.1	0.3	3	2.2	-
	Inconel 702	-	-	79.6	15.6	-	0.35	-	0.04	0.05	0.2	3	0.7	-
	Inconel 706	-	-	42	16	-	40	-	0.03	0.2	0.3	0.4	1.75	-
	Inconel 713	-	-	75	12.5	-	-	4.2	0.12	-	-	6.1	0.8	-
	Inconel 718	180	380	52.5	19	-	19	3	0.04	0.35	0.35	0.9	0.9	0.1
	Inconel 718 SPF	-	-	54	18	-	18.5	3	-	-	-	-	1	5
	Inconel 722	-	380	74.8	15	-	6.5	-	0.04	0.55	0.2	0.6	2.4	-
	Inconel X-750	-	390	73	15.5	-	7	-	0.04	0.35	0.35	0.7	2.5	-
	Inconel 751	-	-	70	15.5	-	7	-	0.1	1	0.5	1.5	2.6	0.5
	Jethete M-152	-	-	2.5	16.8	-	-	1.8	0.12	0.7	0.18	-	-	0.6
	Jethete M-252	-	320	55.3	20	10	-	10	0.15	0.5	0.5	1	2.6	-
	MAR-M 246	-	270	59.5	9	10	0.2	2.5	0.15	-	-	5.5	1.5	11.5
	MAR-M 421	-	-	62.3	15.5	10	-	1.7	0.15	-	-	4.3	1.75	5.3
	MAR-M 432	-	-	52.3	15.5	20	-	-	0.15	-	-	2.8	4.3	5
	Monel K-500	120	290	64	-	-	1	-	0.13	0.8	-	2.8	0.6	30
	Nimocast 80	-	-	69.9	20	2	5	-	0.1	-	-	1	2	-
	Nimocast 90	-	-	52.9	20	18	5	-	0.1	-	-	1.5	2.5	-
	Nimonic 80A	-	350	75	19.5	-	-	-	0.08	-	-	1.4	2.4	-
	Nimonic 90	-	346	59	19.5	16.5	-	-	0.08	-	-	1.5	2.5	-
	Nimonic 105	-	320	53	15	20	-	5	0.12	-	-	4.7	1.2	-
	Nimonic 115	-	350	59	14.2	13.2	-	4	0.16	-	-	5	4	-
	Nimonic 901	-	350	44	12.5	-	35	5.7	0.04	-	-	0.3	2.9	-
	Nimonic 263/C263	-	275	51.5	20.2	20	-	6	0.06	-	-	0.5	2	-
	Nimonic PE16	-	250	43.5	16.5	-	34	3.3	0.06	-	-	1.2	1.2	-
	Nimonic PK33	-	350	55.9	18	14	0.5	7	0.05	0.25	0.25	2.1	2.2	-
	R-235	-	-	63.3	15	1.2	10	5.5	0.12	0.1	0.3	2	2.5	-
Rene 41	-	-	53.1	19	11	1.8	10.5	0.09	0.3	0.3	1.5	3.1	-	
Udimet 500	-	-	51.7	19	19	-	4	0.4	0.1	0.1	3	3	-	
Udimet 718	180	380	52.5	18	-	18	3	0.05	-	-	0.6	0.1	5.2	
Waspaloy	-	HRC35-42	56.9	19.8	13.5	0.8	4.45	0.07	0.1	0.1	1.4	3	-	
Cast or Cast and Aged	GMR 235	-	-	63.3	15.5	-	10	5.2	0.15	0.25	0.6	3	2	0.06
	GMR 235D	-	-	63	15.5	-	4.5	5	0.15	0.1	0.3	3.5	2.5	0.05
	IN-100	-	-	61.6	10	15	-	3	0.18	1.2	0.5	5.5	4.75	-
	Jessop G39	130	-	67.5	19.5	-	5	3	0.5	-	-	-	-	4.5
	Jessop G64	220	-	60.7	11	-	2	3	0.15	-	-	6	-	4
	Jessop G81	-	300	79.3	20	13	-	-	0.05	-	-	1.3	2.3	-
	MAR-M200	-	-	69.4	9	10	-	-	0.15	-	-	5	2	13.5

USA		UK	France	Germany		Others
SAE	AMS	BS	AFNOR	Werkst.-Nr	DIN1706	
-	-	-	-	-	-	-
-	-	-	-	-	-	-
-	-	-	-	-	-	-
-	5660	-	ZSSNCDT42	LW2.4662	NiFe35Cr14MoTi	N09901
-	-	-	-	-	-	-
-	-	-	-	-	-	-
-	-	-	-	-	-	-
-	-	-	NK27CADT	-	NiCo29Cr15MoAlTi	-
-	5550	-	-	-	-	N07702
-	5702	-	-	-	-	N09707
-	5391	Mar-46	NC12AD	LW2.4670	S-NiCr13Al6MoNb	-
5383	5589	HR8	NC19FeNB	LW2.4668	NiCr19Fe19NbMo	N07713
-	5596G	-	-	-	-	-
-	5541	-	NC16FeTi	-	NiCr16FeTi	N07722
5542G	5582	-	NC16FeTNb	2.4669	NiCr16FeTi	N07750
-	-	-	-	-	-	N07751
-	-	-	-	-	-	-
-	5551	-	-	2.4916	S-NiCr19Co	N07252
-	-	-	-	2.4675	NiCo10W10Cr9AlTi	-
-	-	-	-	-	NiCr16Co10WAlTi	-
-	-	-	-	-	NiCo20Cr16WAlTi	-
4676	-	3072-76	-	2.4375	NiCu30Al	N05500
-	-	3146	-	-	-	-
-	-	-	-	-	-	-
-	-	HR401,601	NC20TA	2.4631	NiCr20TiAl	N07080
-	-	HR2,202	NC20TAV	2.4632	NiCr20Co18Ti	N07090
-	-	HR3	NCKD20ATV	2.4634	NiCo20Cr15MoAlTi	-
-	-	HR4	NCK15ATD	2.4636	NiCo15Cr15MoAlTi	-
5660C	5661A	-	ZSNCDT42	2.4662	NiCr15MoTi	-
-	-	HR10	NCK20D	2.465	NiCr15Co19MoTi	-
-	-	HR207	NW11AC	-	NiFe33Cr17Mo	-
-	-	-	NC19KDUV	-	NiCr20Co16MoTi	-
-	-	-	-	-	-	-
-	5399	-	NC19KDT	2.4973	NiCr19Co11MoTi	N07041
-	5751	-	NCK19DAT	2.4983	NiCr18Co11MoTi	N07500
5383	5589	HR8	NC19FeN	LW2.4668	NiCr19Co19NbMo	N07718
-	5544	-	NC20K14	LW2.4668	NiCr19Co19NbMo	N07001
-	-	-	-	-	-	AlSi:686
-	-	-	-	-	NiCr16MoAl	-
-	5397	-	-	LW2.4674	NiCo15Cr10MoAlTi	N13100
-	-	-	-	-	NiCr20MoW	-
-	-	-	-	-	NiCr11AlWNb	-
-	-	-	-	-	NiCr20Co18Ti	-
-	-	-	-	-	NW13Co10Cr9AlTi	-

TECHNICAL DATA

COMPARISON OF WORK-PIECE (NI-BASED HEAT RESISTANT ALLOYS)

Material Condition	Commercial designation	Hardness Brinell HB		Nominal composition Approximate content in %										
		Ann.	Aged	Ni	Cr	Co	Fe	Mo	C	Mn	Si	Al	Ti	Others
Co-based Alloys	Air Resist 13	-	-	1	-	79.6	2.5	-	11	-	-	3.5	-	4.12
	Air Resist 213	-	-	-	19	65.8	-	-	4.7	-	-	3.5	-	6.68
	Altemp S 816	-	-	20	20	47.6	-	4	4	-	-	-	-	0.4
	STELLITE 6	-	-	-	26	72	-	-	5	-	-	-	-	-
	FSX 414	-	-	10	29	52.8	1	-	7	-	-	-	-	0.25
	Haynes 36	-	-	10	18.5	52.8	2	-	14.5	1.2	0.6	-	-	0.4
	Haynes 151	-	-	-	20	65.6	-	-	12.8	0.5	0.5	-	0.15	0.47
	HS 25	-	-	10	20	48.4	3	-	15	1.5	2	-	-	0.1
	HS 30	-	-	16	24	51.4	1	6	-	0.6	0.6	-	-	0.4
	HS 31	-	-	10	25	53.8	1.5	-	8	0.6	0.8	-	-	0.4
	HS 36	-	-	10	18	53.1	2	-	15	1.5	-	-	-	0.4
	Inconel 783	-	-	28.5	3	34	26	-	-	-	-	5.4	0.1	3
	Jessop 832	-	-	12	19	44	17	2	-	0.8	0.3	-	-	3.5
	Jessop 834	-	-	12	19	42	20	2	-	-	-	-	-	6.5
	Jessop 865	-	-	10.5	25.5	53	2	-	7.5	0.6	0.6	-	-	0.45
	Jessop 875	-	-	-	21	66	-	-	11	-	-	-	-	2.45
	Jessop 887	-	-	10	20	50	3	-	15	0.5	1.5	-	-	0.1
	Jetalloy 209	-	-	10	20	52	1	-	15	-	-	-	2	0.02
	L-251	-	-	10	19	56	1	-	14	-	-	-	-	0.4
	L-605	-	-	10	20	51	1.6	-	15	1.5	0.6	-	-	0.1
	M 203	-	-	25	20	38	1.6	-	12	0.8	1	0.7	2	1.67
	M 204	-	-	25	18	42	1.6	-	12	-	-	-	-	1.27
	M 205	-	-	25	18	40	1.6	-	12	-	-	2.7	-	1.67
	ME16	-	-	-	15	23	2	5	-	-	-	5	-	22.25
	MP35N	-	-	37	21	29.2	1	10.5	-	0.15	0.15	-	1	0.04
	NF3	-	-	-	14.3	22.4	-	3.9	-	-	-	4.8	4.6	17.9
	MAR-M 302	-	-	-	21.5	57	0.75	-	10	0.1	0.2	-	-	10
	MAR-M 322	-	-	-	21.5	60	0.75	-	9	0.1	0.1	-	0.75	7.7
	MAR-M 509	-	-	10	23	55	-	-	7	0.05	0.05	-	0.2	4.6
	MAR-M 905	-	-	20	20	55	-	-	-	-	-	-	0.5	7.65
	MAR-M 918	-	-	20	20	52	0.4	-	-	0.1	0.1	-	0.5	7.65
	Refractalloy 70	-	-	20	21	46	0.5	8	4	-	-	-	-	0.08
Udimet 188	-	-	22	22	38	3	-	14	1.25	-	-	-	-	
V-36	-	-	20	25	43.2	2.4	4	2	0.6	0.5	-	-	2.29	
WI-52	-	-	0.5	21	62.6	2	-	11	0.25	0.25	-	-	2.45	
Jessop X-40	-	-	10.5	25.5	53	1.5	-	7.5	0.75	0.75	-	-	0.5	
Jessop X-45	-	-	10.5	25.5	54.7	2	-	7	-	-	-	-	0.25	
Jessop X-50	-	-	20.5	25.5	40.3	4	-	12	-	-	-	-	0.75	
Jessop X-63	-	-	10	25	57.6	1	6	-	-	-	-	-	0.45	
Annealed or Solution Treated	J 1650	-	-	27	19	38	-	-	12	-	-	-	0.2	
In Aged Condition	Haynes 25	-	-	10	20	49	3	-	15	0.5	0.5	-	0.1	
	Haynes 188	-	-	22	22	38	2.5	-	14	0.4	0.4	-	0.1	
	HS 6	-	-	2.5	28	60.5	3	-	5	-	-	-	1	
	HS 21	-	-	3	27	62.6	2	5	-	0.6	0.6	-	0.25	
	J 1570	-	-	28	19	39	2	-	7	-	-	-	-	

USA		UK	France	Germany		Others
SAE	AMS	BS	AFNOR	Werkst.-Nr	DIN 1706	
-	-	-	-	-	-	-
-	-	-	-	-	-	-
-	(5534)	-	-	LW2.4989	CoCr20Ni20W	-
-	-	-	-	-	-	-
-	-	-	-	-	-	-
-	-	-	-	-	CoCr19W14NiB	-
-	-	-	-	-	CoCr20W13	-
-	5759	-	KC20WN	LW2.4964	CoCr20W15Ni	-
5380	-	-	-	-	CoCr25NiW	R30030
5382	-	3146	-	LW2.4670	CoCr25NiW	R30031
-	-	-	-	-	CoCr19W14NiB	-
-	5940	-	-	-	-	-
-	-	-	-	-	CoCr19Fe16NiMoVNB	-
-	-	-	-	-	CoCr19Fe20NiMoVNB	-
-	-	-	-	-	CoCr25NiW	-
-	-	-	-	-	CoCr21W11Nb	-
-	-	-	-	-	CoCr20W15Ni	-
-	-	-	-	-	-	-
-	5759	-	-	2.4964	CoCr20W15Ni	R30605
-	-	-	-	-	-	-
-	-	-	-	-	-	-
-	-	-	-	-	-	-
-	-	-	-	-	-	-
-	5844	-	-	-	-	-
-	-	-	-	-	-	-
-	-	-	-	-	CoCrW10TaZrB	-
-	-	-	-	-	CoCr22W9TaZrNb	-
-	-	Mar-46	-	-	CoCr24Ni10W1TaZrB	-
-	-	-	-	-	-	-
-	-	-	-	-	CoCr20Ni20Ta	-
-	-	-	-	-	-	-
-	-	-	-	-	-	-
-	-	-	-	-	CoCr25NiMoWNB	-
-	-	-	-	-	CoCr12MoW	-
-	5382	3156-2	-	LW2.4670	CoCr25NiW	-
-	-	-	-	-	-	-
-	-	-	-	-	-	-
-	-	-	-	-	-	-
-	-	-	-	-	-	-
5537C	5759	-	KC20WN	LW2.4954	CoCr20W15Ni	-
-	5772	-	KC22WN	-	CoCr22W14Ni	-
-	5373	-	-	-	-	R30006
-	5385	3531	-	-	CoCr29Mo	R30021
-	-	-	-	-	-	-

INDEX

A/B

ARE01	MILLING & DRILLING	266
ARE02	MILLING & DRILLING	266
BSN	CERMET	102
BTN	CERMET	102

C

CCBN	TOOL HOLDER	145
CCGW	CERAMIC	30
CCGW	PCBN	110
CCGW	PCD	114
CCGX	CERAMIC	29
CCKN	TOOL HOLDER	146
CCLN	TOOL HOLDER	144
CCMT	CERMET	91
CDH	CERAMIC	52
CDHN	TOOL HOLDER	147
CDJN	TOOL HOLDER	148
CDNN	TOOL HOLDER	149
CEFN	TOOL HOLDER	150
CEGN	TOOL HOLDER	151
CEJN	TOOL HOLDER	152
CFLN	TOOL HOLDER	182
CGVN	TOOL HOLDER	184
CINN	TOOL HOLDER	185
CLKN	TOOL HOLDER	181
CNGA	CERAMIC	24
CNGA	PCBN	110
CNGA	PCBN	114
CNGA	PCD	120
CNGN ..AZ	CERAMIC	74
CNGN	CERAMIC	26
CNGN	PCBN	118
CNGX	CERAMIC	28
CNMA	CERAMIC	25
CNMG	CERMET	86
CNMN	CERAMIC	27
CNMX ..RD	CERAMIC	29
CNMX	CERAMIC	29
CNVX	CERAMIC	28
CPGN	CERAMIC	31
CPGT	CERMET	91
CPGW	PCD	120
CRDB	TOOL HOLDER	155
CRDC	TOOL HOLDER	156
CRDN	TOOL HOLDER	153
CRGN	TOOL HOLDER	154
CSBF	TOOL HOLDER	173
CSBN	TOOL HOLDER	157
CSBR	TOOL HOLDER	174

CSC	MILLING CUTTER	234
CSDN	TOOL HOLDER	158
CSGF	TOOL HOLDER	175
CSGR	TOOL HOLDER	176
CSKN	TOOL HOLDER	159
CSRC	TOOL HOLDER	166
CSRN	TOOL HOLDER	160
CSSC	TOOL HOLDER	167
CSSF	TOOL HOLDER	177
CSSN	TOOL HOLDER	161
CSSR ..N	TOOL HOLDER	179
CSSR	TOOL HOLDER	178
CSTP	TOOL HOLDER	168
CSVN	TOOL HOLDER	183
CSYN	TOOL HOLDER	162
CTFN	TOOL HOLDER	163
CTFP	TOOL HOLDER	169
CTGN	TOOL HOLDER	164
CVJN	TOOL HOLDER	171
CVVN	TOOL HOLDER	172
CWF/R	TOOL HOLDER	180
CWLN	TOOL HOLDER	165

D

DCGW	CERMET	91
DCGW	PCBN	114
DCGW	PCBN	110
DCGW	PCD	121
DCGX	CERAMIC	34
DNGA	CERAMIC	32
DNGA	PCBN	115
DNGA	PCBN	110
DNGA	PCD	120
DNGG	CERMET	94
DNGN	CERAMIC	33
DNGX	CERAMIC	34
DNMA	CERAMIC	32
DNMG	CERMET	87
DNMX	CERAMIC	34

E/F

ENGN	CERAMIC	35
FBC	MILLING & DRILLING	270
F-Series	CERAMIC	53
F-Series	CERAMIC	53
F-Series	CERAMIC	54
F-Series	CERAMIC	54

G/H

GVGN	CERAMIC	77
HFC01	MILLING & DRILLING	268

HFC01	MILLING & DRILLING	268
HNEN	CERAMIC	66
HPA - H	MILLING CUTTER	238
HPA - I	MILLING CUTTER	237
HPA - M	MILLING CUTTER	239
HRC01	TOOL HOLDER	170

I/J

INGN	CERAMIC	80
INGN	CERMET	103
JSFD 2xD	MILLING & DRILLING	275
JSFD 3xD	MILLING & DRILLING	276
JSFD 4xD	MILLING & DRILLING	277
JTR 2xD	MILLING & DRILLING	272
JTR 3xD	MILLING & DRILLING	273
JTR 4xD	MILLING & DRILLING	274

L/O/Q

LNE	CERAMIC	66
LNJ	CERAMIC	55
OEGB	CERAMIC	67
OMR07	MILLING & DRILLING	271
OPEN	CERAMIC	67
QCB - H	MILLING CUTTER	244
QCB - I	MILLING CUTTER	243

R

RBGN	CERAMIC	39
RBGX	CERAMIC	56
RCGN	CERAMIC	39
RCGX	CERAMIC	56
RCGX	PCBN	117
RCGX	PCBN	117
RNGA	PCBN	119
RNGN	CERAMIC	36
RNGN	PCBN	117
RNGN	PCBN	118
RNGX ..DP	CERAMIC	38
RPGA	CERAMIC	37
RPGN	CERAMIC	37
RPGN	PCBN	117
RPGX ..DP	CERAMIC	38
RPGX	CERAMIC	57
RXGX	CERAMIC	57

S

SBAR	CERMET	106
SBE ..1C	PCBN/PCD	134
SBE ..2C	PCBN/PCD	134
SCGN ..MZ	CERAMIC	77
SCGN ..WZ	CERAMIC	76

SCGN ..XZ	CERAMIC	76
SCGN ..ZZ	CERAMIC	76
SCGN	CERAMIC	43
SCGW ..FS	PCBN	113
SCGW	CERAMIC	43
SCGW	PCBN	111
SCGW	PCBN	115
SCGW	PCD	121
SCGX	CERAMIC	43
SDCN ..T	CERAMIC	69
SDCN	CERAMIC	69
SDCN	CERMET	97
SDCW	CERAMIC	69
SDEN	CERMET	97
SDEW	CERMET	98
SDKN	CERMET	97
SEAN ..NW	CERAMIC	70
SEAN ..T	CERAMIC	70
SEAN	CERAMIC	70
SEHW	CERMET	98
SEKN ..R	CERMET	99
SEKN	CERMET	99
SEXP	MILLING CUTTER	232
SFAN ..75	MILLING CUTTER	206
SFAN ..88	MILLING CUTTER	204
SFCN ..00 ..R	MILLING CUTTER	220
SFCP ..00 ..R	MILLING CUTTER	222
SFE ..1C	PCBN/PCD	133
SFE ..2C	PCBN/PCD	133
SFKN ..45	MILLING CUTTER	196
SFKN ..75	MILLING CUTTER	194
SFKN ..88	MILLING CUTTER	192
SFKN ..HX	MILLING CUTTER	214
SFKP ..45	MILLING CUTTER	202
SFKP ..75	MILLING CUTTER	200
SFKP ..88	MILLING CUTTER	198
SFKP ..MF	MILLING CUTTER	216
SFMS ..LRF	MILLING CUTTER	218
SFSP ..OT	MILLING CUTTER	212
SFSX ..00 ..EC	MILLING CUTTER	208
SFSX ..70 ..EC	MILLING CUTTER	210
SFXN	MILLING CUTTER	224
SFXP	MILLING CUTTER	226
SGF	CERAMIC	59
SGR	CERAMIC	59
SNCN ..ENTN	CERAMIC	68
SNCN ..GZ	CERAMIC	75
SNCN ..KZ	CERAMIC	75
SNCN ..ZZT	CERAMIC	75
SNCN	CERAMIC	68
SNGA	CERAMIC	40

INDEX

SNGA	PCBN	114
SNGA	PCBN	111
SNGA	PCD	119
SNGF	CERAMIC	80
SNGG	CERMET	94
SNGL	CERMET	94
SNGN .. ING	CERAMIC	68
SNGN3812R	CERAMIC	55
SNGN	CERAMIC	41
SNGN	PCBN	111
SNGN	PCBN	118
SNGN	PCD	121
SNGX	CERAMIC	42
SNK	CERMET	98
SNMA	CERAMIC	40
SNMG	CERMET	88
SNMX .. RD	CERAMIC	42
SNMX	CERAMIC	42
SNMX	CERAMIC	79
SPCN .. T	CERAMIC	71
SPCW	CERAMIC	71
SPEN	CERAMIC	71
SPGN	CERAMIC	44
SPGN	PCD	122
SPGT	CERMET	92
SPGW	PCD	122
SPHX	CERAMIC	72
SPKN .. SP	CERAMIC	72
SPKN	CERAMIC	72
SPKN	CERMET	99
SPMW	CERMET	93
SSF	CERAMIC	60
SSR	CERAMIC	60
SVW	CERAMIC	78
SYBF	CERAMIC	58
SYBR	CERAMIC	58
SZT 5810	CERAMIC	79
SPIDC	DRILLING	280

T

TBGW	PCD	122
TCGW	PCBN	112
TCGW	PCD	123
TCUN	CERAMIC	47
TEKN	CERAMIC	73
TEKN	CERMET	100
TNCN	CERAMIC	73
TNGA	CERAMIC	45
TNGA	PCBN	119
TNGA	PCBN	115
TNGA	PCD	122

TNGG .. F	CERMET	95
TNGG .. FS	CERMET	95
TNGG	CERMET	95
TNGN	CERAMIC	46
TNGN	PCBN	118
TNMG .. 2G	CERMET	96
TNMG	CERMET	89
TPGB	PCBN	112
TPGB	PCD	123
TPGN	CERAMIC	48
TPGN	PCBN	112
TPGN	PCD	123
TPGR	CERMET	93
TPGT .. KC	CERMET	92
TPGT	CERMET	92
TPGT	PCD	124
TPGW	PCBN	115
TPGW	PCBN	112
TPGW	PCD	124
TPKN	CERAMIC	73
TPKN	CERMET	100
TPUN	CERAMIC	48

V

VBGW	PCBN	116
VBGW	PCBN	113
VBGW	PCD	124
VCGW	PCBN	113
VCGW	PCD	125
VNGA	CERAMIC	49
VNGA	PCBN	116
VNGA	PCBN	113
VNGA	PCD	124
VNGN	CERAMIC	49
VNGX	CERAMIC	50

W/X/Y

WFC	CERAMIC	61
WFP	CERAMIC	63
WNGA	CERAMIC	51
WNGX	CERAMIC	51
WNMG	CERMET	90
WRC	CERAMIC	62
WRP	CERAMIC	64
WIDC	DRILLING	284
XCET	CERMET	100
YCE	CERMET	100

MEMO